



Following your own rules. The all-new Audi A6.





What makes the all-new A6 so special?

A design for both the head and the heart. A drive that thrills the senses. Pull-away power that takes your breath away. But that's only the beginning. The following pages will tell you more about the extraordinary qualities of the all-new Audi A6. Ultimately one question will remain: When would you like to get on board?

Engines that redefine motion itself.

The engines featured in the all-new Audi A6 have the power to turn simple movement into a whole new feeling of progress. Each unit delivers impressive power to the road – as well as a rich driving experience from the cockpit.

Leading the way is the 4.2 liter V8, developing 335 hp and 311 lb-ft of torque. This powerful but lightweight engine accelerates the A6 quattro® from 0 to 60 mph (100 km/h) in just 6.1 seconds – and powers onward to an electronically governed maximum speed of 130 mph (209 km/h).*

The all-new A6 3.2 quattro performs with no less vigor when fitted with the powerful but economical V6 engine with FSI Direct Injection. With 255 hp, the first ever Audi fuel-straight injection (FSI) engine in North America goes from 0-60 mph (100 km/h) in just 7.1 seconds.

Whichever engine you select, the Audi A6 offers a unique marriage of power and exhilaration.

* Obey all local speed and traffic laws.



The traction to turn bends into straights.

Power should only be employed where it is really needed – a matter taken to heart by quattro all-wheel drive. A mechanical center differential is used to distribute power variably and without delay between the front and rear axles, enabling the vehicle to react optimally to varying road and driving conditions. Legendary quattro thus not only improves traction, but allows a dynamic, sporting driving style.

+

+

quattro

- Optimal power utilization
- Immediate adaptation to driving situation
- Audi dynamic chassis
- Trapezoidal-link rear suspension (individual wheel suspension)

+

+

+

+

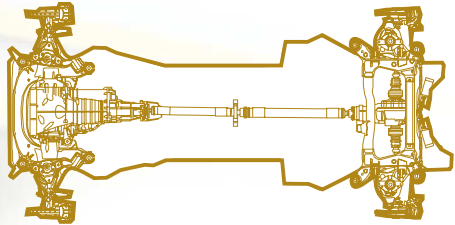

+

+



A complex system made simple. MMI.

The interior of the all-new Audi A6 holds true to the promise of its progressive exterior design. The cockpit is oriented toward the driver, so that one doesn't merely feel at home – one is at home. What's more, all major electronic functions can be controlled centrally and intuitively thanks to MMI™, the Multi Media Interface. Entertainment, navigation and complete vehicle information can be accessed via a single controller. MMI includes an enhanced radio, CD changer and a dash-board mounted 7-inch (178 mm) color display. Optional additions to this system include a DVD-based navigation system and a Bose® premium audio system.

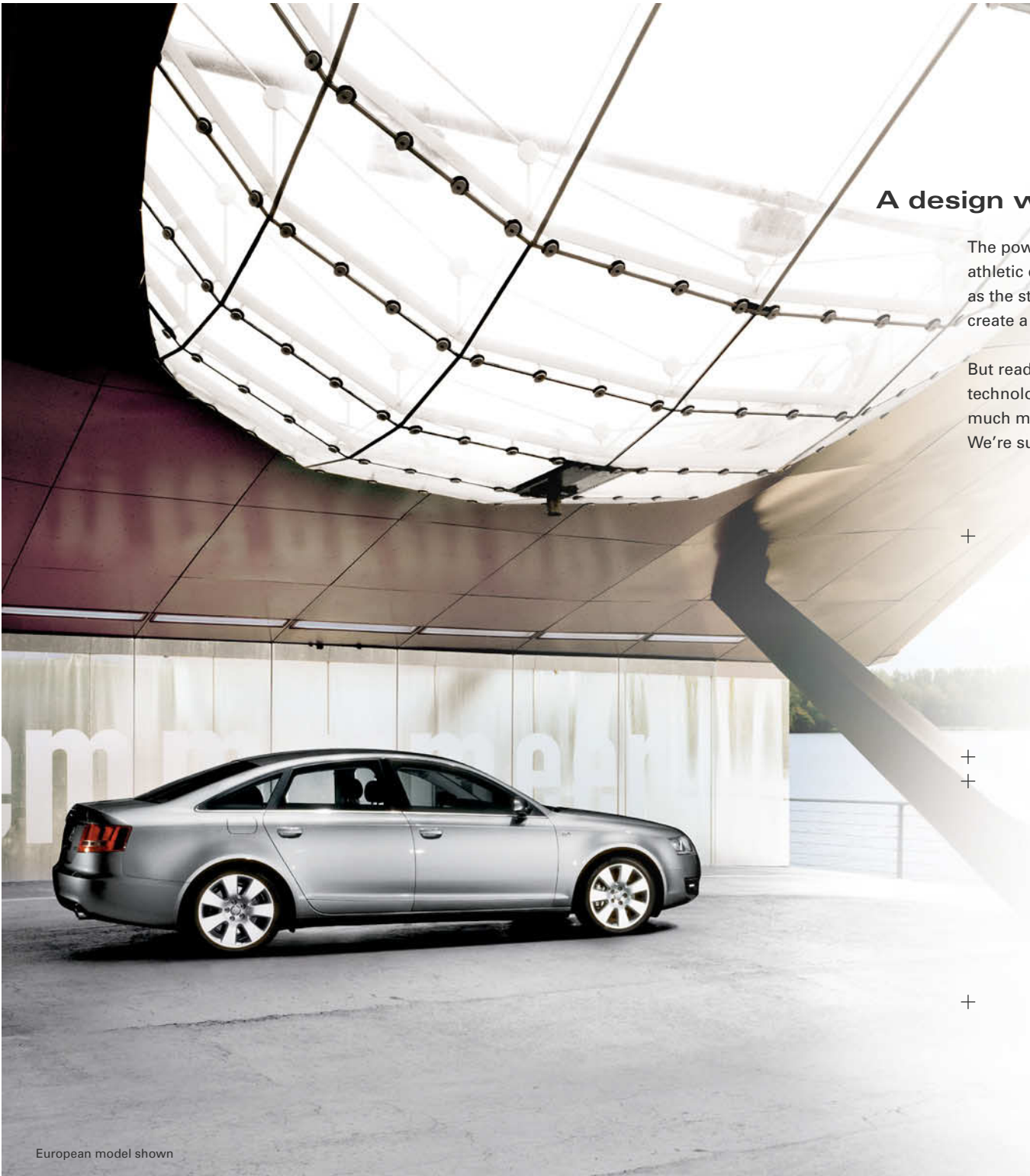

A design whose fascination never fades.

The power of the all-new Audi A6 is given full expression by its athletic design. Taking the evolutionary Singleframe radiator grille as the starting point, elegant lines sweep over the whole car to create a tantalizingly dynamic look.

But reading alone about design, MMI, quattro and engine technology can never do full justice to the all-new Audi A6. There is much more to experience first hand – best of all during a test drive. We're sure you'll enjoy it.

Design

- 1 Singleframe radiator grille
- 2 Dynamic line, roof line, shoulder line
- 3 Additional space, additional comfort
- 4 Accentuated rear (wind contours)

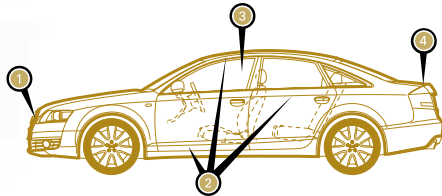

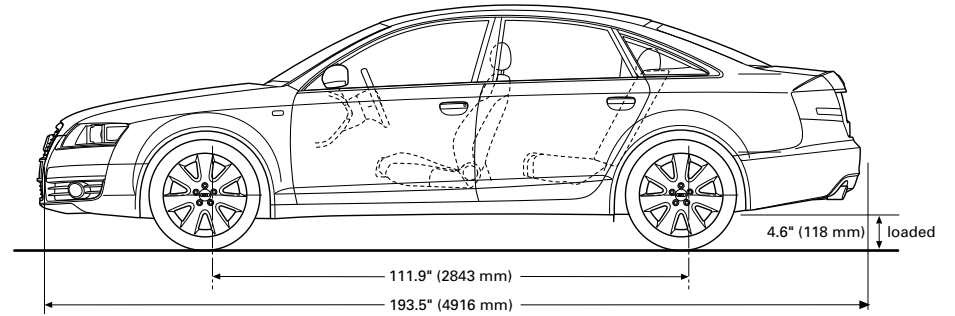
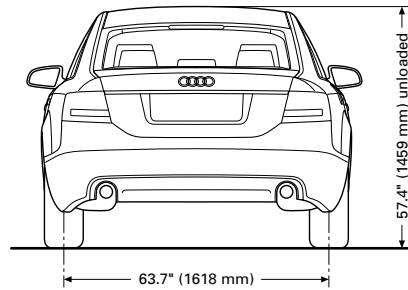
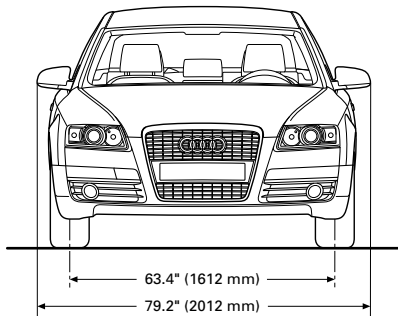

Power and Performance	A6 3.2 quattro	A6 4.2 quattro
MODEL CONFIGURATIONS	255 hp with 6-speed Tiptronic® automatic transmission and quattro® all-wheel drive	335 hp with 6-speed Tiptronic automatic transmission and quattro all-wheel drive
ENGINES	DOHC aluminum 3.1 liter V6 with 4 valves per cylinder, continuously variable intake and exhaust valve timing	DOHC all-aluminum 90-degree 4.2 liter V8 with 5 valves per cylinder, continuously variable intake and exhaust valve timing
HORSEPOWER	255 @ 6300 rpm	335 @ 6200 rpm
TORQUE	244 lb-ft @ 3200 rpm	311 lb-ft @ 3000-4000 rpm
PERFORMANCE	0-60 mph (100 km/h) in seconds: 7.1 Top track speed: 130 mph (209 km/h) ¹ / Fuel economy: na ²	0-60 mph (100 km/h) in seconds: 6.1 Top track speed: 130 mph (209 km/h) ¹ / Fuel economy: na ²

¹Maximum speed electronically limited to 130 mph in the U.S. (209 km/h in Canada.) Obey all speed and traffic laws. ²Not available at time of printing, see your Audi dealer for details.

Note: A word about this publication. Audi of America, Inc. believes the specifications in this publication to be correct at the time of publishing. However, specifications, standard equipment, options and colors are subject to change without notice. Some equipment may be unavailable when your car is built. Please see your dealer for complete details. "Audi," "quattro," "A6" and the four rings emblem are registered trademarks and "MMI" is a trademark of AUDI AG. "Never Follow" is a registered trademark of Audi of America, Inc. "Tiptronic" is a registered trademark of Dr. Ing. h. c. F. Porsche AG. "Bose" is a registered trademark of the Bose Corporation. ©2004 Audi of America, Inc. To find out more about Audi, call 1-800-FOR-AUDI.



We're proud of our past, but what really gets us going is tomorrow.

Founder August Horch's zeal to constantly improve defines Audi to this day. After all, the essence of Never Follow is to continuously ask what if and why not. Why not maximize performance by sharing power with all four wheels? What if you could manage and monitor every function of the car from a single user interface? Why shouldn't the promise of a car's exterior design always be fulfilled the moment one gets behind the wheel? And while all of us at Audi can be proud of our illustrious past, it's the future that drives us to get to work early and stay late.

Never quit. Never do the expected. Never rest on your laurels.

Never think great is good enough. **Never Follow.**