

Polestar 3
—
Electric SUV



Polestar 3

The SUV for the electric age

Premium electric performance has found a new form. A form defined by sculpted surfaces, discreet details, and optimised aerodynamics. A sleeker and more technical SUV, changing the automotive landscape while keeping the environment a priority. This is Polestar 3.



Polestar 3



Progressive by design

The SUV has played the same role for a long time, being synonymous with excess. Polestar 3 recasts this reputation through an all-electric powertrain and climate-responsible material choices. It is time to turn the SUV into a symbol for a circular, sustainable form of performance.



Interior

With subtle details and carefully curated material combinations, the generous interior space of Polestar 3 is a seamless extension of the exterior design. Enhanced by ambient lighting, technical details, and tactile surfaces, the feeling of premium comfort is present for every passenger.

Animal welfare certified

Sustainability by design

When changing the automotive landscape, electrification is a great start. But not enough. For Polestar 3, sustainability begins even before the first drive. Blockchain technology traces all minerals used, and upholstery, such as leather and wool, are animal welfare certified. Recycled materials are included at every opportunity, ensuring the smallest possible footprint and emissions throughout the car's lifecycle.







Exterior

Design is the tool we use to integrate the latest intelligent technology into the exterior design of Polestar 3. This results in sculpted surfaces, discreet details, and optimised aerodynamics to give a sleeker, more technical look.

Headlights

The 1.3 megapixel HD LED headlights combine minimalist aesthetics with intelligent adaptive technology for a signature expression with an optimised view.

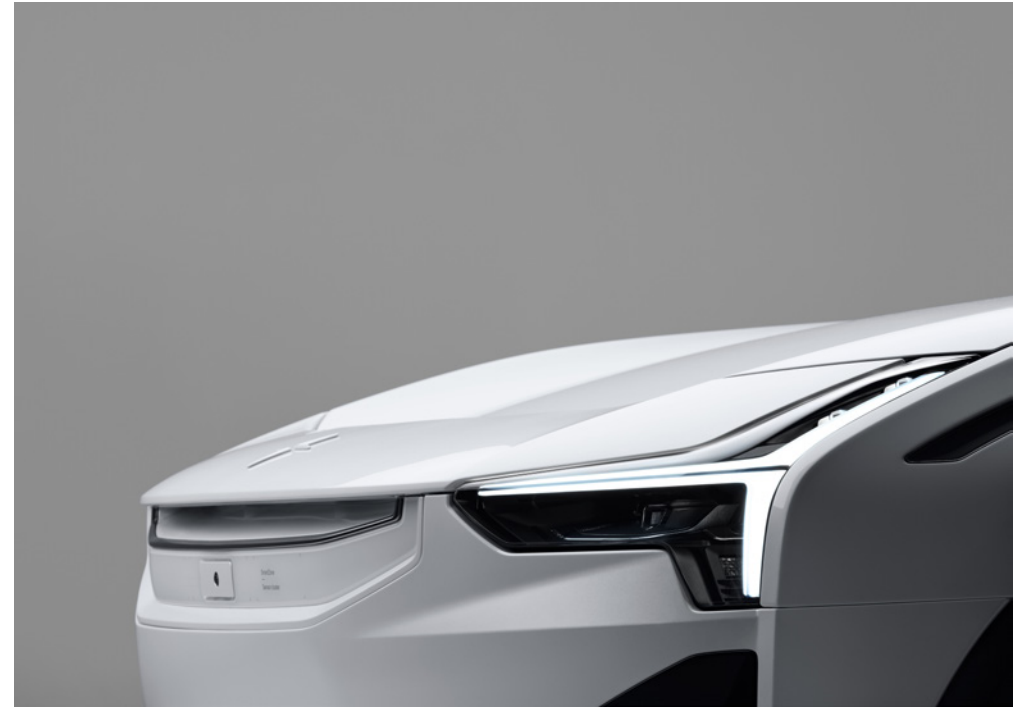

Not available for the US market.



Roofline

By lowering and extending the roofline, Polestar 3 has a distinctive silhouette that maintains a sophisticated presence without compromising on interior space.



Panoramic roof

Made of hi-tech, laminated glass, the panoramic roof reduces 95,5% of UV radiation, lowers cabin noise levels, and adds a spacious feeling.



Snow



Space



Magnesium



Midnight



Thunder



Jupiter

22" 4-Multi spoke black polished forged wheels
Performance pack



22" 4-V Spoke black polished forged wheels
Optional



21" 5-V Spoke black diamond cut wheel
Standard





From breathing to seeing



SmartZone

The frontal area, the SmartZone, integrates all the Advanced Driver Assistance Systems (ADAS) technology. It replaces the grille that functioned as an air intake in internal combustion vehicles. In other words, we go from breathing to seeing. Sensors, radars and cameras inform the driver of changes in the surrounding area.



Performance

A low centre of gravity provides this performance SUV with a perfect 50/50 weight distribution. The all-electric dual motor delivers instant response, with a power of 360kW and torque output of 860 Nm, or 380kW and 910 Nm with the optional Performance pack. Torque vectoring increases turn-in and control, and Brembo brakes are standard for every Polestar 3 for maximum stopping power.

Safety

Polestar 3 shares safety technology with Volvo Cars. Structural innovations protect occupants, while advanced sensory technology prevents collisions, protecting pedestrians and cyclists. The driver is always informed of changing road conditions ahead. Real-time information is shared with other connected Polestar cars.





Polestar 3

Charging speed¹

DC 250 kW, from 10 to 80%

30 min

AC 11 kW, from 0 to 100%

11 hrs

Including
Plus pack
Pilot pack

Long range Dual motor

Enhanced range and a power output of 360 kW.
The launch version of Polestar 3 includes Pilot-
and Plus pack as standard, enabling features for
comfort, safety and an improved driving experience.

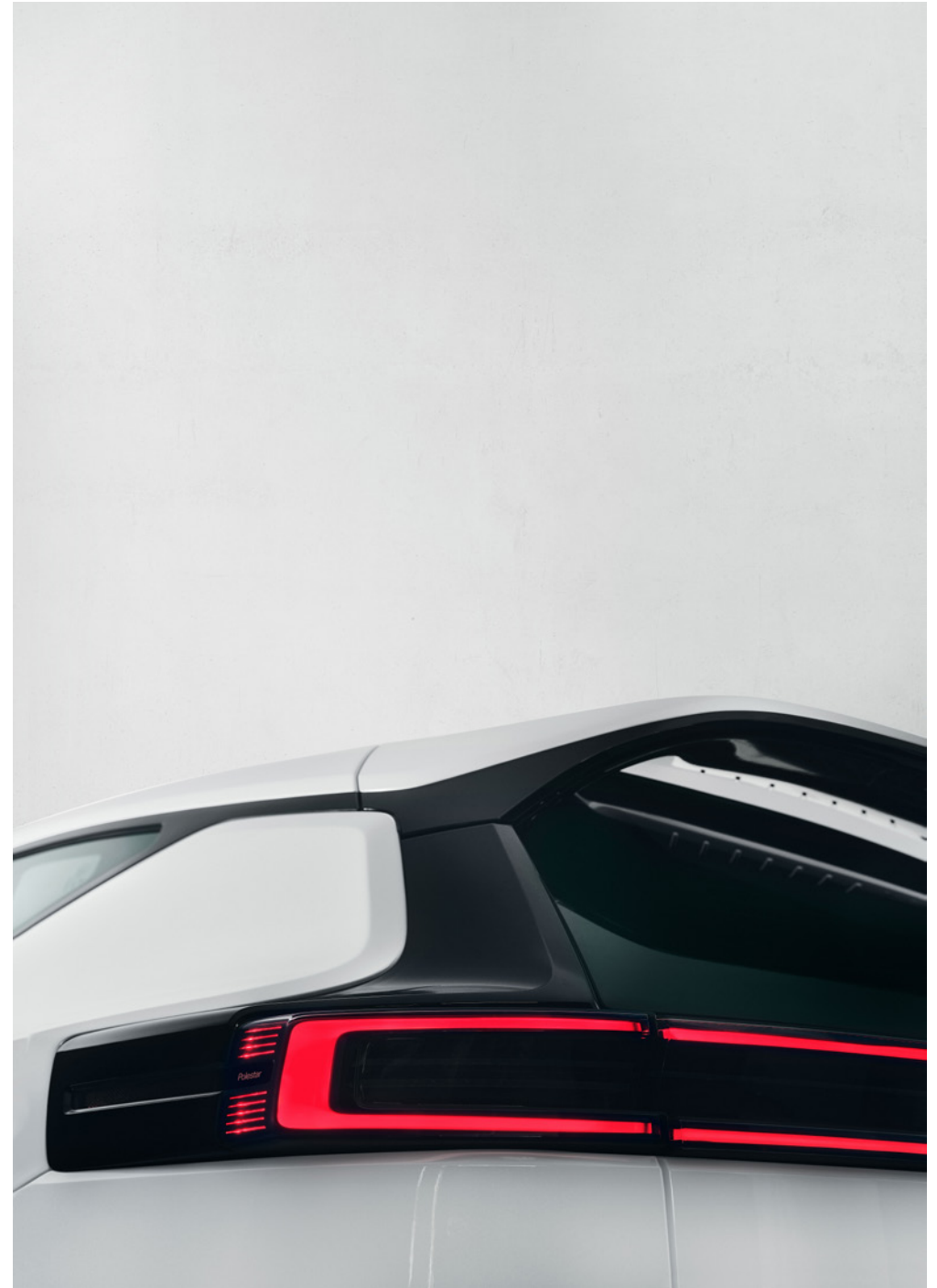

Long range Dual motor

Range up to WLTP¹

610 km
379 mi

Range up to EPA¹

300 mi

Range up to CLTC¹

670 km

Power up to¹

360 kW
489 hp
483 bhp

Torque¹

840 Nm
620 lb-ft

0-100 km/h / 0-62mph¹

5.0 sec

Including

- Performance software upgrade
- Polestar Engineered chassis tuning
- 22" 4-Multi spoke black polished forged wheels
- Laser-etched light line in gold
- Gold valve caps
- Gold seat belts front and rear
- Performance mode on/off

Long range Dual motor with Performance pack

Optimised for responsiveness, this performance version of Polestar 3 offers 380 kW of power. Seatbelts and valve caps are in Swedish Gold, and the 22" 4-Multi spoke black polished forged wheels enhance traction, balance, and handling.



Long range Dual motor with Performance pack

Range up to WLTP¹

560 km

347 mi

Range up to EPA¹

270 mi

Range up to CLTC¹

620 km

Power up to¹

380 kW

517 hp

510 bhp

Torque¹

910 Nm

671 lb-ft

0-100 km/h / 0-62mph¹

4.7 sec

Long range Dual motor
Europe

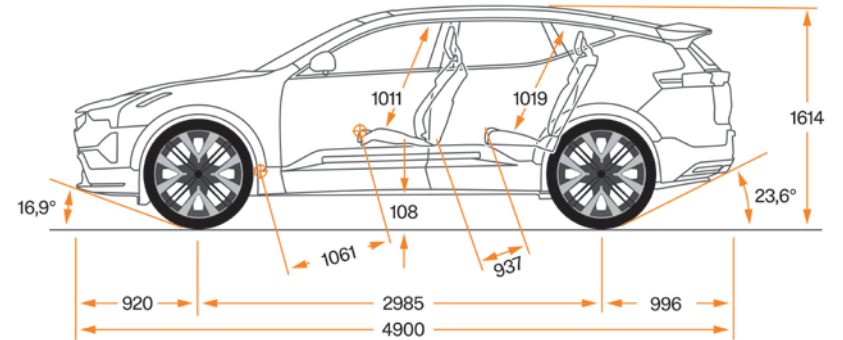

Long range Dual motor
ROW

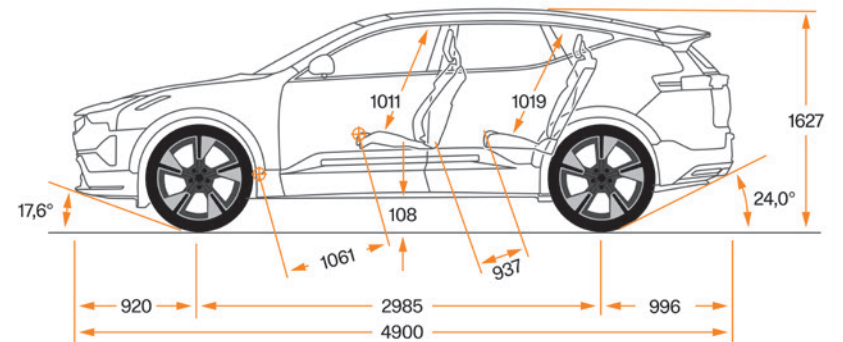

Long range Dual motor
All markets

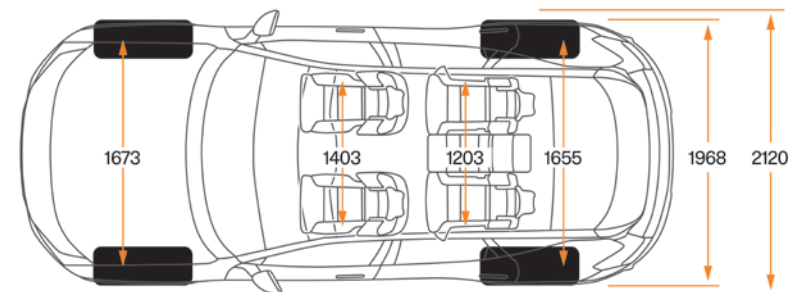

Technical dimensions

Gross weight (kg): 3080 kg
 Curb weight (kg): 2584 kg
 Dimensions (mm): L-4900 mm H-1614 mm W-2120 mm
 Wheelbase (mm): 2985 mm
 Tyre specs: 21" 265/45 295/40 – 22" 265/40 295/35
 Luggage volumes front/rear (liters): 32 L / 484 L

Gross weight (lbs): 6790 lbs
 Curb weight (lbs): 5696 lbs
 Dimensions (inches): L-192.9" H-64.1" W-83.5"
 Wheelbase (inches): 117.5"
 Tyre specs: 21" 265/45 295/40 – 22" 265/40 295/35
 Luggage volumes front/rear (cubic feet): 1.1 cubic feet / 17.1 cubic feet

Polestar

—

Polestar Performance AB
Assar Gabrielssons Väg 9
405 31 Göteborg, Sweden

Connect

polestar.com
info@polestar.com
facebook.com/polestarcars
instagram.com/polestarcars
twitter.com/polestarcars
youtube.com/polestar.com
linkedin.com/company/polestarcars

Visiting address:

Polestar HQ
Assar Gabrielssons Väg 9
418 78 Göteborg

Copyright

All rights reserved.
No part of this brochure may be
reproduced, distributed or transmitted in
any manner without the expressed written
consent of Polestar Performance AB.

© 2022 Polestar Performance AB

The Polestar trademarks are owned
by Polestar Holding AB. Other product
names, trademarks and company names
are property of their respective owners.

¹Preliminary figures. Subject to final certification.