



VOLVO V90

CROSS COUNTRY



YOUR OWN V90 CROSS COUNTRY IS WITHIN REACH

We created the new Volvo V90 Cross Country for a world that demands versatility, without compromising elegance and sophistication. From the exterior's clean, taut lines to the spacious, light-filled cabin, this is an estate car that combines powerful good looks with everyday practicality.

The V90 Cross Country is packed with innovative technology that has one purpose: to make your life easier, and one principle: it must be easy to use. A big touch screen means we have been able to reduce the number of buttons to a minimum, as it is in portrait format reading scrolling maps is much easier. Run-off road Mitigation is world-first innovation that helps to steer you back on track if the car starts to veer off the road accidentally. This is our human-centric approach to technology – it works for you.

V90 CROSS COUNTRY MOMENTUM

The Momentum variant offers a range of smart features like full-LED headlights with Active High Beam, an electric driver's seat with memory and electric lumbar support, a fully-digital 12.3-inch instrument cluster, our portrait-oriented Sensus Connect touch screen interface, rear parking sensors and satellite navigation. Bluetooth®, USB, aux and Internet functionality are fitted as standard as well.

Variants:	Diesel	Petrol
	D4 Geartronic AWD	T5 Geartronic AWD
	D5 Geartronic AWD	T6 Geartronic AWD

V90 CROSS COUNTRY INSCRIPTION

The Inscription version is the ultimate upgrade. Offering higher specification than the Momentum variant, the V90 Cross Country Inscription includes an electric passenger seat with memory, electrically-adjustable seat cushions, fine Nappa leather and illuminated door sills. More poised and stately, the Inscription model is the personification of style and comfort.

Variants:	Diesel	Petrol
	D4 Geartronic AWD	T5 Geartronic AWD
	D5 Geartronic AWD	T6 Geartronic AWD



THE RIGHT EQUIPMENT. It is essential that your Volvo comes equipped with everything you need. Below you will find standard equipment for each model variant, plus optional equipment to personalise your Volvo V90 Cross Country. And as you would expect, there is an array of industry-leading, cutting edge safety innovations.

STANDARD EQUIPMENT – SAFETY AND SECURITY	Momentum	Inscription
City Safety (includes pedestrian, cyclist and large animal detection and front collision warning with full auto brake)	•	•
Road edge detection	•	•
Run-off road protection	•	•
(ACC) Adaptive Cruise Control	•	•
Distance alert	•	•
(DAC) Driver Alert Control with (LKA) Lane Keeping Aid	•	•
(RSI) Road Sign Information display	•	•
(IDIS) Intelligent Driver Information System	•	•
Collision Mitigation Support, front	•	•
Emergency Brake Assist	•	•
Pilot assist II - semi autonomous driving technology	•	•
Personal settings, power steering	•	•
Seatbelt reminders, all seats	•	•
Pyrotechnical pre-tensioners (all seats)	•	•
Drive mode settings	•	•
Dual stage driver and passenger airbags	•	•
Passenger airbag cut-off switch	•	•
(SIPS) Side Impact Protection System	•	•
SIPS airbags (front seats)	•	•
Inflatable curtains - full length	•	•
Whiplash protection system (front seats)	•	•
Vehicle deceleration control (includes anti-lock brake system, electronic brake force distribution and emergency brake assist)	•	•
Stability and traction control (includes spin control, engine drag control and corner traction control)	•	•
ISOFIX attachments (outer rear seats)	•	•
Hill start assist	•	•
Anti-theft alarm including immobiliser, volume sensor and level sensor	•	•
Integrated remote control central locking and auto open/close power windows and sunroof	•	•
Key remote control	•	•
Two step door unlocking	•	•
Private locking for luggage area	•	•
Power child locks (rear doors)	•	•
Central lock switch with diode in front doors	•	•
Visible VIN plate	•	•
Automatic headlight levelling system	•	•
Home safe and approach lighting	•	•
LED daytime running lights	•	•
Warning triangle	•	•
Laminated side windows	•	•
Load cover, manual	•	•
Hill descent control	•	•

STANDARD EQUIPMENT - EXTERIOR	Momentum	Inscription
Black wheel arches	•	•
Bright integrated roof rails	•	•
Wet wiper arms, not heated	•	•
Grille, Cross Country mesh	•	•
Standard mesh front	•	•
High gloss black décor side windows	•	•
Matt black sills and bumpers, lower section	•	•
Dual integrated tail pipes	•	•
Colour coordinated side mirror covers	•	•
Retractable side mirrors	•	•
Colour coordinated door handles	•	•
LED active bending headlights with active high beam	•	•
Headlight cleaning system	•	•
Fog lights in front spoiler	•	•
Adaptive brake lights including high level LED brake light and hazard warning	•	•
Rear park assist	•	•
Cargo opening scuff plate, metal	•	•
19" 6-double-spoke tech matt black diamond cut wheels	•	•
Chassis, touring	•	•
Tempa spare wheel and jack kit	•	•

STANDARD EQUIPMENT - INTERIOR	Momentum	Inscription
Leather upholstery	•	
Nappa soft leather upholstery		•
Comfort seat padding	•	•
Black walnut décor inlays	•	•
12,3 Inch digital instrument cluster	•	•
Power driver seat with memory for seat and side mirrors	•	•
Mechanical passenger seat with power height adjustment	•	
Power adjustable passenger seat with memory		•
Power adjustable side support		•
4-way power adjustable lumbar support	•	•
Power cushion extension, driver and passenger seat		•
Fixed rear headrests	•	•
CleanZone (air quality system)	•	•

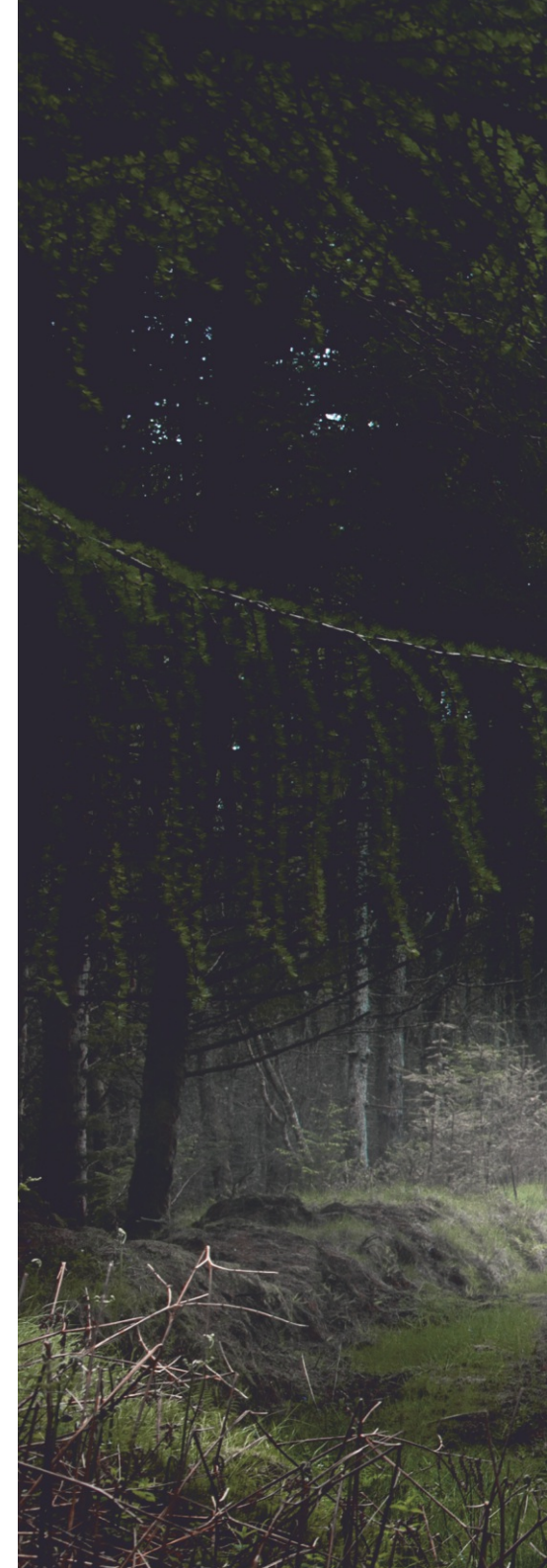



STANDARD EQUIPMENT – INTERIOR Continued

	Momentum	Inscription
Versatile split folding rear seat (60/40)	•	•
Ski hatch in rear seat backrest	•	•
Front and rear armrests with storage and cup holders	•	•
Standard headliner colour	•	•
Interior illumination - mid level	•	
Interior illumination - high level		•
Illuminated vanity mirrors in sunvisor LH / RH side	•	•
3-Spoke leather steering wheel with décor inlay	•	•
Leather gear lever knob with chrome décor inlay	•	•
Standard pedals	•	•
Cigarette lighter / ashtray front + ashtray in rear doors	•	•
Auto dimming interior mirror	•	•
Floor carpets	•	•
Sill moulding Volvo metal	•	
Sill moulding Volvo metal, illuminated		•
Drive modes and power steering settings	•	•
Lockable glove box compartment with illumination	•	•
Rain sensor	•	•
Front and rear power windows – fully automatic	•	•
Luggage compartment illumination	•	•
Net pocket on tunnel console	•	•
Cargo divider	•	•
2-zone electronic climate control	•	•
12V socket in luggage area	•	•
High performance audio system (1 x AUX and 1 x USB) with Bluetooth® connection	•	•
Remote control buttons on steering wheel	•	•
Navigation - Pro (map region for Africa)	•	•
Speech function	•	•

*** OPTIONAL EQUIPMENT – SAFETY AND SECURITY**

	Price incl. 14% VAT	Momentum	Inscription
Keyless Drive (includes keyless entry and keyless start) and handsfree tailgate opening	R7,250.00	o	o
Head Up Display (graphical)	R14,500.00	o	o
(BLIS) Blind Spot Information System with (CTA) Cross Traffic Alert plus collision warning and mitigation support, rear	R8,250.00	o	o
Park assist camera - Generation 2	R6,500.00	o	o
Park assist pilot with park assist front and rear	R7,000.00	o	o
Park assist front and rear	R2,850.00	o	o
Visual park assist with front "Fisheye" view (360° camera)	R12,500.00	o	o
Tinted windows, rear side doors and rear window	R4,750.00	o	o

* OPTIONAL EQUIPMENT - INTERIOR	Price incl. 14% VAT	Momentum	Inscription
Nappa soft leather sport contour seats	R17,500.00	o	n/a
Nappa soft leather perforated and ventilated comfort seats	R11,000.00	n/a	o
Iron ore décor inlays	no cost	o	n/a
Metal mesh décor inlays	no cost	n/a	o
Tailored dashboard and door panels	R13,500.00	n/a	o
Black headlining	R3,000.00	o	o
4-zone electronic climate control with cooled glove box	R6,500.00	o	o
Manually adjustable cushion extension, driver and passenger seat	R1,750.00	o	n/a
Power cushion extension driver and passenger seat	R4,750.00	o	●
Sun blinds, rear side door windows	R2,850.00	o	o
Heated windscreen washer nozzles	R800.00	o	o
Heated steering wheel	R2,500.00	o	o
Heated windscreen	R3,650.00	o	o
Heated front seats	R4,500.00	o	o
Heated rear seats	R2,850.00	o	o
Power passenger seat	R6,000.00	o	●
Backrest massage, front seats (i)	R5,500.00	n/a	o
Power folding rear backrest and headrests	R3,950.00	o	o
Dual child booster cushions, rear seats	R2,800.00	o	o
Load cover, automatic	R2,250.00	o	o
Luggage net, backrest	R2,000.00	o	o
Power operated tailgate	R5,500.00	o	o
Grocery bag holder	R800.00	o	o
230V / 150W outlet in lower rear tunnel	R1,200.00	o	o
Black carpet kit (for light interiors)	no cost	o	o
Interior illumination - high level	R3,250.00	o	●
Sport steering wheel with perforated leather and chrome décor inlays	R1,750.00	o	o
Gearshift paddles	R1,850.00	o	o
Compass in rearview mirror	R1,275.00	o	o
Automatically dimmed inner and exterior mirrors	R1,750.00	o	o
Premium Sound by Bowers and Wilkins	R39,500.00	o	o
CD player in centre console	R1,750.00	o	o
Subwoofer	R3,850.00	o	o
Smartphone integration Apple CarPlay and Android Auto (2 x USB connection)	R4,000.00	o	o

* OPTIONAL EQUIPMENT - EXTERIOR	Price incl. 14% VAT	Momentum	Inscription
Metallic paint	R3,850.00	o	o
Panoramic sunroof with power operation	R19,500.00	o	o
19" 5-double-spoke tech matt black diamond cut wheels	no cost	o	o
20" 10-spoke tech grey diamond cut wheels	R12,750.00	o	o
20" 5-double spoke matt black accessory wheel	R17,250.00	o	o
21" 7-open spoke tech matt black accessory wheel	R20,000.00	o	o
Air suspension (with continuously controlled damping - CCD), 2-corner	R17,500.00	o	o
Full colour adapted sills, bumpers and wheel arches	R12,750.00	o	o





Prices are inclusive of 14% VAT

	Momentum	Inscription
V90 CROSS COUNTRY TECHNO PACK	R 36,500.00	R 36,500.00
Heated front seats	o	o
Head Up Display - HUD (graphical)	o	o
Auto dimming inner and outer mirrors	o	o
Blind Spot Information System (BLIS) with Cross Traffic Alert (CTA)	o	o
Rear park assist camera	o	o
Park assist pilot (including park assist front and rear)	o	o
Keyless entry with remote tag	o	o
V90 CROSS COUNTRY PREMIUM PACK	R 65,000.00	R 65,000.00
Heated front seats	o	o
Power operated tailgate	o	o
Visual park assist + front "Fisheye" view (360 degree camera)	o	o
Auto dimming inner and outer mirrors	o	o
Power folding rear backrest and head restraints	o	o
Premium audio by Bowers and Wilkins	o	o
Blind Spot Information System (BLIS) with Cross Traffic Alert (CTA)	o	o
Park assist pilot (including Park assist front and rear)	o	o
Keyless entry with remote tag and handsfree tailgate opening	o	o
V90 CROSS COUNTRY ADVENTURE PACK	R 75,000.00	R 75,000.00
Heated front seats	o	o
Panoramic sunroof	o	o
Power operated tailgate	o	o
Head Up Display - HUD (graphical)	o	o
Visual park assist + front "Fisheye" view (360 degree camera)	o	o
Auto dimming inner and outer mirrors	o	o
Compass in inner rearview mirror	o	o
Power folding rear backrest and head restraints	o	o
Blind Spot Information System (BLIS) with Cross Traffic Alert (CTA)	o	o
Park assist pilot (including park assist front and rear)	o	o
Keyless entry with remote tag and handsfree tailgate opening	o	o
Power outlet 230V in rear tunnel console	o	o
Air suspension with CCD, 2-corner	o	o

● = standard; o = option; n/a = not available * Fitted at factory

(i) Only in combination with perforated and ventilated upholstery.



“Sensus is our way of enabling you to communicate instinctively with your car, and keep you connected with your digital world.”

YOU'RE IN CONTROL, NATURALLY.

SENSUS

Nothing rounds off a drive in your car better than luxuriating in the rich sound of your favourite piece of music. And our two sound systems – Premium Sound by Bowers and Wilkins and High Performance Sound – turn any drive into a momentous experience.

With Sensus Navigation, you can view your route on the centre display with touch screen functionality. And with smartphone integration, you can use the centre display to access your iPhone® or Android phone. And if you would like to connect devices physically, USB-ports are provided as well.

Thanks to Sensus Connect, which is standard, you can stream your favourite tunes from your device to your car via Bluetooth®. You can also use Bluetooth® or WiFi tethering to connect your Volvo V90 Cross Country to the Internet via your device. You can then browse the web and access a variety of internet radio and media apps.



With our new semi-autonomous driving technology Pilot Assist, your Volvo helps make every journey easier and more relaxing. It actively supports you by automatically adjusting the steering to keep the car centred in the lane while keeping your set speed and distance to the vehicle in front of you. Pilot Assist steering support is active from standstill up to 130 km/h, no leading vehicle required.



City Safety can alert you if you're about to collide with the vehicle in front and applies the brakes if necessary. The system is active at all speeds and can help avoid collisions at speed differences up to 60 km/h in relation to the vehicle in front of you. At higher speed differences, City Safety can help mitigate a collision. City Safety also brakes if you should turn into the path of an oncoming car in an intersection, again helping you to avoid or mitigate a collision.



City Safety also watches out for pedestrians and cyclists, even at night. This is particularly important as pedestrians and cyclists are much harder to see than cars in poor light conditions. If there's a pedestrian or bike into your path, City Safety brakes to avoid or mitigate a collision. As a world-first, City Safety also detects large animals such as elk, horses and reindeer.

A part of IntelliSafe Surround, our BLIS™ system now with steer assist, uses radar sensor technology to alert you to vehicles in your blind spot on both sides of your car and to vehicles approaching fast from behind. Cross Traffic Alert watches out for crossing traffic when you're reversing out of tight parking spaces. Alerting you for approaching vehicles as well as for pedestrians and cyclists, this technology is especially helpful in narrow and crowded areas where the side view might be limited.

“Relax and let your Volvo do the hard work for you.”

“Our Drive-E powertrains give you an exhilarating driving experience with smooth, instant response and a reduced environmental impact.”

COMMITTED TO SAFETY.

SUSTAINABLE DRIVING IS EXCITING.

INTELLISAFE

Since the birth of Volvo Cars in 1927, keeping you safe has been part of our DNA. We have pioneered safety advances and invented life-saving technologies, such as the three-point safety belt. We have also equipped all of our cars with safety cages and laminated windscreens since 1944. In 1976, we developed the catalytic converter and the lambda sond, a sensor that monitors exhaust gas, reducing emissions and boosting performance as well as economy.

Today, we are building cars that actively scan the area around you, looking out for the unexpected. Volvo pioneered City Safety, a low-speed collision avoidance technology that

helps prevent collisions at speeds up to 60 km/h. We were the world's first car manufacturer to include this feature as standard equipment in all new models.

We also developed Pedestrian Detection, a system that detects pedestrians and brakes the car when necessary, and we will not stop there.

Tracker Connect provides access to roadside assistance and emergency support at the touch of a button. In the future, our aim is to design cars that will prevent collisions with other road users altogether.

Volvo Cars has introduced three new safety features with the release of the Model year 2018 specification on the V90 Cross Country range aimed at keeping the driver out of trouble.

The new safety features are designed to provide the driver with automatic steering assistance or support – when required – to help avoid potential collisions.

1. City Safety has been updated to include steering support, which engages when automatic braking alone would not help avoid a potential collision. In such circumstances, the car will provide steering assistance to avoid the obstacle ahead. City Safety helps to avoid collisions with vehicles, pedestrians and large animals. Steering support is active between 50-100 km/h.

DRIVE-E

At the heart of every Volvo car we make is our approach to sustainable driving and innovative thinking. We offer a range of technologies that give you greater efficiency and lower running costs.

Our Drive-E powertrains combine the low-fuel consumption and emissions of a four-cylinder engine with the performance of a six or eight cylinder engine. The result is a smooth, powerful drive, with fewer stops at the pumps. We also offer an Interior Air Quality System that checks incoming air for pollutants and

closes the vents when necessary – we call this CleanZone. An active carbon filter helps protect you from harmful gases and unpleasant odors, so you can breathe happy and healthy.

At Volvo Cars, we always strive to make our manufacturing process sustainable. All of the electricity for our factory in Sweden and Belgium comes from clean, hydro-electric or wind power. Environmentally-aware mobility is central to our philosophy of intelligent, thoughtful luxury.

2. Volvo Cars has also added a system called Oncoming Lane Mitigation, which helps drivers to avoid collisions with vehicles in an oncoming lane.

The system works by alerting a driver who has unwittingly wandered out of a driving lane by providing automatic steering assistance, guiding them back into their own lane and out of the path of any oncoming vehicle. This system is active between 60-140 km/h.

3. Volvo Cars' optional Blind Spot Information System, which alerts drivers to the presence of vehicles in their blind spot, has also received an update to include steer assist functionality that helps to avoid potential collisions with vehicles in a blind spot by steering the car back into its own lane and away from danger.

BESPOKE TAILORING FROM VOLVO. The finest fabrics, superb stitching and exacting attention to detail – whichever interior you choose for your Volvo V90 Cross Country, you will be surrounded by luxury. How will you tailor yours?

NB It is not possible to reproduce exact original shades in printed matter.

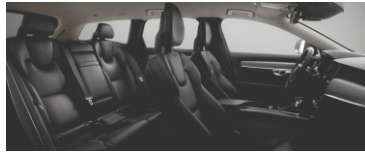

RA00

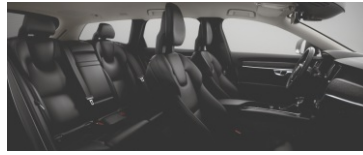

RB00

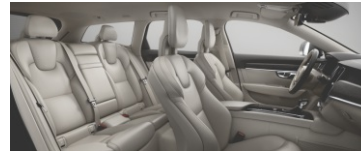

WB00



WB01

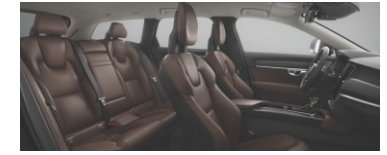

RC30

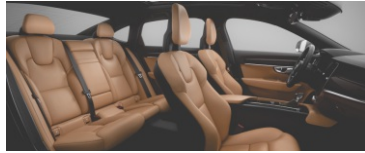

RA20

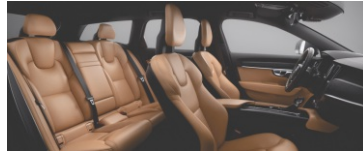

RB20



RB01



RC00



WC00



WA00



RB30



RB21



RC20

Code	Description	Interior colour	Upholstery colour	Upper part of dashboard top	Door panel, lower dashboard, & upper tunnel console	Base and inlay carpets	Door panel inserts	Headliner colour
Standard leather (Momentum only)								
RA00	Charcoal in charcoal	Charcoal	Charcoal	Charcoal	Charcoal	Charcoal	Charcoal	Blond
RA20	Amber in charcoal	Charcoal	Amber	Charcoal	Charcoal	Charcoal	Amber	Charcoal
WA00	Blond in blond	Blond	Blond	Charcoal	Blond	Blond	Blond	Blond
Nappa soft leather								
RB00	Charcoal in charcoal	Charcoal	Charcoal	Charcoal	Charcoal	Charcoal	Charcoal	Blond
RB20	Amber in charcoal	Charcoal	Amber	Charcoal	Charcoal	Charcoal	Amber	Charcoal
RB30	Maroon brown in charcoal	Charcoal	Maroon brown	Charcoal	Charcoal	Charcoal	Maroon brown	Blond
WB00	Blond in blond	Blond	Blond	Charcoal	Blond	Blond	Blond	Blond
Nappa soft leather - sport contour seat (Momentum only)								
RB01	Charcoal in charcoal	Charcoal	Charcoal	Charcoal	Charcoal	Charcoal	Charcoal	Blond
RB21	Amber in charcoal	Charcoal	Amber	Charcoal	Charcoal	Charcoal	Amber	Charcoal
WB01	Blond in blond	Blond	Blond	Charcoal	Blond	Blond	Blond	Blond
Nappa soft leather - perforated and ventilated (Inscription only)								
RC00	Charcoal in charcoal	Charcoal	Charcoal	Charcoal	Charcoal	Charcoal	Charcoal	Blond
RC20	Amber in charcoal	Charcoal	Amber	Charcoal	Charcoal	Charcoal	Amber	Charcoal
RC30	Maroon brown in charcoal	Charcoal	Maroon brown	Charcoal	Charcoal	Charcoal	Maroon brown	Blond
WC00	Blond in blond	Blond	Blond	Charcoal	Blond	Blond	Blond	Blond

INTERIOR DETAILS. A selection of premium materials to complement your interior upholstery.



Leather steering wheel, off black



Dual tone blond/off black steering wheel, leather

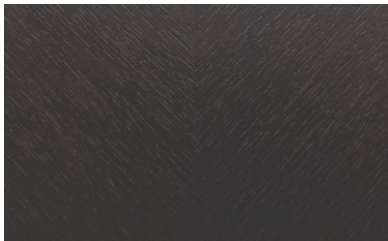

Black walnut décor inlay

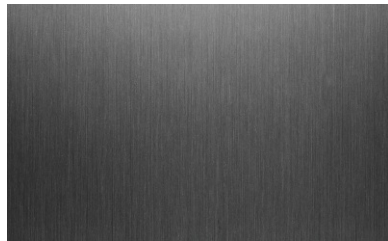

Iron ore décor inlay

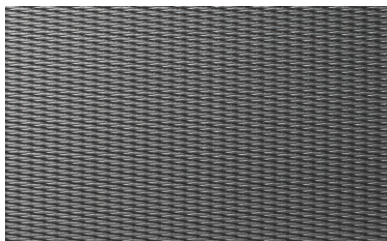

Metal mesh décor inlay

COLOUR YOUR VOLVO. When it comes to the appearance of your Volvo, the choice of exterior colour and wheels are probably your most important design decisions. For more exterior styling options and to build your new Volvo online, please visit www.volvocars.com/za and go to Car Configurator.



019 Black Stone solid



477 Electric Silver metallic



492 Savile Grey metallic



614 Ice White solid



700 Twilight Bronze metallic



707 Crystal White pearl metallic



711 Bright Silver metallic



714 Osmium Grey metallic



717 Onyx Black metallic



719 Luminous Sand metallic



721 Mussel Blue metallic



722 Maple Brown metallic



723 Denim Blue metallic



724 Pine Grey metallic

Please note:

It is not possible to reproduce exact original shades in printed matter. Please ask your dealer to show you samples.

CLEAN COLOURS

To reduce usage of environmentally hazardous solvents all Volvo exterior colours are water-based. What is more, our painting facilities are among the cleanest in the world.

EXTERIOR DESIGN. V90 Cross Country Alloy wheels.

DC: Diamond Cut



19" 6-Double spoke tech matt black, DC



19" 5-Double spoke black, DC



20" 5-Double spoke matt black, DC (accessory wheel)



20" 10-Spoke black, DC



21" 7-Open spoke tech matt black, DC (accessory wheel)





IN FINE DETAIL. The nuts and bolts of your Volvo V90 Cross Country. Whatever you need to know about your new car – be it fuel consumption, CO₂ emissions, top speed or boot space – you will find it here.

ENGINE	V90 Cross Country D4 Geartronic AWD	V90 Cross Country T5 Geartronic AWD	V90 Cross Country D5 Geartronic AWD	V90 Cross Country T6 Geartronic AWD
Configuration	Transverse – 16 valve	Transverse – 16 valve	Transverse – 16 valve	Transverse – 16 valve
Cylinders	4	4	4	4
Engine capacity, cc	1969	1969	1969	1969
Bore x stroke, mm	82 x 93.2	82 x 93.2	82 x 93.2	82 x 93.2
Max. output ECE, kW rpm	140 4250	187 5500	173 4000	235 5700
Max. torque ECE, Nm rpm	400 1750-2500	350 1500-4800	480 1750-2250	400 2200-5400
Octane rating	50ppm Diesel	95 RON unleaded	50ppm Diesel	95 RON unleaded
Fuel system	Twin Turbochargers	HP Turbocharger	Twin Turbochargers	Super & Turbocharged
Compression ratio	15,8:1	10,8:1	15,8:1	10,3:1

PERFORMANCE	V90 Cross Country D4 Geartronic AWD	V90 Cross Country T5 Geartronic AWD	V90 Cross Country D5 Geartronic AWD	V90 Cross Country T6 Geartronic AWD
Top speed, km/h	210	230	230	230
Acceleration 0-100 km/h, sec	8.8	7.4	7.5	6.3

FUEL CONSUMPTION*	V90 Cross Country D4 Geartronic AWD	V90 Cross Country T5 Geartronic AWD	V90 Cross Country D5 Geartronic AWD	V90 Cross Country T6 Geartronic AWD
Combined, ℓ/100 km*	5.2	7.4	5.3	7.7
CO ₂ , g/km*	138	169	139	176
Fuel tank capacity, litres	60	60	60	60

The results do not express or imply any guarantee of the fuel consumption of a particular car as there are inevitable differences between individual cars of the same model. Additionally, driving style, traffic conditions, as well as the age and mileage and standard of maintenance will affect a car's fuel consumption.

- * All fuel consumption figures and CO₂ emissions are based on the New European Driving Cycle (NEDC) test procedure. This test procedure is designed to assess the emission levels of car engines and fuel economy in passenger cars.
- * The results do not express or imply any guarantee of the fuel consumption of a particular car as there are inevitable differences between individual cars of the same model. Additionally, driving style, traffic conditions, as well as the age and mileage and standard of maintenance will affect a car's fuel consumption.
- * The weight of the vehicle will influence the level of CO₂ emitted. As a result, vehicles with higher levels of specification and factory fit options may emit higher levels of CO₂.

TURNING CIRCLE	ALL MODELS
Turning circle, m	11.6

LUGGAGE COMPARTMENT Volume measured in litres	ALL MODELS
Rear seats up, luggage area	560
Rear seats folded	913

TRANSMISSION	ALL MODELS
Geartronic AWD	8 speed

BRAKES	ALL MODELS
Front disc diameter, mm	345 Ventilated
Rear disc diameter, mm	320

GROUND CLEARANCE	ALL MODELS
Vehicle ground clearance, mm	210

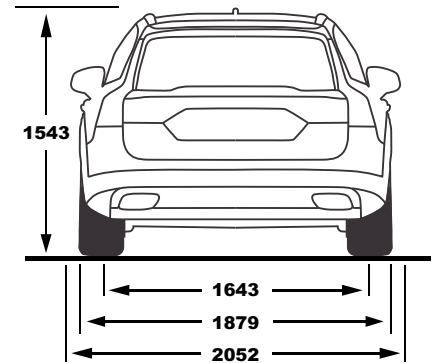
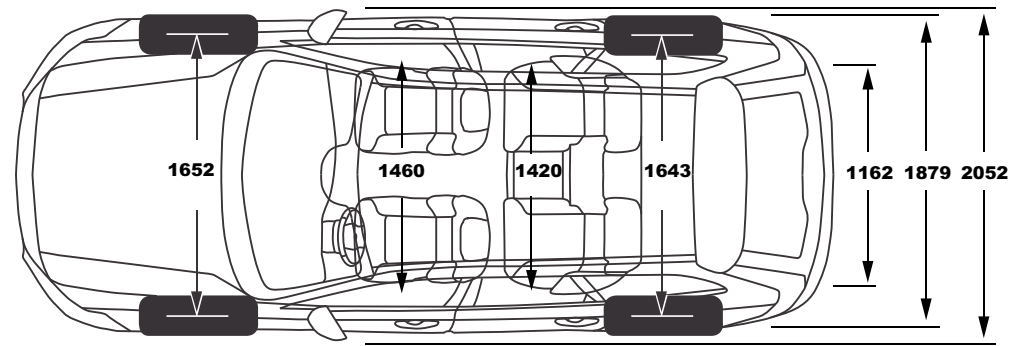
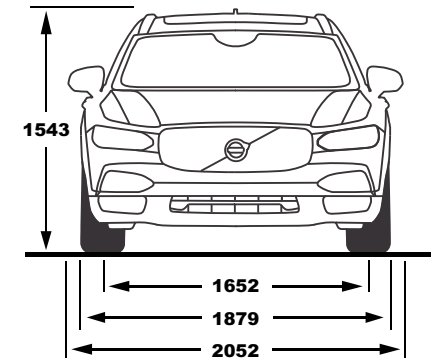
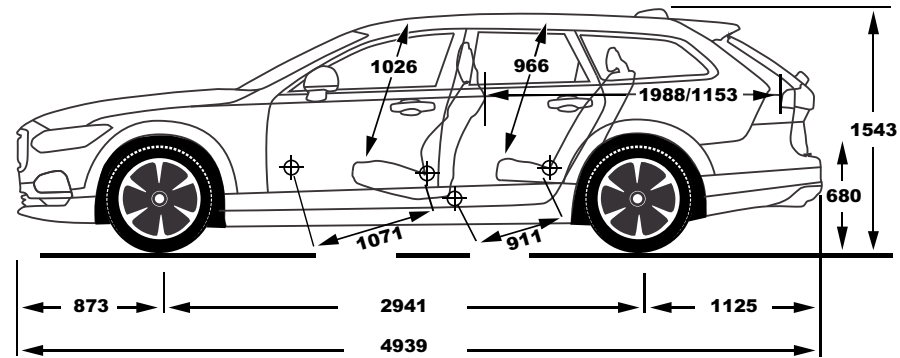

WEIGHT	V90 Cross Country D4 Geartronic AWD	V90 Cross Country T5 Geartronic AWD	V90 Cross Country D5 Geartronic AWD	V90 Cross Country T6 Geartronic AWD
Min. kerb weight, kg (actual kerb weight dependent on spec.)	1826	1813	1848	1834
Max. possible towing weight braked, kg	2400	2400	2500	2500
Max. towing weight unbraked, kg**	750	750	750	750
Max. towball weight, kg	110	110	110	110
Max. total weight, kg	2420	2400	2440	2420
Max. roof load, kg	100	100	100	100
Max. payload, kg (dependent on spec.)	594	587	592	586

All measurements in mm.

** Unbraked towing weight must not exceed 50% of kerb weight up to a maximum of approximately 750 kg.

NB Some of the information in this brochure may not be correct due to product changes which may have occurred since it was printed. Some of the equipment described or shown may now be available only at extra cost. Before ordering, please ask your Volvo dealer for the latest information. The manufacturer reserves the right to make changes at any time, without notice, to colour, materials, specifications and models.

Volvo Car South Africa.



Volvo Brand Experience.

DISCOVER THE ROOTS OF VOLVO CARS AND A WORLD OF SWEDISH ENJOYMENT.

Welcome to the Volvo Brand Experience, a unique way to experience more of your new Volvo. For R50,000.00 per couple, you will be able to enjoy:

- Two round-trip tickets.
- Two-night stay in Gothenburg, Sweden – the home of Volvo.
- An exciting tour to the Volvo factory and Volvo Museum.
- A special VIP experience at the exclusive Volvo Factory Delivery Centre.

This immersive experience will give you first-hand knowledge of what makes your new Volvo different.

T&C's apply, subject to availability.

"Cars are driven by people. The guiding principle behind everything we make, therefore is – and must remain – safety" Gustaf Larson and Assar Gabrielsson, Volvo's founders. These days we are driven by other things too, including innovative technology, beautiful design, environmental care and quality. All to ensure we continue to build great cars.



RED CARPET TREATMENT FROM START TO FINISH.

The programme includes two return tickets to Sweden from South Africa as well as luxury accommodation and dining for two days in the heart of Volvo's hometown, Gothenburg.

Once landed, a luxury Volvo transfer will pick you up and take you through to Gothenburg, where a new take on the world of Volvo and our Swedish heritage awaits. You'll visit our Torstlanda factory and see exactly how your Volvo is made, with a special behind-the-scenes tour and an English-speaking guide.

The Volvo Museum is also in the programme, where our rich lineage of cars is on display – including our concept cars, experimental technologies and our most famous production models.

You'll also enjoy a vehicle handover which matches your purchase. You'll be shown the ins and outs of your new car by a Volvo Brand Experience professional who will immerse you in your new world of Swedish luxury.

Of course, fine dining at a Michelin-starred restaurant will complete the experience, and you'll get a taste for traditional Swedish food like our traditional meatballs or *kottbullar*.

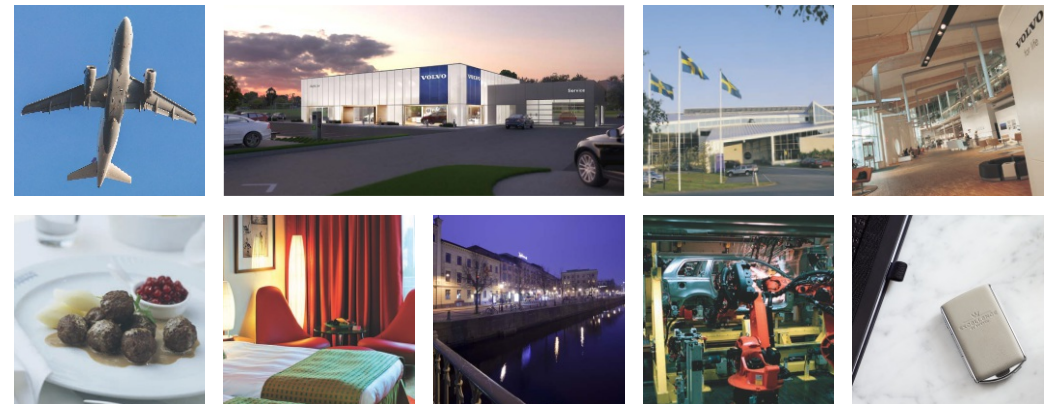







Volvo Car
Financial Services

A product of WesBank



Volvo Car
Financial Services

A product of WesBank

Volvo Car Road Side Assistance

On 1 January 2014, Tracker Connect became Volvo's new roadside assistance partner.

Services include:

- Medical emergency assistance
- Fuel assistance
- Recovery towing
- Emergency transportation
- "Stand by you" roadside security
- Free mobile app
- Web access to conveniently position your vehicle or draw reports which can be used to log and submit business or private usage to SARS.
- Volvo Car South Africa branded smartphone app
- Flat tyre assistance
- Battery service
- Overnight accommodation
- Accident towing
- Repatriation
- In-car Volvo Assist button
- Impact detection
- Mileage monitoring

Furthermore, the option to include Proactive Stolen Vehicle Recovery for as little as R199* per month is also available.

* Reviewed and adjusted annually.

The number to call is 0800 MYVOLVO (698 6586)

Volvo Car Financial Services

Volvo Car Financial Services has flexible financing options that enable you to structure your deal according to your specific requirements.

We want your experience of buying and owning a Volvo to be enjoyable and hassle-free. That is why we have developed the following online service tools:

- Online finance application – apply for finance any time of day or night and get an instant answer.
- Calculators – calculate your monthly repayments or calculate the value of a vehicle that you could buy based on a specified monthly repayment.
- Account services – manage your account in a secure and user-friendly online environment in real time.

So, remember to insist on Volvo Car Financial Services at your dealer or simply visit www.volvocars.com/za for more information.

Volvo Versatility Finance

For a tailor-made deal and guaranteed future value.

With best-in-class guaranteed future value across the entire Volvo range, it is a forward-thinking way to finance and future-proof your dream Volvo. When you reach the end of your finance period, you can renew, return or retain your Volvo. It is all up to you.

Flexibility today. Certainty tomorrow.

* Terms and conditions apply. As at time of print.



Volvo Car
Insurance

Volvo Car Insurance

Peace of mind. Our idea of luxury.

A Volvo-personalised insurance scheme. Highly competitive comprehensive insurance premiums available on all Volvo models.

Ask your Volvo dealer for more information.

Underwritten by Guardrisk Insurance Company (PTY) LTD, FSP NO:75. Administered by Insurance Underwriting Managers (PTY) LTD, FSP NO:21820.

* Terms and conditions apply.

V O L V O

All models standard with a 5 year / 100 000km Volvo Plan.

NB Some of the information in this brochure may not be correct due to product changes which may have occurred since it was printed. Before ordering, please ask your Volvo dealer for the latest information. The manufacturer reserves the right to make changes at any time, without notice, to colour, materials, specifications and models. Issued June 2017.

VOLVOCARS.COM/ZA