



SUBARU

OUTBACK





Inspiring out-of-office memos since '95.

Meet the 2022 Subaru Outback.

The first Outback wasn't just a way to get out there but a reason to see something new—to have an adventure. That was 1995, and still the Outback continues to push ahead. From its advanced technologies and safety systems to its capable engineering, this SUV lets you know the outdoors is waiting. So take a personal day—or two.

Most Adventurous

No idea is too far-out. With standard Subaru Symmetrical Full-Time All-Wheel Drive and a direct-injection SUBARU BOXER® engine, the Outback offers enhanced power and efficiency. There's also a turbocharged engine option¹ that delivers 260 horsepower and greater towing capability.



Most Reliable

Built on the strength of the Subaru Global Platform, the Outback has had years of experience on all types of terrain. Durability is at the heart of its engineering, from its direct-injection SUBARU BOXER® engine to its standard Subaru Symmetrical Full-Time All-Wheel Drive system.



1 Availability varies by trim level. See your retailer for details. 2 EyeSight® is a driver assist technology, which may not operate optimally under all driving conditions. The driver is always responsible for safe and attentive driving. System effectiveness depends on many factors such as vehicle maintenance, weather and road conditions. See Owner's Manual for complete details on system operations and limitations. 3 The DriverFocus® Distraction Mitigation System is a driver recognition technology designed to alert drivers if their attention to the road wavers or if the driver's face appears to turn away. The driver is always responsible for safe and attentive driving. System effectiveness may be affected by articles of clothing worn on the head or face. See Owner's Manual for complete details on system operation and limitations. 4 Apple CarPlay® is a registered trademark of Apple Inc. 5 Android™ is a trademark of Google LLC. 6 Requires Keyless Access with Push-Button Start and subscription to SUBARU STARLINK® Connected Services. Activation with subscription required. 3-year subscription included. See your retailer for details.

Safest

The Outback takes an active role in helping you stay safe, thanks to innovations such as standard Subaru EyeSight® Driver Assist Technology,² which includes Adaptive Cruise Control with Lane Centring Assist. There's also the DriverFocus® Distraction Mitigation System^{1,3} to help reduce distracted or drowsy driving.

Most Advanced

More options come with more ease in the Outback. An 11.6-inch tablet-style infotainment system¹ makes it intuitive to find the app you need through standard Apple CarPlay⁴ and Android™ Auto⁵ integration. With SUBARU STARLINK® Connected Services, you have Remote Engine Start with Climate Control,^{1,6} which lets you set the perfect temperature even before you get in.





**Savour that small amount
of time you spend inside.**



OUT TEMP
24°C

3:03 PM

SiriusXM-XM Preview

PASSENGER
AIR BAG

OFF

Map

Radio

Media

Phone

Apps

Car Info

SUBARU
STARLINK

MySubaru

Settings

VOLUME



× / HOLD

FRONT



21.0

On/Off

AUTO

A/C

22.5

Farther doesn't have to feel longer.

To keep distances engaging, the Outback delivers far-reaching connectivity, thanks to an 11.6-inch tablet-style infotainment system¹ and STARLINK[®] smartphone integration featuring Apple CarPlay^{®2} and Android[™] Auto.³ Once everyone votes on what music to play, the Harman Kardon[®] premium audio system^{1,4} will bring it to life through 12 speakers and a 576-watt-equivalent amplifier. With a standard heated steering wheel and heated front seats, along with available ventilated front seats,¹ your comfort zone is officially dialed in.



Harman Kardon[®] Premium Audio System^{1,4}



Heated Outboard Rear Seats¹ and Dual USB Charge Ports



Wireless phone charger¹



Ventilated front seats¹

¹ Availability varies by trim level. See your retailer for details. ² Apple CarPlay[®] is a registered trademark of Apple Inc.¹ ³ Android[™] is a trademark of Google LLC.¹ ⁴ Harman Kardon[®] is a registered trademark of Harman International Industries, Inc. ⁵ The DriverFocus[®] Distraction Mitigation System is a driver recognition technology designed to alert drivers if their attention to the road wavers or if the driver's face appears to turn away. The driver is always responsible for safe and attentive driving. System effectiveness may be affected by articles of clothing worn on the head or face. See Owner's Manual for complete details on system operation and limitations.



1 With seatback lowered. 2 Availability varies by trim level. See your retailer for details. 3 Requires Keyless Access with Push-Button Start and subscription to SUBARU STARLINK® Connected Services. Activation with subscription required. 3-year subscription included. See your retailer for details.



Rest stops aren't the only chances to stretch.

Expanding Possibilities

With up to 2144 litres of cargo space,¹ the Outback has room for a full range of adventures. A vast cargo area offers the convenience of a Hands-Free Power Rear Gate² and pop-up cargo cover, along with the versatility of a 60/40-split folding rear seatback. When it comes to comfort, you can ensure the Outback is at the perfect temperature even before you step in, thanks to SUBARU STARLINK® Connected Services featuring Remote Engine Start with Climate Control.^{2,3} Once inside, you're greeted by a 10-way power driver seat, heated front seats and a heated steering wheel. To further heighten the comfort of you and your passengers, available features include genuine Nappa Leather-trimmed seating,² an 8-way power passenger seat² and heated outboard rear seats.² When the moment calls for calm, you'll have as much as you need—this is the quietest Outback interior yet.



Hands-Free
Power Rear Gate²



Rear-seat comfort

Find a place that makes you forget to take a selfie.

All-New 2022 Outback Wilderness™

Your itinerary becomes anywhere in the Outback Wilderness—an Outback that's heightened, quite literally, with increased ground clearance. Rugged cladding and Anodized Copper-finish accents reveal its bold nature, while its capable engineering drives the point home. For more fun while taking on the terrain, the Outback Wilderness is equipped with an enhanced dual-function X-MODE® system, now designed to work at higher speeds. This is combined with off-road-optimized gearing as well as increased approach, departure and breakover angles for tackling a greater variety of surfaces.



Increased ground clearance



17-inch matte black alloy wheels with all-terrain tires



Protective under-body skid plates: front lower, engine, transmission and rear differential



U.S. model shown.



Roof rails with increased load capacity and Anodized Copper-finish accents

Versatile inside and out.

When you're far out there, the Outback Wilderness is designed to deliver confidence. Its ladder-type roof rails provide increased roof load capacity, while additional tow hook points and an LED rear gate light offer greater convenience. Inside, there's soft-touch all-weather upholstery along with an array of functional finishing touches, from rubber floor mats to all-weather second-row seat backs—and more.



Choose your engine.

With its low centre of gravity, the SUBARU BOXER® engine helps to enhance performance and handling. And with the Outback, you have two options. The direct-injection SUBARU BOXER® engine delivers capable performance with 182 hp. For more power with efficiency, the Outback XT and Outback Wilderness feature a 260-hp direct-injection turbocharged SUBARU BOXER® engine with 277 lb-ft of torque. Either way, you use only the fuel you need, as standard Auto Start Stop can shut off the engine when idling in traffic to save fuel.

182 HP
Direct-Injection Boxer Engine



260 HP

Direct-Injection Turbocharged Boxer Engine

Let your passion take you far.

Reliability for miles—and more.

Starting from its very core, the Outback is built for longevity. Subaru Symmetrical Full-Time All-Wheel Drive is the result of decades of Subaru expertise in full-time AWD engineering. The horizontally opposed design of the SUBARU BOXER® engine results in less vibration and wear-and-tear, and the Subaru Global Platform is simply our strongest foundation ever—incredibly durable and built to last.



An extra set of eyes every time you drive.

Every Outback includes standard Subaru EyeSight® Driver Assist Technology.¹

Equipped with a comprehensive suite of innovative safety features, EyeSight® looks ahead, alerts you to potential dangers and can even intervene to help you avoid a collision.



Pre-Collision Braking¹

Can help slow and bring your Outback to a full stop if necessary.



Lane Departure and Sway Warning¹

Can alert you if you drift to the edge of your lane and begin to cross into another.



Adaptive Cruise Control with Lane Centring Assist¹

Automatically keeps you centred in your lane, at a safe distance behind the car in front of you—even in traffic and around curves.

Pre-Collision Throttle Management¹

Can reduce your engine power to help give you more time to react and to help minimize the possible impact force and frontal impact damage.



Creating safer roads by reducing distracted driving.

Subaru is taking on one of the biggest issues in the automotive industry: distracted driving. The Outback features an award-winning, state-of-the-art safety system that helps reduce distracted driving for both new and experienced drivers. Working with EyeSight[®] Driver Assist Technology, DriverFocus^{®2,3} is like having an attentive co-pilot along for the ride, ready to give a helpful alert if a driver becomes distracted or drowsy.

¹ EyeSight[®] is a driver assist technology, which may not operate optimally under all driving conditions. The driver is always responsible for safe and attentive driving. System effectiveness depends on many factors such as vehicle maintenance, weather and road conditions. The Pre-Collision Braking System is designed to provide automatic braking that either prevents a collision or reduces the severity of a frontal impact. Pre-Collision Throttle Management is designed to reduce acceleration and minimize the severity of certain frontal impacts. Lane Centring Assist is designed to assist the driver and are not substitutes for safe and attentive driving. Lane centring function operates only when used in conjunction with Adaptive Cruise Control. The Lane Departure and Sway Warning, and Lane Keep Assist operate only when the lane markings are visible, and system effectiveness depends on many factors. See Owner's Manual for complete details on system operation and limitations. ² Availability varies by trim level. See your retailer for details. ³ The DriverFocus[®] Distraction Mitigation System is a driver recognition technology designed to alert drivers if their attention to the road wavers or if the driver's face appears to turn away. The driver is always responsible for safe and attentive driving. System effectiveness may be affected by articles of clothing worn on the head or face. See Owner's Manual for complete details on system operation and limitations.



Blind-Spot Detection

Using radar sensors, Blind-Spot Detection^{1,2} warns you with a visual indicator on your side mirror if it senses a vehicle in your blind spot. Another feature of this system, Lane Change Assist, alerts you with a flashing indicator on your side mirror if it senses a vehicle approaching at a higher speed in a neighbouring lane and you signal for a lane change.



Rear Cross-Traffic Alert

Rear Cross-Traffic Alert^{1,2} uses radar sensors to help warn you of traffic approaching from the side as you are backing up, using a flashing visual indicator on your side mirror and rearview camera display as well as an audible warning.

1 Availability varies by trim level. See your retailer for details. 2 Blind-Spot Detection, Lane Change Assist and Rear Cross-Traffic Alert are systems designed to assist the driver by monitoring the rear and side areas of the vehicle during a lane change or reversing and are not a substitute for safe and attentive driving. 3 The Reverse Automatic Braking System is not a substitute for safe and attentive driving. System effectiveness depends on many factors, such as vehicle maintenance, weather and road conditions. Always exercise caution and use vehicle mirrors and the rearview camera when backing up. See Owner's Manual for complete details on system operation and limitations. 4 Activation with subscription required.

Detect, alert, protect.

Advanced safety features

The Outback represents the very latest in Subaru safety, down to the strong core of its Subaru Global Platform. For better visibility, there are standard LED Steering Responsive Headlights as well as an available front-view camera.¹ Thanks to a wide range of active safety technologies, peace of mind is possible just about anywhere.



Reverse Automatic Braking

Reverse Automatic Braking¹³ can detect objects directly behind your vehicle when backing up at a low speed and can help bring the Outback to a stop should an object be detected within its range and the brakes have yet to be applied. There's also the rearview camera to help you keep an eye out.



SUBARU STARLINK® Connected Services

The Outback features SUBARU STARLINK® Connected Services technology,¹⁴ bringing you added safety, security and convenience. It can alert a first responder in an emergency, help police locate your vehicle if it's stolen and more. And to get you started, new Outback drivers enjoy a free three-year SUBARU STARLINK® Connected Services trial, which includes Advanced Automatic Collision Notification, Enhanced Roadside Assistance, SOS Emergency Assistance, and customizable vehicle alerts. It's control when you want it—and help when you need it.

2022 Outback | Features & Dimensions

11.6" tablet-style infotainment system¹



Standard EyeSight® Driver Assist Technology²



Standard LED Steering Responsive Headlights



SUBARU STARLINK® Connected Services with Remote Engine Start with Climate Control^{1,3}



Harman Kardon® 576-watt premium audio system with 12 speakers^{4,5}



Genuine Nappa Leather⁶

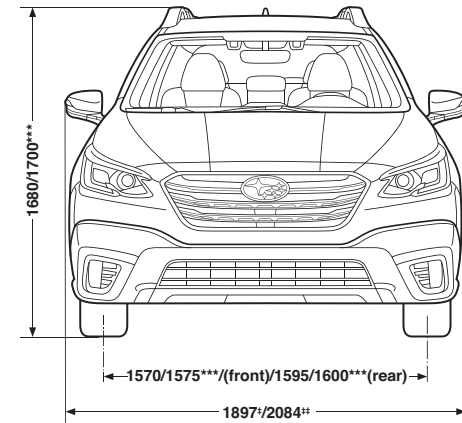
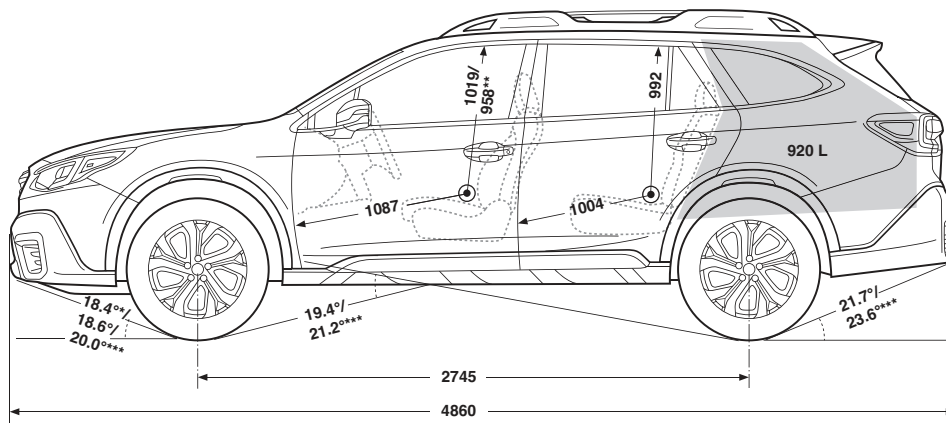

Measurements in millimetres unless specified

* Limited and Premier trims.

** With available sunroof.

*** Wilderness trim.

‡ With mirrors folded.

‡‡ With mirrors extended.

For a detailed list of specifications, features, accessories and model comparisons, please visit Subaru.ca or your nearest authorized Subaru Retailer.

1 Not available on Convenience trim. 2 EyeSight® is a driver assist technology, which may not operate optimally under all driving conditions. The driver is always responsible for safe and attentive driving. System effectiveness depends on many factors such as vehicle maintenance, weather and road conditions. The Pre-Collision Braking System is designed to provide automatic braking that either prevents a collision or reduces the severity of a frontal impact. The Pre-Collision Throttle Management System is designed to reduce acceleration and minimize the severity of certain frontal impacts. Adaptive Cruise Control is designed to assist the driver and is not a substitute for safe and attentive driving. The Lane Departure and Sway Warning and Lane Keep Assist operate only when the lane markings are visible, and system effectiveness depends on many factors. See Owner's Manual for complete details on system operation and limitations. 3 Activation with subscription required. 4 Limited and Premier trims only. 5 Harman Kardon® is a registered trademark of Harman International Industries, Inc. 6 Premier trims only. 7 Apple CarPlay® is a registered trademark of Apple Inc. 8 Android™ is a trademark of Google LLC. 9 Bluetooth® is a registered trademark of Bluetooth SIG, Inc., America. 10 Activation and required monthly subscription sold separately. Includes 3-month trial subscription. See your retailer for details. SiriusXM®, Traffic®, Travel Link®, and the SiriusXM logo, channel names and logos are trademarks of Sirius XM Radio Inc. and are used under licence by Sirius XM Canada Inc. Subscriptions to SiriusXM Canada are subject to the SiriusXM Canada Customer Agreement and other terms and conditions. 11 HomeLink® is a registered trademark of Gentex Corporation. 12 Blind-Spot Detection, Lane Change Assist and Rear Cross-Traffic Alert are systems designed to assist the driver by monitoring the rear and side areas of the vehicle during a lane change or reversing and are not a substitute for safe and attentive driving. 13 The Reverse Automatic Braking System is not a substitute for safe and attentive driving. System effectiveness depends on many factors, such as vehicle maintenance, weather and road conditions. Always exercise caution, and use vehicle mirrors and the rearview camera when backing up. See Owner's Manual for complete details on system operation and limitations. 14 Trailer brakes may be needed. Some safety features, including X-MODE®, Blind-Spot Detection and Rear Cross-Traffic Alert, may not function properly when towing. See your retailer for details. 15 The DriverFocus® Distraction Mitigation System is a driver recognition technology designed to alert drivers if their attention to the road wavers or if the driver's face appears to turn away. The driver is always responsible for safe and attentive driving. System effectiveness may be affected by articles of clothing worn on the head or face. See Owner's Manual for complete details on system operation and limitations.

2022 Outback | Trim Levels



Convenience

- 182-hp 2.5-litre 4-cylinder SUBARU BOXER® engine with direct-injection
- Auto Start Stop
- EyeSight® Driver Assist Technology²
- Subaru Symmetrical Full-Time All-Wheel Drive
- Lineartronic® CVT (Continuously Variable Transmission) with Active Torque Vectoring
- X-MODE® featuring Hill Descent Control
- LED Steering Responsive Headlights with High Beam Assist
- LED fog lights
- Roof rails with integrated retractable crossbars and 4 tie-down hooks
- Heated body-colour side mirrors with integrated turn signals
- Privacy glass
- Cloth upholstery
- 10-way power-adjustable driver seat with lumbar support and 4-way manually adjustable front-passenger seat
- Heated front seats
- Leather-wrapped heated steering wheel
- Dual rear-seat USB charge ports
- Automatic climate control
- Driver and front-passenger auto-up/down power windows
- Pop-up cargo-area cover, 4 tie-down hooks and 2 grocery bag hooks
- Rearview camera with dynamic guidelines and rear washer
- Front- and rear-passenger seatbelt warning light and chime
- Dual 7-inch infotainment system with high-resolution touchscreen display, AM/FM/MP3/WMA audio system with Apple CarPlay®⁷ and Android™ Auto⁸ functionality, USB port control, auxiliary audio input, steering wheel-integrated controls, Bluetooth®⁹ mobile phone connectivity with voice activation and Bluetooth®⁹ streaming audio, and SiriusXM® Satellite Radio¹⁰ and Travel Link®¹⁰



Limited

Includes Touring key features and adds/upgrades:

- DriverFocus® Distraction Mitigation System¹⁵
- 18-inch aluminum-alloy wheels
- Silver front and rear bumper underguards
- Leather-trimmed upholstery
- 8-way power-adjustable front-passenger seat
- Adjustable driver seat thigh support
- Two-position memory driver seat and exterior mirrors
- Heated outboard rear seats
- 12-speaker, 576-watt-equivalent Harman Kardon® audio system
- Auto-dimming rearview compass mirror with HomeLink®¹¹
- Wireless phone charger
- 11.6-inch tablet-style infotainment system with high-resolution touchscreen display, GPS navigation, AM/FM/MP3/WMA audio system with Apple CarPlay®⁷ and Android™ Auto⁸ functionality, USB port control, auxiliary audio input, steering wheel-integrated controls, Bluetooth®⁹ mobile phone connectivity with voice activation and Bluetooth®⁹ streaming audio, and SiriusXM® Satellite Radio,¹⁰ Traffic,¹⁰ and Travel Link®¹⁰

Limited XT

Includes Limited key features and adds:

- 260-hp 2.4-litre 4-cylinder Direct-Injection Turbocharged (DIT) SUBARU BOXER® engine with high-torque Lineartronic® CVT (Continuously Variable Transmission) and 1588 kg max towing capacity¹⁴
- Exclusive XT badging
- Exclusive XT floor mats



Touring

Includes Convenience key features and adds/upgrades:

- 17-inch aluminum-alloy wheels
- Power tilting and sliding glass sunroof
- Hands-Free Power Rear Gate with vehicle lock button
- Auto-dimming side mirrors with approach lighting
- Auto-dimming rearview mirror with HomeLink®¹¹
- Windshield wiper de-icer
- Auto-up/down front and rear windows
- Dual-zone automatic climate control with synchronization
- Leather-wrapped shifter handle
- Centre console rear vents
- Cargo-area tray
- Proximity key with Push-button Start
- Subaru Side/Rear Vehicle Detection (SRVD) system with Blind-Spot Detection and Rear Cross-Traffic Alert¹²
- Reverse Automatic Braking¹³
- 11.6-inch tablet-style infotainment system with high-resolution touchscreen display, AM/FM/MP3/WMA audio system with Apple CarPlay®⁷ and Android™ Auto⁸ functionality, USB port control, auxiliary audio input, steering wheel-integrated controls, Bluetooth®⁹ mobile phone connectivity with voice activation and Bluetooth®⁹ streaming audio, and SiriusXM® Satellite Radio¹⁰ and Travel Link®¹⁰
- SUBARU STARLINK® Connected Services³ (free 3-year trial subscription included)



Premier

Includes Limited key features and adds:

- Automatic power-folding exterior mirrors with Satin chrome finish
- Silver-accented roof rails with integrated retractable crossbars and 4 tie-down hooks
- Chrome-accented exterior door handles
- Front-view camera
- Brown Nappa Leather-trimmed upholstery
- High-grade leather-wrapped steering wheel
- Ventilated front seats
- Centre console mounted single-disc CD player

Premier XT

Includes Premier key features and adds:

- 260-hp 2.4-litre 4-cylinder Direct-Injection Turbocharged (DIT) SUBARU BOXER® engine with high-torque Lineartronic® CVT (Continuously Variable Transmission) and 1588 kg max towing capacity¹⁴
- Exclusive XT badging
- Exclusive XT floor mats



Wilderness

Includes Touring key features and adds/upgrades:

- 260-hp 2.4-litre 4-cylinder Direct-Injection Turbocharged (DIT) SUBARU BOXER® engine with high-torque Lineartronic® CVT (Continuously Variable Transmission) and 1588 kg max towing capacity¹⁴
- Off-road optimized gearing
- Enhanced Dual-Function X-MODE® with Snow/Dirt and Deep Snow/Mud modes, low speed/low ratio gradient control and medium-to-high-speed gravel/dirt functions
- Off-road tuned suspension with increased ground clearance
- 4 tow points with Anodized Copper-finish covers
- 17-inch aluminum-alloy wheels with matte black finish and Yokohama® Geolandar® All-Terrain tires
- Hexagonal LED fog lights
- Outback Wilderness-design front and rear bumper covers, fender flares and side cladding
- Outback Wilderness-design front grille
- Matte-black, anti-glare hood decal
- Front lower, engine, transmission and rear differential skid plates
- Fixed ladder-style roof rails with increased load-carrying capacity, 4 tie-down points and Anodized Copper-finish accents
- Subaru Wilderness badging on front doors and rear gate
- Black badging and window moldings
- Full-size spare tire
- Outback Wilderness soft touch all-weather upholstery with Anodized Copper-finish accents and contrast stitching
- Outback Wilderness-design all-weather floor mats
- Outback Wilderness gauges with colour LCD display and anodized copper accents
- LED rear gate light
- Heated outboard rear seats
- Front-view camera
- Auto-dimming rearview compass mirror with HomeLink®¹¹
- Wireless phone charger

2022 Outback | Colours

Exterior Colours



Crystal White Pearl



Ice Silver Metallic



Brilliant Bronze Metallic



Autumn Green Metallic



Abyss Blue Pearl

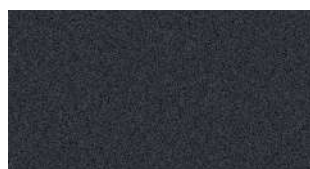

Magnetite Grey Metallic

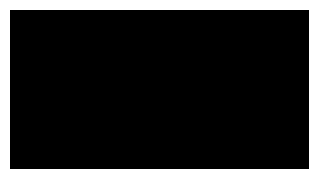

Crystal Black Silica



Geyser Blue

Seat Material

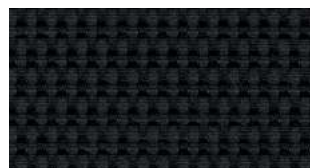

Black Cloth (BC)

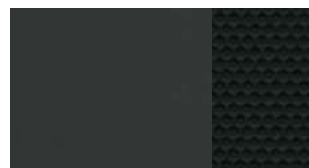

Wilderness Grey Soft-touch
All-weather Upholstery (GST)



Black Leather (BL)



Ivory Leather (IL)



Brown Nappa Leather (BNL)

Colour Combinations	Convenience	Touring	Wilderness	Limited and Limited XT	Premier and Premier XT
Crystal White Pearl	BC	BC	GST	BL	BNL
Ice Silver Metallic	BC	BC	GST	BL	–
Brilliant Bronze Metallic	–	BC	–	BL or IL	–
Autumn Green Metallic	–	BC	GST	BL	BNL
Abyss Blue Pearl	BC	BC	–	BL	BNL
Magnetite Grey Metallic	BC	BC	GST	BL	BNL
Crystal Black Silica	BC	BC	GST	BL	BNL
Geyser Blue	–	–	GST	–	–



Subaru Warranties

Every Subaru vehicle is designed and built to offer our customers the highest possible level of quality and reliability. We are proud of our vehicles and proud to stand behind them with a comprehensive warranty. For 2022 model-year vehicles, the warranty on all Subaru vehicles consists of the following:

New Vehicle Limited Warranty (36 month/60,000 km) – Covers basic and major components for 36 months or 60,000 km.

Major Component Limited Warranty (60 month/100,000 km) – Extends coverage of major components (more than just powertrain) up to 60 months or 100,000 km.

Surface Corrosion Limited Warranty (36 month/60,000 km) – Covers surface corrosion to visible painted body panels for 36 months or 60,000 km.

Anti-Perforation Limited Warranty (60 month/unlimited km) – Covers perforation due to corrosion to body sheet metal panels for 60 months, regardless of kilometres.

Emission Control System Limited Warranty – Covers some emissions components for 36 months or 60,000 km and the major parts of the emission control system for 96 months or 130,000 km.

Parts and Accessories Limited Warranty – Covers Subaru parts and accessories installed by the retailer prior to retail delivery of the vehicle for 36 months or 60,000 km, and Subaru parts and accessories installed by the retailer after the retail delivery of the vehicle for 12 months or 20,000 km from the date of the installation.

The above information is an overview of warranty coverage and is not a warranty statement. If you wish to see more details regarding Subaru warranties, please refer to your Subaru warranty booklet, contact your local retailer or visit our Web site at subaru.ca.

Subaru 360 C.A.R.E. Program (36 months/unlimited km)

Access to dedicated Subaru 360 C.A.R.E. (Customer Assistance for Roadside Emergencies) Roadside Assistance Services, which includes access to 1,000 CAA and AAA offices throughout Canada and the United States. In addition to towing, coverage also includes Fuel Delivery, Battery Boost, Flat Tire Service, Lock-Out Service, Trip Accident & Mechanical Breakdown Assistance Service, Winching and Extrication Service, Personalized Trip Planning and Routing, Theft and Hit-and-Run Reward, and Arrest Bond Certificate.

The above information is an overview of services. If you wish to see more details regarding Subaru 360 C.A.R.E., please visit our Web site at subaru.ca.

Subaru Protection Plan

As a Subaru owner, you have expectations for a pleasurable, trouble-free ownership experience – now and into the future. Once your 36-month/60,000-km New Vehicle Limited Warranty period ends,¹ our Subaru Protection Plan (SPP) – the only vehicle service contract endorsed by Subaru Canada for Subaru vehicles – can prolong your hassle-free ownership experience with three levels of extended service contract coverage tailored to your needs: Powertrain Protection; Major Protection; or Complete Protection (best level of coverage to complement the 60-month/100,000-km Major Component Limited Warranty). SPP offers comprehensive mechanical and electrical coverage and a number of additional features and benefits, such as Roadside Assistance and Alternate Transportation, for up to 7 years or 160,000 kilometres from your vehicle's in-service date. Whether your vehicle is purchased or leased, SPP protects you and your investment. Be sure to ask your retailer for details or visit subaru.ca.

¹ If you already own a Subaru vehicle and it is still within the 36-month/60,000-km New Vehicle Limited Warranty period, you are still eligible for SPP.

Subaru vehicles are uniquely designed to get out there more and to leave less behind. We build our vehicles for maximum longevity, because more time spent on the road equals less time spent in junkyards and landfills. In fact, 96.7% of our vehicles sold in Canada over the last 10 years are still on the road today¹. You'll also find very little waste created in the production of a Subaru. Many of our vehicles are built in the Subaru of Indiana Automotive, Inc., (SIA) factory, which was the first manufacturing facility in the U.S. to achieve zero-landfill status. Other Subaru facilities around the world now achieve similar goals in helping to preserve the environment. Respect for our surroundings is yet another way that Subaru vehicles help to build driver confidence for the road ahead.

¹ Based on IHS Markit Vehicles in Operation as of June 30, 2020, for Model Years 2011 to 2020 vs. Total New Registrations of those vehicles.



For a detailed list of specifications, features, accessories and model comparisons, please visit Subaru.ca or your nearest authorized Subaru Retailer.

The Supplemental Restraint System (SRS airbags) affords the driver and passenger additional protection in some collisions. This system provides supplemental protection only, and seatbelts must be worn in order to avoid injuries to out-of-position occupants upon airbag deployment. The combination of SRS and seatbelts provides the best protection in a serious accident. All illustrations, specifications, features and photographs contained in this brochure are based on product information available at the time of its printing and may not be completely accurate following its publication. Colours shown may vary due to reproduction variations in the printing process, and some vehicle parts cannot be shown in certain photographs. Subaru Canada, Inc. reserves the right to discontinue or make changes at any time, without notice or incurring obligations, to colours, materials, equipment, accessories, features, specifications and models, or to change their prices. Some models shown may be from international markets and are not available in Canada; may be shown with equipment or accessories that are optional (at extra cost) or available only in certain combinations; or may be subject to product delays or not be available in Canada. Please visit subaru.ca for the latest information and specifications. For complete details on product updates and warranties, please contact your Subaru retailer. Ascent, BRZ, Crosstrek, DriverFocus, Forester, EyeSight, Impreza, Legacy, Outback, WRX, STI, Lineartronic, X-MODE, STARLINK, Subaru and SUBARU BOXER are registered trademarks of SUBARU CORPORATION. Android™ is a trademark of Google LLC.[†] Apple CarPlay® is a registered trademark of Apple Inc.[†] Bluetooth® is a registered trademark of Bluetooth SIG, Inc., America. Harman Kardon® is a registered trademark of Harman International Industries, Inc. HomeLink® is a registered trademark of Gentex Corporation. "SiriusXM®", "SiriusXM® Traffic," "SiriusXM Travel Link®" and the SiriusXM logo, channel names and logos are trademarks of Sirius XM Radio Inc. and are used under licence by Sirius XM Canada Inc. Subscriptions to SiriusXM Canada are subject to the SiriusXM Canada Customer Agreement and other terms and conditions. [†] Ability of this product to access connected content is subject to change without notice and could be affected by any of the following: compatibility issues with future firmware versions of the smartphone; compatibility issues with future versions of the connected content application(s) for the smartphone; changes to or discontinuation of the connected content application(s) or service by its provider. Printed in Canada. © 2021 Subaru Canada, Inc. 2022 model year.



Environmental Management System
(EMS) ISO 14001:2015 certified by SGS

This booklet was printed on FSC® certified paper and contains 55% recycled fibre. It is chlorine-free, recyclable and biodegradable. FSC® (Forest Stewardship Council®) is an international organization that brings people together to find solutions that promote responsible management of the world's forests. This booklet was also produced using a "GREEN" printing process, which includes vegetable-based inks that leave no harmful residue. Please recycle.



subaru.ca

SUBARU CANADA, INC.

560 Suffolk Court, Mississauga, ON, L5R 4J7