



www.alfaromeo.co.za



Sportiness and style.

A creative concept that combines the elegance of a sedan with the spirit of a real gran turismo. Strong and harmonious lines, designed by the passion of Giorgetto Giugiaro and the Alfa Romeo Style Centre. Muscular features firmly planted on the asphalt, ready to turn every trip into a lifetime experience. Inside, finely crafted finish and extreme functionality combine to enfold you in a secure embrace. Meet the Alfa Romeo 159. Now also with new outfits and colours.





Even more powerful, even lower fuel consumption.

Alfa Romeo power unit engineering continues to evolve by offering increasingly competitive performance with regard to power and fuel consumption. This is borne out by the 147 kW 1750 Turbo Petrol that boasts a maximum torque level (320 Nm) available even from the lowest speeds (1400 rpm) that remains constant to 2000 rpm. Absolutely outstanding values to ensure excellent pick-up performance and limit the use of the gearbox by the driver. [The 159 engine complies with Euro 5 standards.](#)



Performance

Thoroughbred sports car.

The 159 engine range is ready to meet all your driving needs but, above all, the satisfaction of being behind the wheel of a thoroughbred sports cars.

Two petrol units, both powerful and flexible. From the 147 kW 1750 Turbo Petrol to the 191 kW 3.2 V6.



	1750 Turbo Petrol 147 kW	3.2 V6 191 kW
Displacement	1742 cm ³	3195 cm ³
Torque	320 Nm at 1400 rpm	322 Nm at 4500 rpm
Gearbox	6-speed manual	6-speed manual and automatic
CO ₂	182	260 (270 - Q4 Q-Tronic)
Environmental classification	Euro 5	Euro 4

Enjoy yourself behind the wheel!

That's exactly what happens when you grip the steering wheel and press down on the accelerator of an Alfa Romeo 159. Because that's when the raised double wishbone front suspension – a technology derived from the world of motor racing and applied exclusively by Alfa Romeo – comes into its own. This advanced suspension system ensures precise, linear steering, better traction and reduced pitching under braking. At the rear, multilink suspension controls wheel movement to ensure constantly optimised traction and grip. Alfa Romeo has developed the Electronic Q2 system precisely to make the most of this high-performance suspension. Electronic Q2 uses the ESP control unit to create an effect similar to that of a limited slip differential, but using the car's braking system instead. The system combines the benefits of front-wheel drive and four-wheel drive to improve road holding, traction and stability. The end result is highly effective sporting suspension and a feeling of complete control that only the 159 can offer.



Technology and control

A 5-star rating. The ultimate in motoring safety.

The new 159 also incorporates all the usual electronic safety systems including ABS with EBD, VDC electronic stability control, ASR anti-slip control, HBA emergency braking assistance and Hill Holder for effortless hill-starts plus a servo-assisted braking system that ensures responsive and progressive braking action and extremely short stopping distances.

The 159 is built to protect. And a maximum score in Euro NCAP safety tests shows that this objective has been easily achieved. 5 stars for the torsional rigidity of the body shell made from high strength steel, dual-phase steel and multi-thickness steel sheet, rigidly joined transversely and vertically using laser welding technology. 5 stars for the non-deformable floor pan, lateral beams and rigid engine mounting structure. There are even front, side, knee and window airbags to provide total protection.

And we've thought of your children's safety too and provided a three-point rear seat attachment for Isofix child seats.

Alfa Romeo 159 heads its category for active and passive safety. Because its equipment is so comprehensive, it received the most prestigious acknowledgement in the motoring safety field: a EuroNCAP 5 star rating.









Progression Outfit.

Innovative style, advanced technology.

17" alloys • 3D Sport cloth seats • Black Interior • Dual zone automatic climate control
• Leather-trimmed steering wheel and gear lever knob • Control panel with white lighting
• Electric rear windows • Radio/CD • Chrome-plated exhaust tail pipe • Third rear head restraint.

Available on:

• 1750 Turbo Petrol 147 kW Progression.

Progression







Distinctive Outfit.

For those that want more than standard fare. For those who want a 159 unlike any other.

17" spoked alloys • Leather and cloth seats • Sports steering wheel and gear lever knob in leather with black top-stitching • Panels in brushed black aluminium • Radio controls on the steering wheel • Cruise control • Sports control panel with white lighting • Dual zone automatic climate control • Fog lamps • Radio/CD with mp3 player.

Available on:

3.2 V6 Distinctive

3.2 V6 Q4 Q-Tronic Distinctive



Distinctive





Ti.

A pure distillate of Alfa Romeo sportiness. No uncertainties. No compromises.

Distinctive equipment, plus:

18" turbine alloys • Low ride • Red brake calipers • Side skirts • Seats in leather and Alcantara in sports configuration • Sports steering wheel and gear lever knob in leather with red top-stitching • Blue&Me™ • Sports pedal unit • Heated seats • Sill plate in aluminium with Ti logo

Available on:

1750 Turbo Petrol 147 kW

3.2 V6



Ti







Technical specifications

159 Dimensions

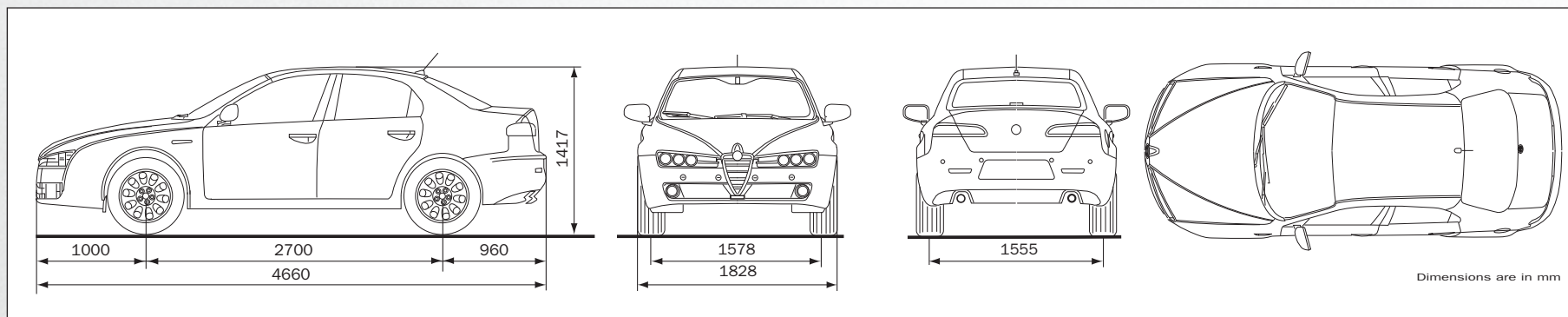

CHARACTERISTICS	1750 TBI Progression - 3.2 Distinctive - 3.2 Q4 Q-Tronic Distinctive	1750 TBI - 3.2 TI
Dimensions		
No. of seats	5	5
No. of doors	4	4
Length (mm)	4660	4660
Weight (mm)	1828	1828
Height (mm)	1422	1402
Wheelbase (mm)	2700	2700
Front track (mm)	1578	1578
Rear track (mm)	1555	1555
Luggage space (dm ³)	405	405



Technical data

	1750 TBI		3.2	
	1750 TBI 147 kW Progression	1750TBI 147 kW Ti	3.2 191 kW Distinctive & 3.2 191 kW Ti	3.2 191 kW Q4 Q-Tronic Distinctive
Characteristics				
Number of cylinders, arrangement	4 in line		V6	
Bore x stroke (mm)	83,0 x 80,5		89,0 x 85,6	
Displacement (cu. cm)	1742		3195	
Compression ratio	9,5 : 1		11,25 : 1	
Max. power output HP (kW-EC) at rpm	147 at 5000		191 at 6200	
Peak torque Nm (kgm-EC) at rpm	320 at 1400		322 at 4500	
Timing system	2 OHCs (chain), 4 valves per cylinder, double electro-hydraulic continuous phase variators		4 OHCs (chain), 4 electro-hydraulic continuous phase variators	
Fuel feed	Turbocharger with MED direct injection integrated with ignition, with scavenging function		MED 7.6.1 electronic direct injection integrated with ignition	
Exhaust pipe	Double with separate mufflers and chrome tips		Double with separate mufflers and chrome tips	
Electrical system (12V)				
Battery: capacity (Ah) / Generator (A)	60/120		70/120	
Transmission				
Gearbox	6-speed manual		6-speed manual	6-speed automatic
Traction	Front		Front	4 Wheel
Number of gears	6 + 1R		6 + 1R	Auto. 6 + 1R
Final ratio	3.94			
Tyres				
Standard version	225/50 R17	235/45 R18	225/50 R17	235/45 R18
Steering				
Steering system	Rack and pinion with hydraulic servo		Rack and pinion with hydraulic servo	
Steering diameter kerb-to-kerb (m)	11.1		11.1	
Suspension				
Front	High double wishbone		High double wishbone	
Rear	Multilink architecture		Multilink architecture	
Brakes (discs)				
Front (mm)	Ventilated 330 x 28 D, fixed radial caliper in aluminium with four 42 mm pistons		Ventilated 330 x 28 D, fixed radial caliper in aluminium with four 42 mm pistons	
Rear (mm)	292 x 22 D; combined 42 mm floating caliper		292 x 22 D; combined 42 mm floating caliper	
Capacities - weights				
Fuel tank (l)	70		70	
Kerb weight DIN (kg)	1430		1540	1610
Max towable weight (kg)	1500		1700	
Performance				
Top speed (km/h)	235		250	244.0
Acceleration (driver + 30 kg) 0-100 km/h (s)	7.7		7.1	7.0
Acceleration (driver + 30 kg) 0-1000 m (s)	28.9		27.0	27.3
Fuel Consumption - Emissions SI/SW Acc. To 1999/100/EC				
Urban cycle (l/100 km)	11.3		16.4	16.7
Extra-urban cycle	5.8		7.9	8.3
Combined cycle	7.8		11.0	11.4
Exhaust emissions CO ₂ (g/km)	182		260	270
Emissions standard	Euro 5		Euro 4	

Standard equipment and options

EXTERIOR EQUIPMENT	159 1750 TBI PROGRESSION	159 1750 TBI TI	159 3.2 DISTINCTIVE	159 3.2 TI	159 3.2 Q4 Q-TRONIC DISTINCTIVE
Double chrome exhaust tailpipe	•	-	•	-	•
Ti exhaust	-	•	-	•	-
Aluminium brake calipers with Alfa Romeo designation	•	-	•	-	•
Sports set up with red Brembo brake calipers with Alfa Romeo designation	-	•	-	•	-
Electrically folding side mirrors	•	•	•	•	•
Electrically operated sunroof with anti-crush seal	○	○	○	○	○
Sports skirts	-	•	-	•	-
Metallic paint finish (Colours 565, 657, 651, 660, 876)	○	○	○	○	○
Alfa Red paint finish (Extra Series Pastel colour 289)	○	○	○	○	○
Competizione Red (8C Triple Layer colour 115)	○	○	○	○	-
17" spoke design alloy wheels with 225/50 tyres	•	-	•	-	•
17" spoke design alloy wheels with 225/50 tyres	○	-	○	-	○
18" turbine design alloy wheels with 235/45 tyres	○	-	○	-	○
18" turbine design alloy wheels with matt black finish	-	•	-	•	-
Fog lights	•	•	•	•	•
Halogen headlights	•	•	•	•	•
Bi-Xenon headlights	-	○	-	-	-
PDC	○	○	○	○	○

● = standard ○ = optional - = not available

Standard equipment and options

INTERIOR EQUIPMENT	159 1750 TBI PROGRESSION	159 1750 TBI TI	159 3.2 DISTINCTIVE	159 3.2 TI	159 3.2 Q4 Q-TRONIC DISTINCTIVE
Electric front and rear windows with anti-crush function	•	•	•	•	•
Rear seat headrests	•	•	•	•	•
Mechanical adjustment for recline angle on driver and passenger seats	-	•	-	•	-
Black interior (black roof, parcel shelf and upright covers)	•	•	•	•	•
Front armrest with storage compartment and cooler compartment	•	•	•	•	•
Electronic key with remote central locking and boot release	•	•	•	•	•
Electronic key with start button	•	•	•	•	•
Sill insert with Ti decal	-	•	-	•	-
Interior black trim	•	-	-	-	-
Interior trim in black aluminium	-	•	•	•	•
Dual zone automatic climate control with split temperature and distribution function (air nozzles at the rear, pollen filter)	•	•	•	•	•
Cruise control	•	•	•	•	•
Smokers' kit	•	•	•	•	•
Sports pedals and aluminium heel guard	-	•	-	•	-
60/40 split folding rear seats	-	•	•	•	•
Leather upholstery	○	-	○	-	○
Sports 3D fabric upholstery	•	-	-	-	-
Sports leather and alcantara upholstery	-	•	-	•	-
Leather/fabric upholstery	-	-	•	-	•
Heated front seats	-	•	-	•	-
On-board instrumentation with sports graphics, white backlighting and multifunctional display	-	•	•	•	•
Trip computer (two independent devices for range, fuel consumption, average speed, distance travelled)	•	•	•	•	•
Leather steering wheel and gear knob with angle and reach adjustment	•	-	-	-	-
Sports leather steering wheel and gear knob with black stitching, angle and reach adjustment	-	-	•	-	•
Sports leather steering wheel and gear knob with red stitching, angle and reach adjustment	-	•	-	•	-

● = standard ○ = optional - = not available

Standard equipment and options

SAFETY/MECHANICAL PARTS	159 1750 TBI PROGRESSION	159 1750 TBI TI	159 3.2 DISTINCTIVE	159 3.2 TI	159 3.2 Q4 Q-TRONIC DISTINCTIVE
Full-size driver and passenger front airbags with controlled inflation	•	•	•	•	•
Front side airbags (chest and pelvis protection)	•	•	•	•	•
Window airbags	•	•	•	•	•
Driver's knee airbag	•	•	•	•	•
Front passenger airbag deactivation key	•	•	•	•	•
Alfa code Immobilizer	•	•	•	•	•
Isofix attachments on rear seats	•	•	•	•	•
Anti-intrusion bars in front and rear doors	•	•	•	•	•
Front seat belts with load limiter and pretensioner	•	•	•	•	•
"Follow me home" headlights	•	•	•	•	•
Fire prevention system	•	•	•	•	•
Normal size alloy spare wheel	•	•	•	•	•
Brake pad wear and braking system failure sensor	•	•	•	•	•
Child safety locks on rear doors	•	•	•	•	•
Fuel cap secured by central locking	•	•	•	•	•
VDC with Hill Holder (ABS + ASR + EBD + Brake Assistance)	•	•	•	•	•
Electronic Q2	•	•	-	-	-

● = standard ○ = optional - = not available



Standard equipment and options

AUDIO/PHONE/ACCESSORIES	159 1750 TBI PROGRESSION	159 1750 TBI TI	159 3.2 DISTINCTIVE	159 3.2 TI	159 3.2 Q4 Q-TRONIC DISTINCTIVE
Car radio with CD player	•	–	–	–	–
Car radio with CD and MP3 player	–	•	•	•	•
Hi-Fi Bose® sound system with digital amplifier (8 speakers + 1 central + subwoofer)	–	○	–	–	–
Blue&Me™ (Bluetooth™ hands-free system with voice recognition and MP3 player with USB port)	○	•	•	•	•
Radio/communications controls on steering wheel	•	–	–	–	–
Radio/communications controls on sports steering wheel	–	•	•	•	•
Visibility pack (rain, dusk and condensation sensors, air quality system and electrochromic rearview mirror)	○	•	•	•	•
SERVICE PLAN/WARRANTY/ROADSIDE ASSISTANCE					
Service plan: 6 years/105 000 km	•	•	•	•	•
Service intervals: 35 000 km	•	•	•	•	•
Warranty: 5 years/150 000 km	•	•	•	•	•
3 years' roadside assistance	•	•	•	•	•

● = standard ○ = optional – = not available

Colour Combinations

Model	1750 TBI Progression		1750 TBI TI	3.2 TI	3.2 Distinctive	3.2 Q4 Q-Tronic Distinctive	1750 TBI Progression	3.2 Distinctive		3.2 Q4 Q-Tronic Distinctive		
	Sports Fabric		Sports Leather - Alcantara		Mixed Fabric - Leather Venus		Leather (Opt 211)					
Interior Code	298	288	878		398		402	402	445	401	402	445
Dash	Black	Black	Black		Black		Black	Black	Black/Beige	Black	Black	Black/Beige
Seat	Sports fabric 3D grey	Sports fabric 3D red	Black sports leather/Alcantara		Black leather/fabric		Black leather	Black leather	Beige leather	Red leather	Black leather	Beige leather
METALLIC (210)												
565 Alfa Silver	•	–	•	•	•	•	–	•	–	–	•	•
660 Indaco Grey	•	–	–	–	–	–	–	–	–	–	–	–
567 Oltremare Blue	–	–	–	–	–	–	•	•	–	–	–	•
651 Stromboli Grey	–	–	•	–	•	•	•	–	•	•	–	–
876 Carbonio Black	–	–	•	–	–	–	–	–	–	–	–	•
PASTEL												
601 Black	–	–	•	•	•	–	–	–	–	–	–	–
296 Ghiaccio White	•	–	•	•	•	•	•	–	•	–	•	–
EXTRA SERIES PASTEL (5B2)												
289 Alfa Red	–	•	•	•	•	•	•	•	–	•	–	–
TRIPLE-LAYER PEARLESCENT (4SA)												
115 Competizione Red (8C Red)	•	–	•	•	•	–	–	–	–	–	–	–

• = available – = not available



Wheels



Accessories



17" alloy kit

18" alloy kit

19" alloy kit

Side skirts



Rear bumper spoiler

Rear boot spoiler

Front bumper spoiler

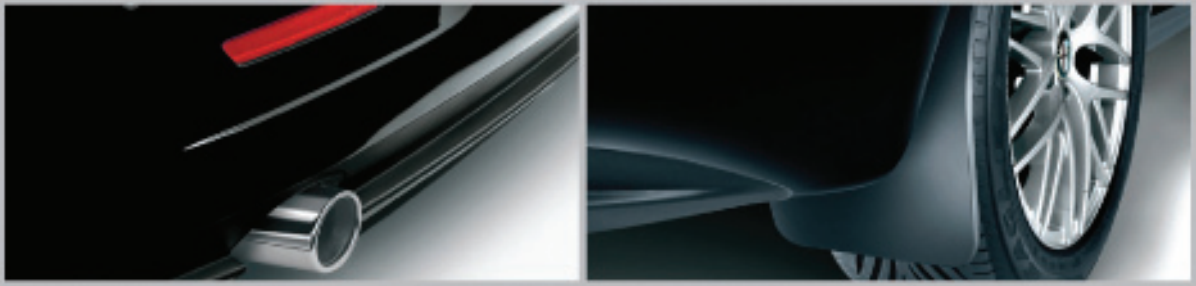

Chrome exhaust pipe

Rear mud flap set 2pc



Alfa Romeo Services

Customers who choose an Alfa Romeo car know that they can count on a vehicle that is technologically innovative with state-of-the-art safety but also on a world of solutions and services, designed to meet all the needs of both car and driver.

The Alfa Romeo 159 is fully personalisable, and that also applies to the way you buy and own it, due to a range of options that have been developed for you.

Alfa Romeo Financial Services is a division of Wesbank – A division of First Rand Bank Ltd.

An Authorised Financial Services & Credit Provider NCRCP20.

Tel: 0861 137 137
Fax: 0861 101 833
Email: finance@wesbank.co.za
Hours: Weekdays 8am to 5pm
Saturdays 8am to 12pm

Dealer's stamp

DISCLAIMER: Alfa Romeo products are distributed by Fiat Group Automobiles South Africa (Pty) Ltd. Pictures are for illustrative purposes only and are not necessarily accurate. Fiat Group Automobiles South Africa reserves the right to change specifications and discontinue models and equipment without notice. Service Plan, Warranty Conditions and Roadside Assistance are applicable to South African territory only.

FOR MORE INFORMATION CONTACT YOUR NEAREST ALFA ROMEO DEALER. E & OE.

Part number: 59033044



www.alfaromeo.co.za