



SUBARU

# ASCENT





## **Dream Bigger.**

When you're ready for life's next big adventure, the 2021 Ascent is ready to take you to new heights. It's the largest and most versatile Subaru ever, with three rows and seating for up to eight.<sup>1</sup> It's packed with advanced technologies, from active safety systems to entertainment features. And you'll always drive with confidence, thanks to legendary Subaru quality, durability and reliability.



## Fits a lifetime of memories.

With up to 4,347 litres of passenger space<sup>1</sup> and a multitude of seating options, the three-row Ascent welcomes everyone. The standard second-row bench provides seating for up to eight,<sup>2</sup> while the available second-row captain's chairs give you easy access to the third row while seating up to seven. No matter the configuration, the inside of the Ascent is where the journeys—and the great stories—begin.

### 1 Spacious & Comfortable Cabin

All three rows of the Ascent enjoy generous amounts of space, quality materials, excellent visibility and incredible quietness.

### 2 Rear-seat Climate Controls

There are three separate climate control zones, including air vents in each row. And heated and ventilated front seats,<sup>2</sup> second-row heated seats,<sup>2</sup> and rear-seat climate controls<sup>2</sup> are all available so you can customize the level of comfort in each row.

<sup>1</sup> 4,248 litres with optional power moonroof.

<sup>2</sup> Availability varies by trim level. See your retailer for details.





ASCENT



## Right-sized for your day as well as your destination.

Whatever the size or shape of your journey, the Ascent is ready. It offers nine different seating configurations, thanks in part to its two rows of flat-folding seats. There's also up to 2,449 litres of cargo space<sup>1</sup> and under-floor storage if you need it. And thoughtful details like the power tailgate with lock switch,<sup>2</sup> standard raised roof rails and 19 cup and bottle holders mean the Ascent can take on whatever your day demands.

<sup>1</sup> 2,435 litres with available power moonroof.  
<sup>2</sup> Availability varies by trim level. See your retailer for details.







## "Are we there yet?" Said no one.

Family time is quality time, and the Ascent helps make it exceptional. STARLINK® smartphone integration includes Apple CarPlay®<sup>1</sup> and Android™ Auto<sup>2</sup> functionality and connects you to all your music and apps through a 6.5- or 8-inch touchscreen.<sup>3</sup> The available TomTom®<sup>4</sup>-powered navigation system keeps you on the right path.<sup>3</sup> And the available 792-watt-equivalent Harman Kardon®<sup>5</sup> 14-speaker surround sound system offers a crisp, authentic listening experience.<sup>3</sup>

### 1 SUBARU STARLINK® with Apple CarPlay® and Android™ Auto

Use today's most popular apps with standard Apple CarPlay®<sup>1</sup> and Android™ Auto.<sup>2</sup> Voice recognition capabilities allow for hands-free use, keeping everybody safe while reducing distractions when you're on the road.

### 2 180-Degree Front View Monitor<sup>3</sup>

Get a full, 180-degree view in front of the Ascent when you're parking close to an obstruction or attempting to pull out into an obscured intersection.

### 3 Multifunction Display<sup>3</sup>

Located conveniently in your sight line, important car vitals appear at the touch of a button. The display also shows your environmental performance and efficiency, and it even lets you compare efficiency between different trips.

### 4 Rearview Camera

Safely and conveniently manoeuvre the Ascent in tight spaces with ease. It features a super-wide view for better visibility, and guidelines assist you with parking.



1 Apple CarPlay® is a registered trademark of Apple Inc.

2 Android™ is a trademark of Google LLC.

3 Availability varies by trim level. See your retailer for details.

4 TomTom® is a registered trademark of TomTom International B.V.

5 Harman Kardon® is a registered trademark of Harman International Industries, Inc.



**Your dream destination  
is more real than ever.**

The Ascent is more than capable of getting big groups to the bigger outdoors, thanks to a combination of proven core technologies and the latest in all-road/all-weather performance systems. It features a Direct-Injection Turbocharged (DIT) 2.4L SUBARU BOXER® engine paired with our legendary Subaru Symmetrical Full-Time All-Wheel Drive. The Subaru Global Platform (SGP) uses high-strength steel to offer excellent crash protection along with a quiet, comfortable ride. And because the Ascent can tow up to 2,270 kg,<sup>1</sup> has 220 mm of ground clearance and features X-MODE® with Hill Descent Control, you have more destination options to consider.



#### **X-MODE® with Hill Descent Control**

With a push of a button, X-MODE® takes control of the engine, transmission, AWD, brakes and other components to help you safely navigate through rough terrain and slippery surfaces with maximum confidence. For challenging descents, Hill Descent Control enhances confidence down steep hills by providing constant, controlled momentum so the driver can focus more on steering and less on braking.

1 Towing capacity varies by trim level. Trailer brakes may be required. See your retailer for details.



## An extra set of eyes every time you drive.

Every Ascent includes standard EyeSight® Driver Assist Technology.<sup>1</sup>

EyeSight® Driver Assist Technology integrates multiple safety and convenience features so you'll always feel comfortable and protected, wherever you go. EyeSight® gives you a virtual second pair of eyes on the road that can warn you of potential danger ahead and even apply the brakes if necessary. It's a vigilant safety feature that gives peace of mind to every drive. Once you experience it, driving will never be the same.

### Pre-Collision Braking<sup>1</sup>

A driver ahead unexpectedly hits the brakes or cuts you off. EyeSight® warns you, applies brakes and, at lower speeds, can even help you stop your Ascent.



### Lane Departure and Sway Warning with Lane Keep Assist<sup>1</sup>

You accidentally drift to the edge of your lane and begin to cross into another. EyeSight® watches for lane markers and chimes to warn you, and it can even apply gentle steering inputs to help keep you in your lane.



### Adaptive Cruise Control with Lane Centring Assist<sup>1</sup>

Automatically keeps you centred in your lane, at a safe distance behind the car in front of you—even in traffic and around curves.



### Pre-Collision Throttle Management<sup>1</sup>

Can reduce your engine power to help give you more time to react and to help minimize the possible impact force and frontal impact damage.

<sup>1</sup> EyeSight® is a driver assist technology, which may not operate optimally under all driving conditions. The driver is always responsible for safe and attentive driving. System effectiveness depends on many factors such as vehicle maintenance, weather and road conditions. The Pre-Collision Braking System is designed to provide automatic braking that either prevents a collision or reduces the severity of a frontal impact. Pre-Collision Throttle Management is designed to reduce acceleration and minimize the severity of certain frontal impacts. Lane Centring Assist is designed to assist the driver and is not a substitute for safe and attentive driving. Lane centring function operates only when used in conjunction with Adaptive Cruise Control. The Lane Departure and Sway Warning, and Lane Keep Assist operate only when the lane markings are visible, and its effectiveness depends on many factors. See Owner's Manual for complete details on system operation and limitations.



#### **Blind-Spot Detection**

Using radar sensors, Blind-Spot Detection<sup>1,2</sup> warns you with a visual indicator on your side mirror if the system detects a vehicle in your blind spot. Another feature of this system, Lane Change Assist, alerts you with a flashing indicator on your side mirror if it senses a vehicle approaching at a higher speed in a neighbouring lane.



#### **Rear Cross-Traffic Alert**

Rear Cross-Traffic Alert<sup>1,2</sup> uses radar sensors to help warn you of traffic approaching from the side as you are backing up, utilizing a flashing visual indicator on your side mirror and Rearview Camera display as well as an audible warning.



## The road may waver, but not your priorities.

### Safety that meets the highest expectations.

We know what's most important to you when you drive, and that's why safety is at the top of our minds, too. The Ascent offers some of the most advanced active safety systems on the market. Rain-sensing Wipers<sup>1</sup> can automatically turn on and adjust to the necessary speed and interval. The Smart Rear-View Mirror<sup>1</sup> helps you see what's behind you when your view is blocked. The 180-Degree Front View Monitor offers enhanced visibility when pulling out into blind intersections or into tight parking spots.<sup>1</sup> And standard LED Steering Responsive Headlights with High Beam Assist help make nighttime driving even safer.

1 Availability varies by trim level. See your retailer for details. 2 Blind-Spot Detection, Lane Change Assist and Rear Cross-Traffic Alert are systems designed to assist the driver by monitoring the rear and side areas of the vehicle during a lane change or reversing and are not a substitute for safe and attentive driving. 3 The Reverse Automatic Braking System is not a substitute for safe and attentive driving. System effectiveness depends on many factors, such as vehicle maintenance, weather and road conditions. Always exercise caution and use vehicle mirrors and the Rearview Camera when backing up. See Owner's Manual for complete details on system operation and limitations. 4 Activation with subscription required.



#### Reverse Automatic Braking

Reverse Automatic Braking<sup>1,3</sup> can detect objects directly behind your vehicle when backing up at a low speed and can help bring the Ascent to a stop should an object be detected within its range and the driver fails to act. There's also the Rearview Camera to help you keep an eye out.



#### SUBARU STARLINK® Connected Services

The Ascent features next-generation SUBARU STARLINK® Connected Services technology,<sup>1,4</sup> bringing you added safety, security and convenience. It can alert a first responder in an emergency, help police locate your vehicle if it's stolen and more. And to get you started, new Ascent drivers enjoy a free three-year SUBARU STARLINK® Connected Services subscription, which includes Advanced Automatic Collision Notification, Enhanced Roadside Assistance, SOS Emergency Assistance and more.

## Passive Safety

### Ring-shaped Reinforcement Frame

The Ring-shaped Reinforcement Frame strengthens the passenger cabin's roof, doors, pillars and floor. This design helps divert and dissipate impact energy away from the occupants in a collision by use of high-strength materials and strategic placements. While making it stronger with increased torsional rigidity, the overall frame is still lightweight.



Actual model trim may vary.

## Active Safety

### Visibility

With a commanding perspective and front and rear visibility at the top of its class, the Ascent keeps the driver aware and at ease on narrow roads and in tight spaces. Blind spots are kept to a minimum with well-positioned A-pillars and integrated partition windows. The side mirrors have also been placed onto the door panels, creating a remarkably open field of view.



### Seats, Seatbelts and SRS<sup>1</sup> Airbags

Standard on the Ascent are front SRS<sup>1</sup> airbags, plus a driver's knee SRS<sup>1</sup> airbag as well as front-side and curtain SRS<sup>1</sup> airbags. Height-adjustable front seatbelts feature pretensioners to hold passengers firmly in place as well as load limiters that ease peak forces to the chest. A new passenger seatbelt indicator and chime lets you know which passengers are not yet buckled. In a rear collision, front seats utilize rigid frames, firm headrests and such details as energy-absorbing mounting of the inner seat springs—all to help reduce the chance of whiplash.

### Pedestrian Protection

Shock-absorbing space within the vehicle helps reduce pedestrian injury, as do an energy-absorbing front bumper and a specially designed area around the windshield wipers.

### Cabin-protecting Layout

Every Subaru goes above and beyond common practice when it comes to your safety. In the event of a head-on collision, your Ascent's SUBARU BOXER<sup>®</sup> engine and gearbox are designed to slide under the vehicle, absorbing crash force in the process.



### Vehicle Dynamics Control

Vehicle Dynamics Control monitors and analyzes whether the vehicle is following the driver's intended course via an array of sensors. If a tire slips or a high-speed turn causes the vehicle to veer off its intended path, the AWD torque distribution, engine output and brakes at each wheel are adjusted to assist in keeping the vehicle on course.

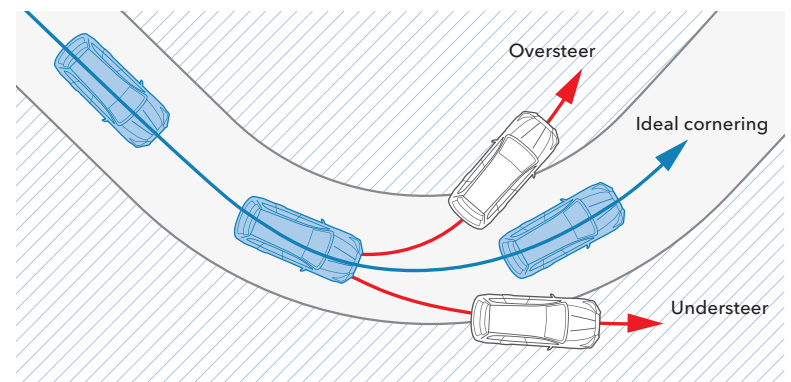

### Braking System

The standard 4-wheel disc Anti-lock Braking System (ABS) with Electronic Brake-force Distribution helps redistribute braking power where you need it among all four wheels, while the Brake Assist and Brake Override systems help provide enhanced control in emergency braking situations. There's also the Auto Vehicle Hold system, which helps prevent rollback when starting from a stop on any slope.

<sup>1</sup> SRS: Supplemental Restraint System. Effective when used in conjunction with seatbelts.

# 2021 Ascent | Features & Dimensions

LED Steering Responsive Headlights (SRH)



Panoramic Glass Sunroof<sup>1</sup>



SUBARU STARLINK<sup>®</sup> with Apple CarPlay<sup>®2</sup> and Android<sup>™</sup> Auto<sup>3</sup>



Third-row USB Ports<sup>4</sup>



Second-row Automatic Climate Control<sup>1</sup>



Ventilated Front Seats<sup>5</sup>

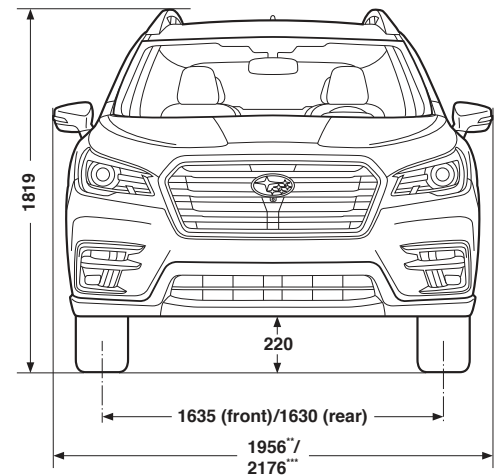
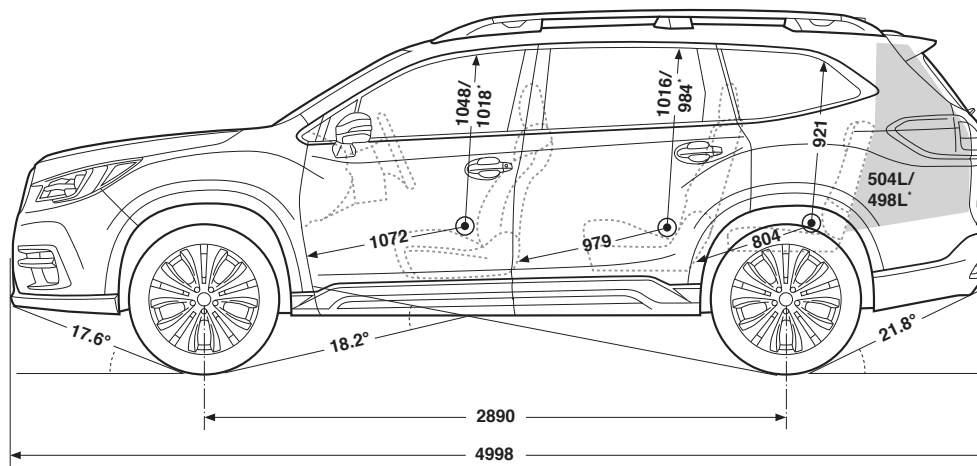

Measurements in millimetres unless specified.

\* With available Panoramic Glass Sunroof.

\*\* With mirrors folded.

\*\*\* With mirrors. 2187 with mirrors with integrated turn signals.

**For a detailed list of specifications, features, accessories and model comparisons, please visit [Subaru.ca](http://Subaru.ca) or your nearest authorized Subaru Retailer.**

1 Not available on Convenience trim. 2 Apple CarPlay<sup>®</sup> is a registered trademark of Apple Inc. 3 Android<sup>™</sup> is a trademark of Google LLC. 4 Limited and Premier models only. Not available on Convenience and Touring trims. 5 Premier models only. Not available on Convenience, Touring and Limited trims. 6 EyeSight<sup>®</sup> is a driver assist technology, which may not operate optimally under all driving conditions. The driver is always responsible for safe and attentive driving. System effectiveness depends on many factors such as vehicle maintenance, weather and road conditions. See Owner's Manual for complete details on system operation and limitations. 7 Compatible smartphone and applications required. Data provided by smartphone is displayed on the audio system screen. Some provinces prohibit the operation of handheld electronic devices while operating a vehicle. Smartphone apps should be launched only when vehicle is safely parked. Aha<sup>™</sup> is a trademark of Harman International Industries, Inc. Your wireless carrier's rates may apply. 8 Apple<sup>®</sup> and iPod<sup>®</sup> are registered trademarks of Apple Inc. 9 Bluetooth<sup>®</sup> is a registered trademark of Bluetooth SIG, Inc., America. 10 Activation and required monthly subscription sold separately. Includes 3-month trial subscription. See your retailer. 11 The Reverse Automatic Braking System is not a substitute for safe and attentive driving. System effectiveness depends on many factors, such as vehicle maintenance, vehicle speed, weather and road conditions. Always exercise caution and use vehicle mirrors and the Rearview Camera when backing up. See Owner's Manual for complete details on system operation and limitations. 12 Blind-Spot Detection, Lane Change Assist and Rear Cross-Traffic Alert are systems designed to assist the driver by monitoring the rear and side areas of the vehicle during a lane change or reversing and are not a substitute for safe and attentive driving. 13 Activation with subscription required. 14 Harman Kardon<sup>®</sup> is a registered trademark of Harman International Industries, Inc.



## Convenience

- 260-hp 2.4-litre 4-cylinder Direct-Injection Turbocharged (DIT) SUBARU BOXER® engine
- Subaru Symmetrical Full-Time All-Wheel Drive with X-MODE® with Hill Descent Control
- Lineartronic® CVT with Active Torque Vectoring
- EyeSight® Driver Assist Technology<sup>4</sup>
- LED Steering Responsive Headlights (SRH) with High Beam Assist (HBA)
- 18-inch aluminum-alloy wheels with silver finish
- Raised roof rails
- Privacy glass
- 8-way power-adjustable driver's seat
- Heated front seats
- Second-row bench seat (8 passengers)
- Cloth upholstery
- Rear Seat Reminder
- Auto-up/down driver's and front-passenger's power windows
- 4 USB ports
- Tri-zone automatic climate control system
- Cabin-view mirror
- 19 cup and bottle holders
- Front and rear passenger seatbelt warning light and chime
- 6.5-inch infotainment system: AM/FM/CD/MP3/WMA audio system with high-resolution touchscreen display, Apple CarPlay,<sup>®2</sup> Android™ Auto,<sup>3</sup> STARLINK® smartphone integration (including Aha™ radio),<sup>7</sup> 6 speakers, dual USB port/iPod<sup>®8</sup> control, auxiliary audio input, steering wheel-integrated controls, Bluetooth<sup>®9</sup> mobile phone connectivity with voice activation and Bluetooth<sup>®9</sup> streaming audio, SiriusXM® Satellite Radio<sup>10</sup> and SiriusXM® Travel Link<sup>®10</sup>



## Limited

### Includes Touring key features and adds/upgrades:

- 20-inch aluminum-alloy wheels in dark grey with machine finish
- Lower door cladding with chrome accents
- Body-colour side mirrors with integrated turn signals
- Leather-trimmed upholstery
- 10-way driver/4-way front-passenger power seats
- Two-position driver's seat memory
- Driver's seat adjustable thigh support
- Heated steering wheel and outboard rear seats
- Harman Kardon<sup>®14</sup> 14-speaker surround sound system
- 6.3-inch colour multifunction display
- Second-row retractable sunshades
- 6 USB ports
- 8-inch infotainment system with navigation: AM/FM/CD/MP3/WMA audio system with high-resolution capacitive touchscreen display with GPS navigation system, Apple CarPlay,<sup>®2</sup> Android™ Auto,<sup>3</sup> STARLINK® smartphone integration (including Aha™ radio),<sup>7</sup> dual USB port/iPod<sup>®8</sup> control, auxiliary audio input, SMS text messaging capability, Bluetooth<sup>®9</sup> mobile phone connectivity with voice activation and Bluetooth<sup>®9</sup> streaming audio, SiriusXM® Satellite Radio,<sup>10</sup> SiriusXM® Traffic<sup>10</sup> and SiriusXM® Travel Link<sup>®10</sup>
- Optional second-row captain's chairs (7 passengers)



## Touring

### Includes Convenience key features and adds/upgrades:

- 2,270-kg towing capacity
- 18-inch aluminum-alloy wheels in grey with machine finish
- Power tilting and sliding panoramic glass sunroof
- Body-colour side mirrors with integrated turn signals
- Power tailgate with lock switch
- LED fog lights
- Spill-resistant premium cloth upholstery
- Leather-wrapped steering wheel and shift lever handle
- Proximity key with Push-button Start
- Reverse Automatic Braking<sup>11</sup>
- Blind-Spot Detection with Lane Change Assist and Rear Cross-Traffic Alert<sup>12</sup>
- Second-row Automatic Climate Control
- One-touch interior lighting
- 8-inch infotainment system: AM/FM/CD/MP3/WMA audio system with high-resolution touchscreen display, Apple CarPlay,<sup>®2</sup> Android™ Auto,<sup>3</sup> STARLINK® smartphone integration (including Aha™ radio),<sup>7</sup> 6 speakers, dual USB port/iPod<sup>®8</sup> control, auxiliary audio input, steering wheel-integrated controls, Bluetooth<sup>®9</sup> mobile phone connectivity with voice activation and Bluetooth<sup>®9</sup> streaming audio, SiriusXM® Satellite Radio<sup>10</sup> and SiriusXM® Travel Link<sup>®10</sup>
- SUBARU STARLINK® Connected Services (free 3-year trial subscription included)<sup>13</sup>
- Optional second-row captain's chairs (7 passengers)



## Premier

### Includes Limited key features and adds/upgrades:

- Second-row captain's chairs (7 passengers)
- Heated and ventilated front seats
- Woodgrain-patterned matte finish accent trim
- 120-volt AC power outlet
- Smart Rear-View Mirror
- 180-Degree Front View Monitor
- Rain-sensing wipers
- Gloss black grille
- Power-folding satin chrome side mirrors with integrated turn signals
- Chrome door handles
- Brown or Black Leather upholstery
- Upgraded leather steering wheel

## 2021 Ascent | Colours

### Exterior Colours

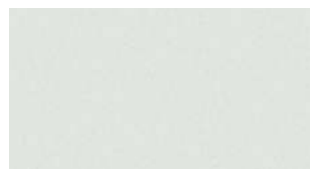

Crystal White Pearl

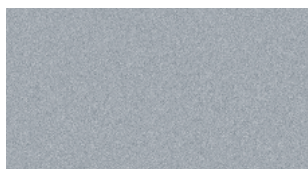

Ice Silver Metallic

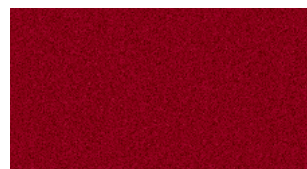

Crimson Red Pearl



Brilliant Bronze Metallic



Abyss Blue Pearl

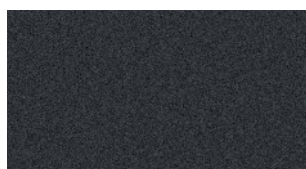

Magnetite Grey Metallic

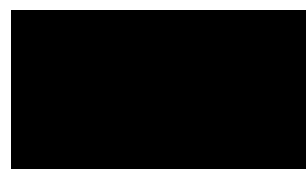

Crystal Black Silica

### Seat Material

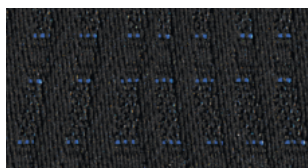

Black Cloth (BC)



Black Premium Cloth (BPC)



Black Leather (BL)



Ivory Leather (IL)



Brown Leather (BRL)

Colour Combinations	Convenience	Touring	Limited	Premier
Crystal White Pearl	BC	BPC	BL	BL or BRL
Ice Silver Metallic	BC	BPC	BL	BL or BRL
Crimson Red Pearl	BC	BPC	BL	BL
Brilliant Bronze Metallic	–	BPC	BL or IL	BL
Abyss Blue Pearl	–	BPC	BL or IL	BL or BRL
Magnetite Grey Metallic	BC	BPC	BL	BL or BRL
Crystal Black Silica	BC	BPC	BL	BL or BRL



## Subaru Warranties

Every Subaru vehicle is designed and built to offer our customers the highest possible level of quality and reliability. We are proud of our vehicles and proud to stand behind them with a comprehensive warranty. For 2021 model-year vehicles, the warranty on all Subaru vehicles consists of the following:

**New Vehicle Limited Warranty (36 month/60,000 km)** – Covers basic and major components for 36 months or 60,000 km.

**Major Component Limited Warranty (60 month/100,000 km)** – Extends coverage of major components (more than just powertrain) up to 60 months or 100,000 km.

**Surface Corrosion Limited Warranty (36 month/60,000 km)** – Covers surface corrosion to visible painted body panels for 36 months or 60,000 km.

**Anti-Perforation Limited Warranty (60 month/unlimited km)** – Covers perforation due to corrosion to body sheet metal panels for 60 months, regardless of kilometres.

**Emission Control System Limited Warranty** – Covers some emissions components for 36 months or 60,000 km and the major parts of the emission control system for 96 months or 130,000 km.

**Parts and Accessories Limited Warranty** – Covers Subaru parts and accessories installed by the retailer prior to retail delivery of the vehicle for 36 months or 60,000 km, and Subaru parts and accessories installed by the retailer after the retail delivery of the vehicle for 12 months or 20,000 km from the date of the installation.

The above information is an overview of warranty coverage and is not a warranty statement. If you wish to see more details regarding Subaru warranties, please refer to your Subaru warranty booklet, contact your local retailer or visit our Web site at [subaru.ca](http://subaru.ca).

## Subaru 360 C.A.R.E. Program (36 months/unlimited km)

Access to dedicated Subaru 360 C.A.R.E. (Customer Assistance for Roadside Emergencies) Roadside Assistance Services, which includes access to 1,000 CAA and AAA offices throughout Canada and the United States. In addition to towing, coverage also includes Fuel Delivery, Battery Boost, Flat Tire Service, Lock-Out Service, Trip Accident & Mechanical Breakdown Assistance Service, Winching and Extrication Service, Personalized Trip Planning and Routing, Theft and Hit-and-Run Reward, and Arrest Bond Certificate.

The above information is an overview of services. If you wish to see more details regarding Subaru 360 C.A.R.E., please visit our Web site at [subaru.ca](http://subaru.ca).

## Subaru Protection Plan

As a Subaru owner, you have expectations for a pleasurable, trouble-free ownership experience – now and into the future. Once your 36-month/60,000-km New Vehicle Limited Warranty period ends,<sup>1</sup> our Subaru Protection Plan (SPP) – the only vehicle service contract endorsed by Subaru Canada for Subaru vehicles – can prolong your hassle-free ownership experience with three levels of extended service contract coverage tailored to your needs: Powertrain Protection; Major Protection; or Complete Protection (best level of coverage to complement the 60-month/100,000-km Major Component Limited Warranty). SPP offers comprehensive mechanical and electrical coverage and a number of additional features and benefits, such as Roadside Assistance and Alternate Transportation, for up to 7 years or 160,000 kilometres from your vehicle's in-service date. Whether your vehicle is purchased or leased, SPP protects you and your investment. Be sure to ask your retailer for details or visit [subaru.ca](http://subaru.ca).

<sup>1</sup> If you already own a Subaru vehicle and it is still within the 36-month/60,000-km New Vehicle Limited Warranty period, you are still eligible for SPP.

Subaru vehicles are uniquely designed to get out there more and to leave less behind. We build our vehicles for maximum longevity, because more time spent on the road equals less time spent in junkyards and landfills. 98% of Subaru vehicles sold in Canada over the last 10 years are still on the road today.<sup>1</sup> You'll also find very little waste created in the production of a Subaru. Many of our vehicles are built in the Subaru of Indiana Automotive, Inc., (SIA) factory, which was the first manufacturing facility in the U.S. to achieve zero-landfill status. Other Subaru facilities around the world now achieve similar goals in helping to preserve the environment. Respect for our surroundings is yet another way that Subaru vehicles help to build driver confidence for the road ahead.

<sup>1</sup> Based on IHS Markit, Canadian Vehicles in Operation as of June 30, 2019, for Model Years 2010 to 2019 vs. Total New Registrations of those vehicles.



**For a detailed list of specifications, features, accessories and model comparisons, please visit [Subaru.ca](http://Subaru.ca) or your nearest authorized Subaru Retailer.**

The Supplemental Restraint System (SRS airbags) affords the driver and passenger additional protection in some collisions. This system provides supplemental protection only, and seatbelts must be worn in order to avoid injuries to out-of-position occupants upon airbag deployment. The combination of SRS and seatbelts provides the best protection in a serious accident. All illustrations, specifications, features and photographs contained in this brochure are based on product information available at the time of its printing and may not be completely accurate following its publication. Colours shown may vary due to reproduction variations in the printing process, and some vehicle parts cannot be shown in certain photographs. Subaru Canada, Inc. reserves the right to discontinue or make changes at any time, without notice or incurring obligations, to colours, materials, equipment, accessories, features, specifications and models, or to change their prices. Some models shown may be from international markets and are not available in Canada; may be shown with equipment or accessories that are optional (at extra cost) or available only in certain combinations; or may be subject to product delays or not be available in Canada. Please visit [subaru.ca](http://subaru.ca) for the latest information and specifications. For complete details on product updates and warranties, please contact your Subaru retailer. Ascent, BRZ, Crosstrek, Forester, EyeSight, Impreza, Legacy, Outback, WRX, STI, Lineartronic, X-MODE, STARLINK, Subaru and SUBARU BOXER are registered trademarks of SUBARU CORPORATION. Aha™ is a trademark of Harman International Industries, Inc. Harman Kardon® is a registered trademark of Harman International Industries, Inc. Android™ is a trademark of Google LLC. Apple CarPlay® and iPod® are registered trademarks of Apple Inc. Bluetooth® is a registered trademark of Bluetooth SIG, Inc., America. TomTom® is a registered trademark of TomTom International B.V. "SiriusXM®", "SiriusXM® Traffic," "SiriusXM® Travel Link®" and the SiriusXM logo, channel names and logos are trademarks of SiriusXM Radio Inc. and are used under licence by Sirius XM Canada Inc. Subscriptions to SiriusXM Canada are subject to the SiriusXM Canada Customer Agreement and other terms and conditions. Printed in Canada. © 2020 Subaru Canada, Inc. 2021 model year.



Environmental Management System  
(EMS) ISO 14001:2015 certified by SGS

This booklet was printed on FSC® certified paper and contains 55% recycled fibre. It is chlorine-free, recyclable and biodegradable. FSC® (Forest Stewardship Council®) is an international organization that brings people together to find solutions that promote responsible management of the world's forests. This booklet was also produced using a "GREEN" printing process, which includes vegetable-based inks that leave no harmful residue. Please recycle.



[subaru.ca](http://subaru.ca)

**SUBARU CANADA, INC.**

560 Suffolk Court, Mississauga, ON, L5R 4J7