

2022 FORD POLICE & SPECIAL SERVICE VEHICLES



FORD FLEET

A FORCE TO BE RECKONED WITH



A forceful high five for law enforcement:

- The Police Interceptor Utility is the best-selling police vehicle in America¹
- The Police Interceptor Utility Hybrid AWD is the only pursuit-rated hybrid police utility
- All-New 2021 F-150 Police Responder – the only pursuit-rated pickup truck
- F-150 SSV – available with the breakthrough 3.5L PowerBoost™ hybrid engine
- Expedition/Expedition MAX SSV – the largest Ford SUV is outfitted in the name of Special Service
- Transit PTV – Built Ford Tough® Prisoner Transport Vehicle is available with AWD capability

Vehicle imagery throughout this brochure may be computer-generated and may include available and aftermarket equipment.

TABLE OF CONTENTS

FULL FORD POLICE LINEUP

2022 Ford Police Interceptor® Utility	2
Hybrid Savings Calculator	5
12.1" Integrated Computer Screen	6
Police Perimeter Alert	8
Ford Telematics™ for Law Enforcement	10
All-New 2021 Ford F-150® Police Responder®	12
Special Service Vehicles	14
2021 Ford F-150 SSV	16
2021 Ford Expedition®/Expedition MAX SSV	17
2022 Ford Transit® PTV	18
Supporting Vehicles	19

POLICE INTERCEPTOR UTILITY DNA

Safety & Security	20
Heavy-Duty Durability	22
Total Performance	24
Purpose-Built	26
Upfit-Friendly	28

DETAILED VEHICLE SPECS

2022 Police Interceptor Utility	30
All-New 2021 F-150 Police Responder	34
2021 F-150 SSV	36
2021 Expedition/Expedition MAX SSV	38
2022 Transit PTV	40

UPFIT SOLUTIONS & OPTIONAL FEATURES

Police Interceptor Utility Lighting Solutions	42
Factory-Installed Upfit Packages	44
Select Factory-Installed Upfit Options	46
Vehicle Special Order (VSO) Paint, Lighting & Equipment	47

CUSTOMER SERVICE

Essential Resources	48
Elite Police Advisory Board (PAB)	49

¹Based on IHS Markit new vehicle registration data limited to government entities and POL and SSV trim vehicles for full year 2020.

2022 FORD POLICE INTERCEPTOR® UTILITY



POLICE INTERCEPTOR

NO-TRADE-OFFS HYBRID – STANDARD

The Ford Police Interceptor Utility Hybrid AWD is the only pursuit-rated hybrid SUV: fortified with standard full-time Intelligent AWD, an amazing 3.3L V6 hybrid engine and a 10-speed transmission.

Potential fuel savings: The hybrid powertrain offers significant potential reductions in fuel use when decreased engine idle times and an EPA-estimated rating of 23 city/24 combined miles per gallon¹ are factored in, potentially saving \$3,509 per vehicle per year.²

Michigan State Police and Los Angeles County Sheriff's Department conduct rigorous evaluations of police vehicles each year. Reports from those evaluations, including acceleration figures, lap times and top-speed numbers, can be found on their websites.³

When equipped with the 3.0L EcoBoost® engine, the Police Interceptor Utility outperformed all police competitors – including V8-equipped models – that participated in official Michigan State Police testing.⁴

Assembled in the U.S.A.⁵ with duty-ready technology (like the available 12.1" Integrated Computer Screen [ICS]), the Police Interceptor Utility is designed and engineered in Dearborn and assembled in Chicago: Its abundance of standard features means there's a lot of potential value for taxpayers' money. The built-in Ford modem and complimentary 2-year Ford Telematics™ subscription⁶ make for timely cloud-based, manufacturer-grade insights to help optimize running costs and improve asset utilization. Bluetooth® wireless connectivity allows for pass-through voice commands to mobile devices at the touch of a button.

Exceptional safety: The Police Interceptor Utility is 75-mph rear-impact crash tested.⁷ It proudly proclaims to be the only vehicle in the world engineered to meet this test.

Note: See additional Police Interceptor Utility DNA on pages 20-29.



¹Actual mileage will vary. 2021 Ford Explorer® Police Interceptor Utility 3.3L Hybrid 4WD. ²Calculation based on comparison with the previous-generation 3.7L V6 Police Interceptor Utility and an example fuel price of \$2.75 per gallon. (See computations on next page.) ³www.michigan.gov/msp and www.lasd.org. ⁴Based on the 0-60 mph, 0-80 mph, 0-100 mph, top speed and vehicle dynamics lap time testing results from the Model Year 2021 Michigan State Police Vehicle Evaluation Program. ⁵Assembled in the U.S.A. with domestic and foreign parts. ⁶2-year subscription for Ford Telematics starts on vehicle warranty start date. Subscription features may be limited. Factors causing this limitation may include, but are not limited to, issues related to cellular coverage, carrier outages and carrier network service interruptions. Complimentary service ends after 2 years. ⁷The full-size spare tire secured in the factory location is necessary to achieve police-rated 75-mph rear-impact crash-test performance attributes.

REPEAT: A NO-TRADE-OFFS HYBRID

Innovative engineering and design of the hybrid system helps ensure an abundance of versatile passenger/cargo room: Total interior volume is 170.0 cu. ft. It offers a full 3.5 cu. ft. more space than the previous-generation Ford Police Interceptor® Utility. Passenger volume is a vast 118.0 cu. ft., and cargo volume behind the 2nd row is an expansive 52.0 cu. ft. Spaciousness originates with the strategic placement of the hybrid's battery pack below the floor.

On the standard Ford Police Interceptor Utility, the electric motor's high-voltage lithium-ion battery pack utilizes an advanced liquid heating and cooling system. This integrated system helps keep the pack's components operating at optimum temperature. Ready and rarin' to go, the battery pack's approximately 280 volts (with 35kW peak discharge power) are more than capable of energizing the electric motor. The battery pack provides full power to on-board equipment – from emergency lights and radios, to laptops and printers, plus the cabin's AC and heat – even when the gas engine is off during idle. Remain calm, cool or warm, and collected.

Cold cranking power – to start the longitudinally mounted 3.3L direct-injection hybrid V6 – is assured with the H7 AGM (absorbent glass mat) 12V battery. It has an impressive 800-CCA/80-amp rating. Or optionally step up to the H8 AGM version with an 850-CCA/92-amp starting power. To help support police upfit and agency electronics, a high-output 220-amp DC/DC converter is put into action in place of an alternator.

A police-calibrated high-performance Regenerative Braking System means that when braking, the Police Interceptor's lithium-ion hybrid battery is charging. Regenerative technology recaptures energy from vehicle motion by turning the electric motor into a generator, converting braking energy to electricity, and storing it in the lithium-ion battery pack for later use.



POWERFUL HYBRID SAVINGS

RESPONSIVE TO YOUR RIGHT FOOT AND, JUST AS IMPORTANT, YOUR BUDGET

The Police Interceptor Utility – that comes standard as a hybrid electric vehicle (HEV) with AWD – offers significant potential fuel savings. Its lithium-ion hybrid battery can provide added benefits when considering the unique idling demands of day-to-day police use.

While driving. Police Interceptor Utility (standard HEV AWD) fuel economy compares favorably against the past-generation Police Interceptor Utility (3.7L AWD).

While idling. Even when not in motion, police vehicles must constantly keep their engines running to power electrical equipment. Ford data shows that police vehicles spend approximately 61% of each shift at engine idle: This equates to roughly 4.9 hours of every 8-hour shift. The Police Interceptor Utility (standard HEV AWD) reduces engine idle time by powering the high electrical loads of a police vehicle with its lithium-ion battery. So the engine runs less – intermittently called upon to top off the battery.

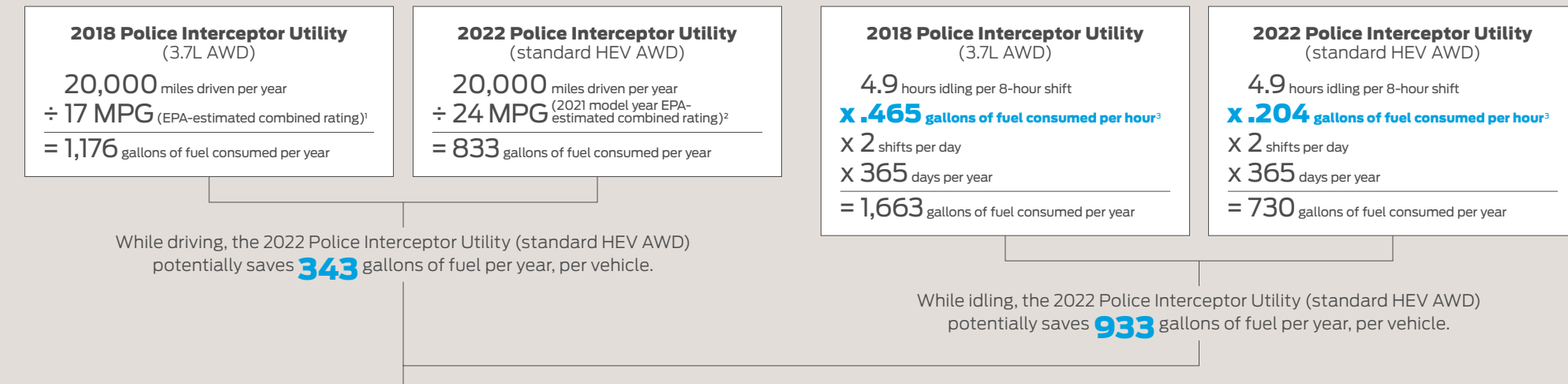

In summary, the 2022 Police Interceptor Utility (standard HEV AWD) potentially saves:

An estimated **343** gallons of fuel per year while driving.

(+) An estimated **933** gallons per year saved while vehicle is at idle.

(=) An estimated **1,276** gallons saved per year, total.

That's **\$3,509** in potential savings per year, per vehicle. (Assuming an example gas price of \$2.75 per gallon.) Projecting to 4-, 5- or 6-year ownership terms, savings could grow to as high as \$34,452 at \$4.50 per gallon (see chart at right).

Additionally, there's a potential **25,560 lbs.** of CO₂ output⁴ reduced per year, per vehicle.

Visit fordpoliceinterceptor.com to calculate your own agency's potential savings.

2022 Police Interceptor Utility (standard HEV AWD)			
Potential Total Savings at Varying Gas Prices and Terms			
	4 Years	5 Years	6 Years
\$3.00/gallon	\$15,312	\$19,140	\$22,968
\$3.50/gallon	\$17,864	\$22,330	\$26,796
\$4.00/gallon	\$20,416	\$25,520	\$30,624
\$4.50/gallon	\$22,968	\$28,710	\$34,452

¹2018 MY EPA-estimated rating of 15 city/20 hwy/17 combined mpg, 3.7L AWD. Actual mileage will vary. ²2021 MY EPA-estimated combined rating of 24 mpg. Actual mileage will vary. ³Idle Fuel Consumption estimates are based on fuel flow measurements taken during 2 hours of continuous idling. Vehicles were driven for 18 miles at highway speeds prior to idling. Idle testing was conducted in an indoor facility at 73°F. The following vehicle accessories were activated during the test: Climate Control A/C, set to full cool condition; Vehicle Audio System, set to 30% of maximum volume. An electrical power draw load box drawing 32 amps was also connected to each vehicle's 12-volt battery to simulate the following estimated Police accessory loads: Emergency Lights (est. 25 amps); Laptop Computer (est. 3 amps); Police Radio (est. 4 amps). Additional testing details are available at ford.to/2H9qBEf. ⁴Burning a gallon of E10 ethanol fuel produces about 17.68 pounds of CO₂ emitted from the fossil fuel content, according to data provided by the U.S. Energy Information Administration (<http://ford.to/eiareport>).

12.1" INTEGRATED COMPUTER SCREEN



This cabin?

or



This cabin!



CUTTING THE CLUTTER

Add this available factory-installed, factory-warranted¹ Integrated Computer Screen (ICS) for the freedom to stash laptops in the cargo bay, where they can be connected directly to the ICS system. Cable hookup is easy, and it helps ensure utmost security and speed. No special software is required for operation.

Centrally located, the substantial 12.1" touchscreen mirrors the laptop display and potentially eliminates the need for a standalone keyboard. Vehicle audio controls are accessible via the ICS unit. And SYNC[®] 3² voice-activated technology is included.

In addition to a built-in computer screen, you're fortified with the following associated hardware:

- One (1) Audio Video Extender (AVX) box — includes one (1) HDMI cable and one (1) USB cable
- Two (2) AVX communication cables
- Three (3) USB system cables

Equipped with the conveniently placed 12.1" ICS, perform daily duties in a neat, streamlined manner. Simply select Order Code 47E on your next Ford Police Interceptor[®] Utility order.

KEEPING A SHARP LOOKOUT

Enhanced situational awareness: The available Police Perimeter Alert¹ utilizes Blind Spot Information System sensors for approximately 270-degree monitoring outside of the vehicle. It features a vivid visual display in the instrument-panel cluster that can show moving objects, the motion trail, and even the potential threat level.

Nearby movement is analyzed to determine potentially threatening behavior. When such motion is detected, the system automatically activates the rear camera, sounds a chime, rolls up any lowered windows and locks the doors. The alerted officer can then monitor the situation.

Note: Exclusive to the Ford Police Interceptor® Utility.



FORD TELEMATICS™ FOR LAW ENFORCEMENT



TAKING IT TO THE NEXT LEVEL

Increase operational effectiveness with the Ford engineered integrated modem that's standard on the Ford Police Interceptor® Utility and Ford F-150® Police Responder.® A plug-in device is available to retrofit most recent Ford vehicles already in service.

The modem and plug-in device are cloud-connected gateways to Ford Telematics for law enforcement. This simple-to-use, yet powerful software tool delivers manufacturer-grade information, insights and solutions. An easy-to-use interface enables management of the fleet in real-time for quick assessments of where to take action.

Get more time to get back to business with Ford Telematics Essentials. Utilize easy Vehicle Health Insights on demand, dealer service reminders (available Summer 2021), remote lock/unlock capability (available Summer 2021) and a Software Update Manager (available Winter 2021) to help you maximize uptime.

Improve asset utilization with Ford Telematics. Use GPS tracking and geofencing capabilities to help keep apprised of fleet vehicles.

Maximize vehicle uptime with Ford Telematics. Receive proactive notifications – including Vehicle Health Alerts and service reminders – to help plan ahead.

Help optimize running costs with Ford Telematics. Monitor fuel consumption; not only to identify areas of waste, but the causes too.

Improve driver behavior with Ford Telematics. A range of valuable insights into driver performance can lead to coaching opportunities to help increase efficiency and improve compliance.

Note: A complimentary 2-year subscription to Ford Telematics for law enforcement¹ comes standard on the Police Interceptor Utility. For the F-150 Police Responder and all 2021 Ford Police Special Service Vehicles, the modem is standard, and a subscription to Ford Telematics for law enforcement is available.



TORQUE-ON-DEMAND® 4x4 TRANSFER CASE

HOT PURSUIT JUST GOT HOTTER.

The only pursuit-rated pickup truck is more arresting than ever with enhancements that include a higher top speed (120 mph) and a new Torque-On-Demand transfer case that features a “4-Auto” selection on its 4x4 system for exceptional performance and handling, both on- and off-road, as well as “set it and forget it” convenience.

The All-New 2021 Ford F-150® Police Responder® also possesses the greatest torque of any pursuit-rated police vehicle. 500 lb.-ft. of torque and 400 horses are ready for duty. Its 3.5L EcoBoost® V6 is partnered with a 10-speed SelectShift® automatic configured with progressive range select and 5 Selectable Drive Modes.

Upgraded brake calipers, unique brake pad friction material, and unique police engine and transmission calibrations help deliver necessary police-duty performance. The F-150 foundation of the all-new F-150 Police Responder is rock solid, as Ford F-Series® is America’s best-selling truck for 44 years straight!... and counting.

Responding with the best payload capacity² (2,030 lbs.), best standard towing capability³ (7,000 lbs.), and best available towing capacity³ (11,200 lbs.) of any pursuit-rated police vehicle, this powerful pickup is bolstered by the FX4™ Off-Road Package that includes off-road-tuned shock absorbers, underbody skid plates, and an electronic-locking rear axle. A high-strength, military-grade, aluminum-alloy⁴ body and cargo box reinforce its Built Ford Tough® reputation for quality, durability and muscle. Aluminum resists corrosion, and this grade fends off dents and dings; a fully boxed, high-strength-steel frame sets the foundation.

With 131.9 cu. ft. of interior volume – shoulder room, hip room and rear leg room are the most of any pursuit-rated police vehicle. The F-150 Police Responder can comfortably seat 5 – even while wearing body armor and holsters. The driver’s seat is 8-way powered, and both front seats – with reduced bolsters for comfort – are outfitted in heavy-duty dark cloth. Front seat backs have steel intrusion plates. Amenities extend to an available Remote Keyless Entry System that includes 4 key fobs, as well as an available keyed-alike option. Add the new available Interior Work Surface for a flat workspace in the center console area that can slide to either the driver or front-passenger side.

New technology on the F-150 Police Responder includes a police engine idle feature that allows the key to be removed from the vehicle while it still idles. Also inside, now available SYNC® 4 features an 8" touchscreen in the center stack and can include available cloud connectivity as well as wireless Software Updates. A built-in Ford modem allows for the addition of an available Ford Telematics™ subscription for manufacturer-grade data and insights into each vehicle’s operation. Available Pre-Collision Assist with Automatic Emergency Braking includes a temporary disable switch for law enforcement, while available BLIS® (Blind Spot Information System) with Cross-Traffic Alert can alert drivers to vehicles in their blind spots before making a lane change.⁵



POLICE RESPONDER

Horsepower, torque, payload and towing are independent attributes and may not be achieved simultaneously.

¹Based on 1977-2020 CY total sales. ²Max. payload varies and is based on accessories. See label on door jamb for carrying capacity of a specific vehicle. ³Max. towing varies based on cargo, accessories and number of passengers.

⁴6000-series aluminum alloy. ⁵Driver-assist features are supplemental and do not replace the driver’s attention, judgment and need to control the vehicle. It does not replace safe driving. See owner’s manual for details and limitations.

SPECIAL SERVICE VEHICLES



REPORTING FOR NON-PURSUIT DUTY

Like the law-enforcement professionals who drive them, these Ford police vehicles are specialized to meet the needs of the communities they serve; each vehicle has been developed with input from the Ford Elite Police Advisory Board. The main objective is to help provide law-enforcement agencies of all stripes with the ideal tools to get things done right.

Totally transformed inside and out, the 2021 Ford F-150® Special Service Vehicle is available with a choice of 3 engines, including a hybrid powertrain – the available 3.5L PowerBoost™ is paired with a hybrid electronic 10-speed SelectShift® automatic transmission. No matter how it's powered, the F-150 SSV is the only way to go when police work requires the capability and dependability of a pickup.

Ford Expedition® and Expedition MAX Special Service Vehicles command authority and can fulfill diverse needs. The comfortable cabin has ample room available for up to 8, along with the necessary space for police equipment! For comparison purposes, the Expedition MAX SSV can accommodate an additional 16.9 cu. ft. of supplies!

Offering multiple configurations to suit your agency's needs,² the unibody, upfit-ready Ford Transit® Prisoner Transport Vehicle (PTV) is available in all-wheel drive (AWD) for outstanding traction and added get-them-where-they-gotta-go assurance. This capable people mover can be configured to exacting needs. It's offered in an outstanding array of heights, lengths and wheelbases, with an option of 2 exemplary powertrains.



70+ YEARS STRONG

Ford has outfitted law enforcement for a full 7 decades. In 1950, Ford became the first manufacturer to offer a police package vehicle, focusing then – as it does now – on the DNA attributes of safety, durability and performance, in addition to being purpose-built and upfit-friendly.

FORD F-150® SSV



ALL WORK. ALL OVER.

Completely redesigned for 2021, the Ford F-150 Special Service Vehicle (SSV) – available with no less than 3 engine choices, including a hybrid option – can fulfill your wish for rough and ready capability. Every powerplant is teamed with a 10-speed SelectShift® automatic with Progressive Range Select. Selectable Drive Modes include Normal, Sport, Eco, Tow/Haul, and Slippery.

3.5L PowerBoost™ Full Hybrid V6 engine. Pulling from the collective power of gas and electric energy, the available 3.5L PowerBoost Full Hybrid engine provides ample horsepower and torque to get the job done – in addition to potentially reduced idle times. Plus, the PowerBoost battery is packaged efficiently underneath the vehicle to avoid taking up space in the cab or cargo bed.

The SSV seats 5 and is available on XL SuperCrew,® as a 4x2 or 4x4. Pair the available 3.5L EcoBoost® V6 with the available Max. Trailer Tow Package to tap into the impressive towing capacity.¹ To help direct the hitch ball to the trailer receiver, the Rear View Camera with Dynamic Hitch Assist provides a visible sight line on the center stack display. Special features also include a high-output 240-amp alternator, cloth front seating with center-section delete, the space-saving convenience of a column-mounted shifter, and a vinyl rear bench and vinyl floor covering for ease of maintenance.

F-150 is made of high-strength, military-grade, aluminum alloys.² These panels don't rust, and they're dent- and ding-resistant. In other words, this SSV is made to stand up to punishment. Its fully boxed, modular frame is comprised of 78% high-strength steel.

Not only is the F-150 SSV Built Ford Tough,® it also comes with Ford Co-Pilot360™ Technology. Standard confidence-driving features include: Pre-Collision Assist with Automatic Emergency Braking (AEB); Autolamp (Automatic On/Off Headlamps) with Auto High Beams; Rear View Camera with Dynamic Hitch Assist; and Trailer Sway Control.

IMMENSELY IMPRESSIVE

Ideal for tactical work, hazardous-materials activity, evidence-tech operations and off-road duty, the Ford Expedition Special Service Vehicle (SSV) – in standard and extended-length MAX versions – can handle all kinds of action, big time. The robust aluminum-alloy body encloses an ultra-refined cabin that has ample room available for up to 8, plus the capacity to hold accompanying cargo.³ Thoughtful design cues include smart connectivity technology and a space-enhancing, fold-flat load floor. A column-mounted shifter and front center-section seat delete make room for onboard equipment. Well-cushioned cloth adorns the front-row bucket seats, and the same cloth comfort is available for the 2nd row. Easy-clean vinyl covers the standard 2nd-row seating, along with the full floor; plus, you get a handy array of 3rd-row storage bins in lieu of 3rd-row seating spaces.

At nearly a foot longer than the standard-length version, the Expedition MAX SSV accommodates an additional 16.9 cu. ft. of supplies and munitions.³ Both Expedition models are provisioned with a potent 3.5L EcoBoost twin-turbocharged direct-injection V6. Delivering a tenacious 375 hp and 470 lb.-ft. of torque, the benefits of this engine become all the more apparent when taking advantage of the max. 9,300-lb. towing brawn.⁴ Stick with RWD, or opt for greater all-terrain confidence with available 4WD, which includes skid plates. You can also benefit from the gains of the 10-speed SelectShift automatic and Auto Start-Stop Technology.

Ford Co-Pilot360 Technology is standard. Numerous confidence-driving features include: Pre-Collision Assist with Automatic Emergency Braking (AEB); BLIS® (Blind Spot Information System) with Cross-Traffic Alert; Lane-Keeping System; Rear View Camera; and Trailer Sway Control.

You're further reinforced with a 3.73 electronic limited-slip differential (eLSD), 17" heavy-duty steel wheels, and all-terrain tires. Take charge, even on rut-strewn rural roads.

FORD EXPEDITION®/EXPEDITION MAX SSV



FORD TRANSIT® PTV



CONFIGURABLE CONVEYANCE

Compartmentalize the Ford Transit Prisoner Transport Vehicle (PTV) with single, double or triple prisoner inserts;¹ add optional surveillance cameras, intercoms, lighting and more.¹ Considerable versatility extends to the best-in-class² choice of vehicle formats: 3 body lengths (Regular, Long, Extended), 3 roof heights (Low, Medium, High), 2 widths and 2 engines; each powerplant is paired with a 10-speed SelectShift[®] automatic.

A significant cargo capacity with a maximum of 5,174 lbs.³ assists this PTV to master demanding challenges. Should extra muscle be required, a substantial gross vehicle weight rating (GVWR) with a maximum of 11,000 lbs.³ comes in handy. As does something as simple as the front overhead shelf that's standard on medium- and high-roof vans. With a flat cargo floor and near-vertical sides, Transit maximizes usable space.

It's loaded with standard Ford Co-Pilot360™ Technology: Pre-Collision Assist with Automatic Emergency Braking (AEB); Post-Collision Braking; Lane-Keeping System; Hill Start Assist; Rear View Camera with Trailer Hitch Assist; Rain-Sensing Windshield Wipers; and Auto High-Beam Headlamps.

Available Intelligent All-Wheel Drive (AWD) helps keep Transit PTV steady as it goes – so does standard AdvanceTrac™ with RSC[®] (Roll Stability Control™) with Side-Wind Stabilization. AWD can make all the difference in getting to a destination. Normal, ECO, Slippery, Mud/Ruts and Tow/Haul are Selectable Drive Modes.

Helping ensure Transit PTV fulfills its missions, development vehicles were subjected to 7 million customer-equivalent miles of brutal testing in labs, at proving grounds, and on roads and highways across America. Overcoming temperature extremes ranging from -40°F to 120°F, this van is most definitely Built Ford Tough.[®]

The new E-Transit Cargo Van combines all the Transit functionality with an all-electric drivetrain for enhanced efficiency. Engineered to offer a targeted EPA-estimated range of 126 miles (low-roof E-Transit cargo van) on a single charge,⁴ E-Transit will offer 3 vehicle roof heights and 3 vehicle lengths. Inside, get next-level connectivity with standard SYNC[®] 4 and next-level productivity with available Pro Power Onboard, which provides 2.4 kW of electrical power to operate tools and equipment on the job site. Look for E-Transit to arrive late 2021.



Mustang Mach-E Premium. Star White Metallic Tri-coat. Available equipment.



Escape Titanium. Ruby Red Metallic Tinted Clearcoat. Available equipment.



Transit Connect XLT Passenger Wagon. Blue Metallic. Available equipment.

SUPPORTING VEHICLES

WHATEVER THE JOB IS, PUT A FORD ON IT

Beyond the family of police-purposed vehicles, Ford Fleet offers you an exhaustive, high-quality portfolio focused on utilities, trucks, vans and wagons. Visit the fleet.ford.com showroom for more specifics, including design, performance, technology, capability, versatility, productivity and smart aspects as applicable to each vehicle.

FORD MUSTANG[®]
Available Fastback & Convertible models: EcoBoost[®], EcoBoost Premium, GT, GT Premium

FORD MUSTANG MACH-E[®]
Available models: Select, California Route 1, Premium, First Edition, GT

FORD ECOSPORT[®]
Available models: S, SE, SES, Titanium

FORD ESCAPE[®]
Available models: S, SE, SEL, Titanium

FORD EDGE[®]
Available models: SE, SEL, Titanium, ST-Line, ST

FORD EXPLORER[®]
Available models: Explorer, XLT, Limited, Limited Hybrid, ST, Platinum

FORD EXPEDITION[®]/EXPEDITION MAX
Available models: XL, XLT, Limited, King Ranch[®], Platinum

FORD F-SERIES[®]
Available Pickup models: F-150, F-250, F-350, F-450
Available Chassis Cab models: F-350, F-450, F-550, F-600, F-650, F-750

FORD TRANSIT CONNECT[®]
Available models: Cargo Van XL, Cargo Van XLT, Passenger Wagon XL, Passenger Wagon XLT, Passenger Wagon Titanium

FORD TRANSIT[®]
Available models: Cargo Van, Crew Van, Passenger Van XL, Passenger Van XLT, Cutaway, Chassis Cab

IN THE NAME OF PROTECTION AND PRECAUTION

- A. Worldwide vehicle exclusive: 75-mph rear-impact crash-tested.**¹ Still the only vehicle on the market engineered to meet this test – which is well above the Federal Motor Vehicle Safety Standard of 50 mph.
- B. Available Police Perimeter Alert.**² It displays moving objects, the motion trail and the level of potential threat. (See page 8 for full details.)
- C. Available Rear Camera On Demand.** Activate it for additional surveillance at any speed, for as long as desired. This technology allows the vehicle's Rear View Camera to be operated independently with the push of a button; not limited to just shifting into Reverse.
- D. Available Level IV+ or Level III+ ballistic front-door panels.**³ Add National Institute of Justice Level IV protection against armor-piercing, .30-caliber rifle ammunition. Level III panels can help resist many handgun and non-armor-piercing bullets up to .30 caliber. Each "+" panel style can also handle specific special-threat rounds identified by the Los Angeles Police Department.
- E. Extra-tough anti-stab plates.** To help keep unruly types at bay, deflective steel intrusion plates are built into the driver and front-passenger seat backs.
- F. SPACE (Side Protection And Cabin Enhancement) Architecture.** A hydroformed cross-vehicle beam solidifies the vehicle's sides.
- G. Multiple airbags.**⁴ Just in case, the front-seat Personal Safety System™ (with front airbags), front-seat side airbags, front-passenger knee airbag, and 1st- and 2nd-row Safety Canopy® System (housing side-curtain airbags) are at the ready.

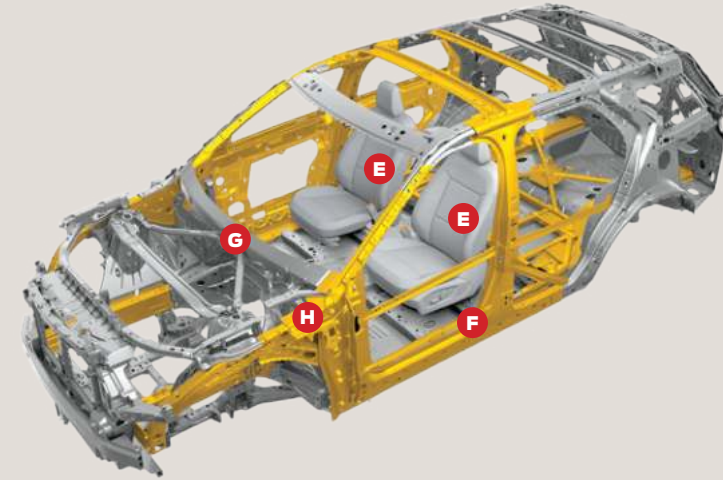

H. Sound surroundings. In the event of a crash, advanced safety technology helps to absorb the energy of the collision and to direct the impact forces away from the occupants. Additionally, crumple zones are strategically placed in the frame or body of the vehicle, further absorbing and dissipating the energy of a crash to help reduce intrusion into the occupant compartment.

I. Manual key lock cylinders. The 3 exterior cylinders – on the front doors and liftgate – provide quick, reliable access with a simple fleet key.

+ Heated Sanitization Solution. This innovative software solution temporarily raises internal vehicle temperatures over 133 degrees Fahrenheit⁵ for at least 15 minutes – long enough to help disinfect vehicle touchpoints to reduce viral concentration (including COVID-19) inside the Police Interceptor Utility by greater than 99% on the interior surfaces and materials used inside – a way to protect law enforcement officers working in frontline conditions.

+ Available hidden rear door-lock plungers. These out-of-sight plungers are manually operable only by officers in front.

+ Available Pre-Collision Assist with Automatic Emergency Braking (AEB).⁶ Sensors help detect a potential collision with a car or pedestrian in front of the vehicle, flashing a warning on the instrument cluster and emitting an audible alert. The brakes will precharge and increase brake-assist sensitivity to provide full responsiveness when applied. If corrective action isn't taken and a collision is imminent, brakes can apply automatically. For law-enforcement demands, simply depress a button for temporary disabling.

+ Standard hands-free Bluetooth® wireless connectivity. Once paired, the Bluetooth system supports hands-free voice calling on mobile devices to help keep hands on the wheel and eyes on the road. Press a switch on the steering wheel, then speak commands.

+ Available Blind Spot Information System. Change lanes with help from available BLIS® (Blind Spot Information System) with cross-traffic alert.⁷

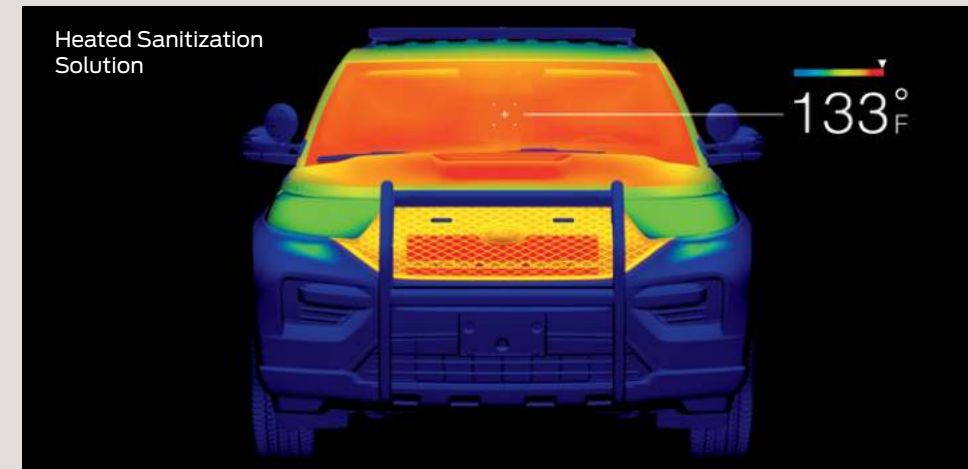

SAFETY & SECURITY



FORD POLICE INTERCEPTOR® UTILITY DNA

¹The full-size spare tire secured in the factory location is necessary to achieve police-rated 75-mph rear-impact crash-test performance attributes. ²System can be configured to meet specific agency needs. ³Contact 1.800.34.FLEET for panel performance specifications. Visit fleet.ford.com for more details. ⁴Always wear your safety belt, secure children in the rear seat and follow airbag warning label instructions. ⁵When applied to factory-built Police Interceptor Utility vehicles. Ambient temperature, installation of partitions or other upfit equipment may impede temperatures from reaching the recommended threshold. ⁶Driver-assist features are supplemental and do not replace the driver's attention, judgment and need to control the vehicle. Pre-Collision Assist with Automatic Emergency Braking detects pedestrians, but not in all conditions, and can help avoid or reduce a collision. It does not replace safe driving. See owner's manual for details and limitations. ⁷Driver-assist features are supplemental and do not replace the driver's attention, judgment and need to control the vehicle. It does not replace safe driving. See owner's manual for details and limitations.

HEAVY-DUTY DURABILITY



FORD POLICE INTERCEPTOR® UTILITY DNA

IN THE NAME OF RELIABILITY AND RUGGEDNESS

Heavy-duty steering and suspension components on the Police Interceptor Utility respond in a controlled, capable manner. Electric power-assisted steering (EPAS) adjusts to vehicle speed, crowned roads and crosswinds. For smooth, predictable, high-speed handling at every turn, the front and multilink rear suspensions are fully independent – each one also incorporates a sturdy stabilizer bar to combat body lean. Helical coil springs and stiffened, gas-pressurized hydraulic shocks are made for the rigors of police work. Premium hubs and bearings are extra-large for extra-long durability. The available unique, Ford designed underbody deflector plate **A** helps divert debris and guard against scrapes – crucial to the integrity of the oil pan. The plate's shape facilitates oil-filter changes.

Heavy-duty anti-lock disc brakes contribute to extreme high performance. Police vehicles don't just need to go fast, they must halt rapidly – under control. Developed in association with the Los Angeles County Sheriff's Department and Michigan State Police, this long-wear-life system's vented rotors **B** are paired with large swept-area calipers **B** and unique pads for high thermal capacity.

Heavy-duty cooling system regulates extreme heat. The high-capacity radiator, engine oil cooler and transmission fluid cooler – working with the police-calibrated fan and grille – help optimize operation in times of pursuit or periods of idling.

Heavy-duty stylized steel wheels are teamed with police-purposed hubcaps and tires. Hefty 18" steel wheels **C** are designed to withstand the punishment of daily duty wherever the trail leads. The 5-spoke-star design lets the brakes breathe freely and stay cool. Tires **C** are constructed to maximize grip, handling, rigidity and tread wear. To keep things rolling, the spare is not only full size, it's equipped with a Tire Pressure Monitoring System (TPMS) sensor. While TPMS is a standard vehicle feature, the Utility takes it one step further with Individual TPMS, which can display exact, tire-by-tire pressure figures.

Heavy-duty 220-amp DC/DC converter on the standard 3.3L V6 Hybrid, along with the 250-amp alternator for the optional conventional powerplants, are more than up to the high demands. There's ample support for lights, radios, computers and other on-board electrical equipment.

Heavy-duty door tethers strengthen hinge action during police work. Instead of the hinges, these supplemental front-door tethers **D** absorb the weight and force of the door when opening, and were tested for structural and mechanical integrity.

Heavy-duty recovery hooks lend an assist as necessary. There's a pair of hooks built into the Class III trailer hitch receiver out back.

All kinds of heavy-duty evaluations: The Police Interceptor Utility is enhanced police durability-cycle tested. It has thoroughly undergone reverse J-turns, median crossings, 30-mph railroad crossings, 8" curb impacts, and water fording conducted to levels of 18" (at 15 mph) and 10" (at 40 mph), and more.



TOTAL PERFORMANCE



IN THE NAME OF POWER AND PURSUIT

Designed exclusively for law-enforcement operations, the Police Interceptor Utility has 3 high-powered powertrain choices to optimize. The standard 3.3L V6 Hybrid propels at a 318 combined system net horsepower and 322 lb.-ft. of combined system net torque.¹ Generating an even more formidable 400 hp² the available twin-turbo, direct-injection 3.0L EcoBoost[®] V6 also delivers a powerful 415 lb.-ft.² flat torque curve across the rev range. Output for the optional flex-fuel 3.3L V6 is a robust 285 horses. Naturally aspirated V6 muscle employs twin independent variable camshaft timing (Ti-VCT) to help with peak power or efficiency, as conditions warrant.

Police-calibrated Intelligent AWD isn't an add-on – it's the standard mode of operation: a full-time, always-active system that continually adjusts torque distribution. And it's easy to operate: Just drive. Preemptive torque is delivered by the millisecond among all 4 wheels to help maximize traction in snow or rain, on ice or gravel, and even when maneuvering over dry pavement. Torque is allocated precisely from the front to the rear, up to 100% of available torque to either axle. There's no delay in delivery: Aggressive handling at any speed is predictable and easy. This unique AWD was co-developed with EVO (Emergency Vehicle Operator Course) instructors for the utmost responsiveness and performance in challenging situations.

In addition, police-programmed AdvanceTrac[™] electronic stability control provides the confidence to hit corners hard.³ The system constantly monitors wheel speeds, steering angle, lateral acceleration, and vehicle rotation for both the vertical yaw axis and horizontal roll axis. To help avoid skidding and fishtailing, it utilizes the Anti-Lock Brake System (ABS) and traction control whenever wheel slip, understeer, oversteer or roll motion is detected. Roll Stability Control[™] has gyroscopic sensors that check body-roll angle at least 100 times per second.

FORD POLICE INTERCEPTOR[®] UTILITY DNA

Pulling from 70+ years of expertise working alongside law enforcement, Ford really took it to the competition⁴ in the latest official testing⁵ by the Michigan State Police (MSP). In the 2021MY MSP testing, the Police Interceptor Utility Hybrid bested the other police utility vehicles in top speed, 0-80 and 0-100 tests.⁴ In sum, it bested even the V8-powered competition. And it turned in improved performance compared to the previous-generation Police Interceptor Utility outfitted with the 3.7L V6. How do you top these exceptional results? Add a Ford Police Interceptor Utility armed with the available all-environment 400-hp² 3.0L EcoBoost V6 to your ranks. Taking MSP testing into consideration as a whole, this indomitable version doesn't just top all police utility vehicles, it even takes V8-powered sedans out of contention. It also demonstrated improved performance in comparison to the previous-generation Police Interceptor Utility equipped with the available 3.5L EcoBoost V6. Los Angeles County Sheriff's Department testing is complete and the 2021 results will be on their website soon.

Shift points for the 10-speed automatic maximize acceleration. The transmission adapts to officer driving habits, tracking maneuvers for optimal response in cruising situations as well as pursuit mode. Police-tuned, electric power-assisted steering (EPAS) helps ensure light turning effort at low speeds. Suspension components are fine-tuned for deft maneuvering at any speed. All of which reinforce the maxim of "Just drive."

Engine and transmission components are backed by the assurance of 5 years or 100,000 miles with Ford Protect[™] PowertrainCARE (with zero deductible);⁶ there's also an 8-year/100,000-mile Hybrid Unique Component Limited Warranty. Here's further proof of the faith in dependability – backed by Ford Motor Company, honored at all Ford Dealerships, and fixed with Ford authorized parts installed by factory-trained and -certified technicians.

3

FUTURE-FORWARD POWERTRAINS, EMPLOYING SMART 10-SPEED AUTOMATIC TRANSMISSIONS AND LIFETIME FUEL FILTERS, OFFER DISTINCT PERFORMANCE ATTRIBUTES AND EFFECTIVENESS



	3.3L V6 Hybrid (Standard)	3.3L V6 Direct-Injection FFV (Available)	3.0L EcoBoost V6 (Available)
Horsepower (hp @ rpm)	318 @ 6,500 combined system net ¹	285 @ 6,500	400 @ 5,500 ²
Torque (lb.-ft. @ rpm)	322 @ 2,500 combined system net ¹	260 @ 4,000	415 @ 3,000 ²
Drivetrain	All-wheel drive	All-wheel drive	All-wheel drive
Top speed (mph) ⁷	136	136	148
Fuel tank (gal.)	19.0	21.4	21.4
	HYBRID	FLEX FUEL	ECOBOOST

Horsepower and torque are independent attributes and may not be achieved simultaneously.

¹Calculated via combined performance of the engine and electric motor(s) with peak battery power. The calculations utilize SAE J1349[®] engine results and Ford electric motor dyno testing. Your results may vary. ²Horsepower and torque ratings based on premium fuel per SAE J1349 standard. Your results may vary. ³Remember that even advanced technology cannot overcome the laws of physics. It's always possible to lose control of a vehicle due to inappropriate driver input for the conditions. Visit fleet.ford.com for more information on AdvanceTrac electronic stability control or AdvanceTrac with RSC[®] (Roll Stability Control). ⁴Excludes other Ford models. ⁵Based on the 0-60 mph, 0-80 mph, 0-100 mph, top speed and vehicle dynamics lap time testing results from the Model Year 2021 Michigan State Police Vehicle Evaluation Program. ⁶The earlier of 5 years or 100,000 miles with PowertrainCARE coverage is a Ford Protect extended service plan – with a zero deductible – that's standard on Police Interceptor Utility, except in Florida and New York, where it is the earlier of 5 years or 100,000 miles with a PowertrainCARE Limited Warranty. See your dealer for full details. In Texas, a Ford Protect extended service plan is a Service Contract from Ford Motor Service Company (License #SCP-165). ⁷Electronically limited in police powertrain calibrations.

PURPOSE-BUILT



FORD POLICE INTERCEPTOR® UTILITY DNA

IN THE NAME OF FORM AND FUNCTION

No surrendering of space. Total interior volume is 170.0 cu. ft., passenger volume is a full 118.0 cu. ft., and cargo volume behind the 2nd row is a generous 52.0 cu. ft. – even with the addition of the hybrid's battery pack, which is located under the vehicle. Dual-zone electronic automatic temperature control (DEATC) helps maintain different preferred comfort levels. And comfort can be optimized with the tilt-and-telescoping steering column.

Free up space for a tidy workplace. The available factory-installed 12.1" Integrated Computer Screen **A** is stationed within easy reach and clear view at the top of the center stack. This smart touchscreen allows portable computers to be stored out of the way, freeing up valuable room in the front row of the cabin. (See page 6 for more details.)

Ergonomic front seats are made for both comfort and calls to action. The driver's seat is 6-way powered and lumbar support is manually adjustable; both benefits are available for the front-passenger seat. The premium foam padding in each front seat is specially sculpted for officers' utility belts **B**, making it easier to buckle in safely, comfortably and effortlessly – even when packing a sidearm. Side bolsters are slim-styled, as is the high-strength-steel B-pillar, to address the frequent entering and exiting of the cabin every shift. Front seat fabric is ultra-durable, with seat wear resistance against gun butts and duty belts test-proven to be long-lasting. Anti-stab plates in the seat backs provide an added measure of got-your-back reassurance.

The rear seat doesn't take a back seat to attention. Wide-opening rear doors make 2nd-row ingress/egress a no-problem matter. The simplified rear-door closeout panels have no map pockets or cupholders, reducing opportunities to hide contraband. Available hidden door lock plungers, accessible only from the front-row door jambs, are manually activated to secure occupant containment in back. Rear seats come covered in durable vinyl **C**. The optional Police Interior Upgrade Package includes a carpeted floor, carpeted floor mats, a center floor console with cupholders, and a heavy-duty cloth rear seat.

Details that matter. The column-mounted shifter frees up the center console. The certified speedometer (also available in digital format) provides at-a-glance readouts. To help with vehicle maintenance, track engine-hour usage and engine-idle-hour usage through the odometer. The cluster LCD screen is operated by 5-way steering wheel-mounted controls, while the 4.1" center stack screen is controlled by the radio ECP buttons. Stealthy red/white task lighting **D** helps keep operations under wraps. Flooring throughout is covered in heavy-duty vinyl for easy clean-up.

Simplified access measures. The liftgate release **E** is finger-touch-activated, operating on a 45-second timer for added security to help protect valuables in the rear cargo area; and a global lock/unlock for the doors and liftgate is a no-charge option when extra security isn't required. Every Police Interceptor Utility comes with a set of 4 simple fleet keys, making for a cost-effective strategy: The availability of keyed-alike sets allows use of just a "single key" for the entire fleet. And since the key doesn't have a microchip, replacement costs are minimized. Optionally, the Remote Keyless Entry System includes 4 pre-programmed key fobs.

Plus, a built-in modem with a complimentary 2-year subscription to Ford Telematics™ for law enforcement.¹ This powerful and purpose-built solution helps promote officer safety and increase fleet efficiency through secure access to real-time data. (See page 10 for more details.)





IN THE NAME OF CUSTOMIZATION AND CONVENIENCE

To help dramatically reduce upfitting time, Ford offers optional, compatible, factory-direct police equipment that's first-rate. Save administrative time, shop time and vehicle downtime with expert factory installation, utilizing components available individually or in complete packages; everything is verified exactly as part of the Ford Quality System. Crash testing, cycle testing, vibration, severe temperature, humidity and corrosion are evaluated extensively. All parts – such as the available Ready-for-the-Road Package system controller **A** – are validated to vehicle manufacturer safety standards and backed by Ford Dealers and authorized Ford Fleet maintenance facilities; they're also covered under the Ford factory warranty! For technical information that can be used as a checklist to help ensure important steps in the modification process are considered, **download an official Ford Police Modifiers Guide at fordpolicevehicles.com.**

Standard, customizable auxiliary control buttons, supported by a remarkable electrical system. Help keep distraction to a minimum while performing police tasks on the go: 4 user-configurable latching switches **F** are integrated on the steering wheel. These standard switches connect the driver with installed equipment, including lights, sirens, speakers, K9 door releases and other police applications, while helping keep hands on the wheel and eyes on the road. Whatever the need, grounded outputs are onboard for use with the switches, plus 12-volt powerpoints **G** are easily accessed in both the front-passenger cabin and rear cargo area. And the standard Police Interceptor Utility – with its unique hybrid system – comes with a substantial 220-amp DC/DC converter to handle the gamut of on-board electrical equipment; Police Interceptors ordered with other optional powerplants feature an impressive 250-amp alternator in lieu of a converter.



Everything in its place. A standard 9"-wide front console mounting plate **B** is a solid foundation for attaching aftermarket equipment and channeling wiring; space actually measures a wide-open 11" between the driver and front-passenger seats. To streamline upfitting, a rear console plate **C** is available to interface with the front plate. It extends through the 2nd-row occupant area, acting as a wiring conduit on top of the transmission tunnel – providing a path from the instrument panel center stack, all the way into the rear cargo area. There's also the option of a rear-center seat section delete. A pair of 50-amp battery power circuits are included with the standard power distribution junction block in back. The column-mounted shifter **D** is a durable space-saver, freeing up the center-console space to make way for police equipment and ensuring accurate, reliable shifting. Up front, the reinforced universal top tray **E** is centrally located for mounting radar equipment or ticket printers.

Shining array of available lighting solutions are tailored specifically to this Police Interceptor Utility. Headlamps are automatic on/off and feature LED low- and high-beam functions, with factory-integrated wig-wag functionality and pre-drilled holes for user-installed warning strobes. Intense, long-lasting LEDs provide optimum visibility and heads-up performance. They fully comply with SAE Emergency Lighting Standards. (See pages 42-43 for full lighting solutions.)

The available vault acts undercover. Positioned on the driver's side of the cargo area, this lockable vault **H** is a convenient place to store ammo and small weapons, seized firearms, drugs, and/or other assorted small goods and paraphernalia. Speaking of undercover, opt for the available exterior police badging delete, and then clip on a set of available full-face wheel covers to create a stealth-like appearance for administrative, detective and investigative ops.



FORD POLICE INTERCEPTOR® UTILITY DNA

STANDARD FEATURES

- 4.2" color LCD screens including digital speed readout in police instrument cluster and center stack "smart display"
- 11" space between driver's seat and front-passenger seat for aftermarket consoles
- 12V powerpoint, front
- 50-state emissions system
- 75-mph rear-impact crash tested¹
- AdvanceTrac™ with RSC® (Roll Stability Control™)
- All-wheel drive (AWD)
- Alternator – 250-amp (3.3L Gas and 3.0L EcoBoost®)
- Audio – AM/FM stereo with Bluetooth® interface, USB port, MP3 capability, clock and 6 speakers
- Badge – Police Interceptor
- Battery – H7 AGM (80-amp-hr/800-CCA) (3.3L Hybrid)
- Battery – H7 SLI (80-amp-hr/730-CCA) (3.3L Gas and 3.0L EcoBoost)
- Built-in steel intrusion plates in both front seat backs
- Cargo area – Flat load floor
- Class III trailer hitch receiver with 5,000-lb. towing capacity, Trailer Tow Lighting Package, and 2 recovery hooks
- Climate controls – Dual-zone electronic automatic temperature control
- Column-mounted shifter
- Console mounting plate – Front
- Cooling system – Heavy-duty
- Cruise control
- Dash pass-through for aftermarket wiring
- DC/DC converter – Heavy-duty 220-amp (3.3L Hybrid)
- Door-sill scuff plates – Front and rear
- Easy Fuel® capless fuel filler
- Electric power-assisted steering – Heavy-duty
- Engine – 3.3L V6 Hybrid System with lithium-ion battery pack
- Engine-hour meter
- Engine-idle-hour meter
- Exterior key locks – Front doors and liftgate

- Fleet key – Low-cost replacement (includes 4 keys)
- Flooring – Heavy-duty vinyl
- Ford Telematics™ modem and complimentary 2-year subscription²
- Full-size spare wheel and tire with TPMS
- Glass – Solar-tinted front row; privacy glass on all rear windows
- Headlamps – LED low and high beams with Autolamp, integrated wig-wag functionality, and pre-drilled holes for user-installed warning strobes. Wig-wag factory-configured as traditional "ping-pong" with 2 additional programmable modes.
- Headliner – Easy-to-drop
- Heated Sanitization Solution
- Independent front and rear suspensions
- Liftgate release switch – Overhead console
- Mirrors – Power sideview, manual foldaway with integrated blind spot mirrors
- Power distribution junction block with two (2) 50-amp battery power circuits
- Power door locks
- Power windows with front one-touch-up/-down and disable feature
- Powertrain mounts – Heavy-duty
- Rear View Camera with washer
- Rear-window defroster
- Red/white map lights – 1st row
- Redundant digital speedometer display
- Seat – Heavy-duty cloth front, 6-way power driver's with manual lumbar
- Seat – Heavy-duty cloth front-passenger
- Seats – Vinyl rear 35/30/35 split-fold bench
- SOS Post-Crash Alert System™
- Taillamps – LED
- Tilt/telescoping steering column
- Tires – 255/60R18 all-season BSW
- Transmission – 10-speed automatic (police-calibrated)
- Universal top tray for police equipment
- Wheels – Heavy-duty 18" 5-spoke steel

STANDARD SAFETY & SECURITY

- 4-wheel heavy-duty disc brakes with Anti-Lock Brake System (ABS) (police-calibrated)
- Advanced, ultra-high-strength boron steel in the A-, B- and C-pillars
- Front-seat side and front-passenger knee airbags, plus Safety Canopy® system with side-curtain airbags and rollover sensor
- Personal Safety System™ for driver and front passenger with dual-stage front airbags³
- Regenerative Braking System (3.3L Hybrid)
- Tire Pressure Monitoring System (TPMS); features a true-location Individual TPMS
- Traction control

DRIVETRAIN

Police Interceptor Utility (AWD) – Standard K8A

POWERTRAINS

- 3.3L V6 Direct-Injection Hybrid Engine System with 10-Speed Automatic Transmission (top speed 136 mph) 99W/44B
- 3.3L V6 Direct-Injection with 10-Speed Automatic Transmission (top speed 136 mph) 99B/44U
- 3.0L V6 EcoBoost with 10-Speed Automatic Transmission (top speed 148 mph) 99C/44U

WHEELS



Standard: Set of 5 heavy-duty 18" 5-spoke steel wheels with center caps (5th wheel is full-size spare)



Optional: Set of 4 18" full-face wheel covers with metal clips (65L)



Optional: Set of 4 18" painted aluminum wheels (64E)

EXTERIOR COLORS

Oxford White (YZ)	Smokestone Metallic (HG)	Arizona Beige Metallic (E3)	Medium Brown Metallic (BU)
Kodiak Brown Metallic (J1)	Vermillion Red (E4)	Dark Toreador Red Metallic (JL)	Light Blue Metallic (LN)
Royal Blue (LM)	Blue Metallic (FT)	Dark Blue (LK)	Medium Titanium Metallic (YG)
Carbonized Gray Metallic (M7)	Iconic Silver Metallic (JS)	Silver Gray Metallic (TN)	Sterling Gray Metallic (UJ)
Agate Black Metallic (UM)			

INTERIOR COLORS

Charcoal Black heavy-duty cloth (standard for front row, optional for rear row)	Charcoal Black heavy-duty vinyl (standard for rear row)

Because of occasional variations in printing, consult your Ford Dealer to ensure the true color choice you make is correct. Colors shown are representative only. See your dealer for actual paint/trim options. Visit fleet.ford.com for more information on colors and special paint options.



¹The full-size spare tire secured in the factory location is necessary to achieve police-rated 75-mph rear-impact crash-test performance attributes. ²2-year subscription for Ford Telematics starts on vehicle warranty start date. Subscription features may be limited. Factors causing this limitation may include, but are not limited to, issues related to cellular coverage, carrier outages and carrier network service interruptions. Complimentary service ends after 2 years. ³Includes dual-stage front airbags, safety belt pretensioners, safety belt energy-management retractors, safety belt usage sensors, driver's seat position sensor, crash severity sensor, restraint control module and Front-Passenger Sensing System.

AVAILABLE PACKAGES

Refer to pages 42-46 for full descriptions.

Front Headlamp Lighting Solution	<input type="checkbox"/> 66A
Police Interior Upgrade Package	<input type="checkbox"/> 65U
Police Wire Harness Connector Kit – Front and rear	<input type="checkbox"/> 67V
Ready-for-the-Road Package	<input type="checkbox"/> 67H
Rear Lighting Solution	<input type="checkbox"/> 66C

AVAILABLE FEATURES¹

1st- and 2nd-row carpeting	<input type="checkbox"/> 16C
8-way power front-passenger seat with manual lumbar and recline	<input type="checkbox"/> 87P
12.1" Integrated Computer Screen (ICS)	<input type="checkbox"/> 47E
18" full-face wheel covers (4)	<input type="checkbox"/> 65L
18" painted aluminum wheels (4)	<input type="checkbox"/> 64E
100-watt siren/speaker	<input type="checkbox"/> 18X
Badge delete – Deletes all "Interceptor" badging	<input type="checkbox"/> 16D
Ballistic door panel (Level III+) – Driver's door	<input type="checkbox"/> 90D
Ballistic door panels (Level III+) – Driver and front-passenger doors	<input type="checkbox"/> 90E
Ballistic door panel (Level IV+) – Driver's door	<input type="checkbox"/> 90F
Ballistic door panels (Level IV+) – Driver and front-passenger doors	<input type="checkbox"/> 90G
Battery – H8 AGM (92-amp-hr/850-CCA)	<input type="checkbox"/> 19K
BLIS® (Blind Spot Information System) with Cross-Traffic Alert and heated sideview mirrors	<input type="checkbox"/> 55B
Cargo area storage vault (Includes lockable door)	<input type="checkbox"/> 63V
Climate control – Auxiliary air conditioning	<input type="checkbox"/> 17A
Dark Car Feature	<input type="checkbox"/> 43D
Daytime running lamps	<input type="checkbox"/> 942
Dome light – Red/white in cargo area	<input type="checkbox"/> 17T
Engine block heater	<input type="checkbox"/> 41H
Front console mounting plate delete ²	<input type="checkbox"/> 85D
Front Interior Visor Light Bar	<input type="checkbox"/> 96W
Front warning auxiliary lamps	<input type="checkbox"/> 21L
Glass – Solar-tinted 2nd row, rear quarter and liftgate window	<input type="checkbox"/> 92G
Glass – Solar-tinted 2nd row; privacy glass on rear quarter and liftgate window	<input type="checkbox"/> 92R
Global lock/unlock	<input type="checkbox"/> 18D
Heated sideview mirrors	<input type="checkbox"/> 549
Hidden door-lock plungers with rear-door controls inoperable (locks, handles and windows)	<input type="checkbox"/> 52P
Keyed alike – 1435x	<input type="checkbox"/> 59E
Keyed alike – 1284x	<input type="checkbox"/> 59B
Keyed alike – 1294x	<input type="checkbox"/> 59C
Keyed alike – 0135x	<input type="checkbox"/> 59D

Taillamp Housing	<input type="checkbox"/> 86T
Taillamp Lighting Solution	<input type="checkbox"/> 66B
Ultimate Wiring Package	<input type="checkbox"/> 67U

Keyed alike – 0576x	<input type="checkbox"/> 59F
Keyed alike – 0151x	<input type="checkbox"/> 59G
Keyed alike – 1111x	<input type="checkbox"/> 59J
Low-band frequency noise suppression kit	<input type="checkbox"/> 68E
Noise-suppression bonds	<input type="checkbox"/> 60R
OBD-II Split Connector	<input type="checkbox"/> 61B
Perimeter alarm (requires Remote Keyless Entry System)	<input type="checkbox"/> 593
Police Engine Idle feature	<input type="checkbox"/> 47A
Police Perimeter Alert	<input type="checkbox"/> 68B
Pre-Collision Assist with Automatic Emergency Braking (AEB) includes unique disable button for law enforcement use	<input type="checkbox"/> 76P
Pre-wiring for grille lamp, siren and speaker	<input type="checkbox"/> 60A
Rear auxiliary liftgate lights	<input type="checkbox"/> 43A
Rear camera on-demand	<input type="checkbox"/> 19V
Rear center seat delete	<input type="checkbox"/> 85S
Rear console plate ²	<input type="checkbox"/> 85R
Rear-door controls inoperable (locks, handles and windows)	<input type="checkbox"/> 68G
Rear spoiler LED traffic warning lights	<input type="checkbox"/> 96T
Rear View Camera – Image displayed in rearview mirror	<input type="checkbox"/> 87R
Remote Keyless Entry System (includes 4 key fobs)	<input type="checkbox"/> 55F
Reverse Sensing System	<input type="checkbox"/> 76R
Seat – Rear heavy-duty cloth	<input type="checkbox"/> 88F
Side marker LED lamps – Rear quarter glass	<input type="checkbox"/> 63L
Side marker LED lamps – Sideview mirrors	<input type="checkbox"/> 63B
Spot lamp, LED bulb, Unity® – Driver and front-passenger	<input type="checkbox"/> 51S
Spot lamp, LED bulb, Unity – Driver only	<input type="checkbox"/> 51R
Spot lamp, LED bulb, Whelen® – Driver and front-passenger	<input type="checkbox"/> 51V
Spot lamp, LED bulb, Whelen – Driver only	<input type="checkbox"/> 51T
Spot lamp prep – Driver and front-passenger	<input type="checkbox"/> 51W
Spot lamp prep – Driver only	<input type="checkbox"/> 51P
Underbody deflector plate	<input type="checkbox"/> 76D

DIMENSIONS & CAPACITIES³

EXTERIOR (in.)	
Length	198.8
Wheelbase	119.1
Width (excluding mirrors/including mirrors)	78.9/89.3
Height (excluding options)	69.3
Step-in height	18.6
Cargo rear opening height	31.9
Cargo rear opening width at floor	47.6
Liftover height (ground to cargo deck)	30.9
Liftgate to ground (when raised)	73.0
Ground clearance	7.6

INTERIOR (in.)	
Front	
Head room	40.7
Leg room (max.)	40.9
Hip room	59.3
Shoulder room	61.8
Rear	
Head room	40.4
Leg room	40.7
Hip room	59.1
Shoulder room	61.3

CAPACITIES	
Passenger volume (cu. ft.)	118.0
Cargo area volume with full-size spare (cu. ft.)	90.3 (behind 1st row); 52.0 (behind 2nd row)
Total interior volume (cu. ft.)	170.0
GVWR (lbs.)	6,840 (3.3L V6 Hybrid); 6,465 (3.3L V6 FFV); 6,500 (3.0L EcoBoost®)

Max. payload (lbs.)	1,670
Cargo capacity (lbs.)	880
Fuel (gal.)	19.0 (3.3L V6 Hybrid); 21.4 (3.3L V6 FFV/3.0L EcoBoost)

Seating	5
---------	---



Inoperable rear-door controls



Pre-Collision Assist with AEB



BLIS mirror



Pre-Collision Assist disable button (left), Police Perimeter Alert activation button (right)



H8 AGM 12V battery



Rear camera on-demand Rear View Camera displayed in rearview mirror



F-150 Police Responder. Agate Black Metallic. Available and aftermarket upfit equipment.



STANDARD FEATURES

SuperCrew® 4x4 with 5.5' box

- 2-speed Torque-On-Demand® 4x4 transfer case
- 12V powerpoints, front (2)
- AdvanceTrac™ with RSC® (Roll Stability Control™)
- Alternator – 240-amp
- Audio – AM/FM stereo with 6 speakers
- Autolamp (Automatic On/Off Headlamps)
- Built-in steel intrusion plates in both front seat backs
- Cargo box tie-downs (4)
- Class IV trailer hitch receiver with 4-pin/7-pin wiring harness and Smart Trailer Tow Connector
- Column-mounted shifter
- Engine – 3.5L EcoBoost® V6
- Engine-hour and engine-idle-hour meters
- Flooring – Black vinyl
- Ford Telematics™ modem¹
- Front-seat side airbags, and Safety Canopy® System with side-curtain airbags and rollover sensor
- FX4™ Off-Road Package includes electronic-locking rear axle, Hill Descent Control,™ off-road-tuned shock absorbers, and skid plates on the fuel tank, transfer case and front differential
- Keys – Simple fleet keys (4)
- Mirrors – Power sideview with heated glass
- Perimeter alarm
- Personal Safety System™ for driver and right-front passenger with dual-stage front airbags
- Power lug located underneath rear seat to accommodate Police upfitting; one (1) 80-amp battery ground circuit

- Power windows and door locks
- Rear View Camera with Dynamic Hitch Assist
- Red/white task lighting in overhead console
- Reinforced universal I/P top tray for mounting equipment
- Reverse Sensing System
- Seats – Police-grade heavy-duty cloth, 8-way power driver and 4-way manual front-passenger with reduced bolsters and center-seat section deleted (40/blank/40 front seats)
- Seats – Vinyl rear bench
- SecuriLock® Passive Anti-Theft System
- SOS Post-Crash Alert System™
- Speedometer – Police-calibrated with digital readout
- SYNC® 4 with 8" LCD center stack touchscreen, cloud connectivity and wireless Software Updates
- Tire Pressure Monitoring System (excludes spare)
- Tires – LT265/70R18C BSW all-terrain
- Trailer Sway Control
- Transmission – 10-speed SelectShift® automatic with Selectable Drive Modes: Normal, Tow/Haul, Snow/Wet, EcoSelect and Sport
- Upgraded power 4-wheel vented disc brakes with Anti-Lock Brake System (ABS)
- Wheels – 18" silver-painted aluminum

ENGINE

ENGINE	Transmission	Horsepower (hp @ rpm)	Torque (lb.-ft. @ rpm)
3.5L EcoBoost 4-valve V6	10-speed SelectShift automatic	400 @ 6,000	500 @ 3,100

F-150 Police Responder was designed and developed to meet the same federal fuel system crash standards as retail vehicles and other manufacturers' police vehicles. Ford Police Interceptor® Utility is the only vehicle on the market designed for the 75-mph rear-impact crash test.

AVAILABLE FEATURES

- Backup alarm system (85H)
- Badge delete (41A)
- Bed divider (90D)
- Bedliner – Plastic drop-in (96P)
- Bedliner – Tough Bed® spray-in (96W)
- Black platform running boards (18B)
- BLIS® (Blind Spot Information System) with Cross-Traffic Alert (91B)
- BoxLink™ with 4 premium locking cleats (55B)
- Chrome front and rear bumpers (17C)
- Daytime running lamps – Non-configurable (942)
- Engine block heater (41H)
- Fixed rear window with privacy glass and defroster (924/57Q)
- Flooring – Carpet with carpeted floor mats (168)
- Flooring – Floor liners (47R)
- Fog lamps (595)
- Integrated trailer brake controller (67T)
- Interior Upgrade Package² (61A)
- Interior Work Surface (50M)
- Keys – Keyed alike (62B/62C/62D/62E/62F/62G/62J)
- LED warning beacons (Red/Blue 94R; Amber 94S; Amber/White 94W)
- Mirrors – Manually folding, power, heated sideview with integrated turn signal indicators, high-intensity LED security approach lamps, LED spotlights, driver's side auto-dimming feature, and black mirror caps (54R/59S)
- Mirrors – Manually folding/telescoping trailer tow with power, heated glass; integrated turn signal indicators; high-intensity LED security approach lamps; LED spotlights; and black mirror caps (54Y/59S)
- Police engine idle feature (47P)
- Power-sliding rear window (435)
- Pre-Collision Assist with Automatic Emergency Braking (AEB) with temporary disable switch (60C)

- Remote Keyless Entry System with 4 key fobs (67P)
- Seat – 8-way power front-passenger (61P)
- Stowable loading ramps (90R)
- SYNC® 4 with cloud connectivity – wireless phone connection, 911 Assist®, AppLink® with App Catalog, wireless Apple CarPlay® compatibility, wireless Android Auto™ compatibility, and digital owner's manual (524)
- Tailgate step with tailgate work surface (63T)
- Tonneau cover – Hard-folding by Advantage³ (96X)
- Tonneau cover – Retractable³ (96J)
- Tonneau cover – Soft-folding by Advantage³ (96T)
- Toolbox – Aluminum crossbed³ (90B)
- Toolbox – Premium aluminum crossbed³ (90P)
- Tow Technology Package² (17T)
- Trailer Tow Package with Pro Trailer Backup Assist™² (53A)

CARGO AREA⁴

CARGO AREA (in.)	5½' Styleside Box
Length at floor	67.1
Width at wheelhouse	50.6
Maximum width inside box	65.2
Volume (cu. ft.)	52.8

DIMENSIONS & CAPACITIES⁴

EXTERIOR (in.)	SuperCrew	INTERIOR (in.)	SuperCrew
Length	231.7	Rear	
Wheelbase	145.4	Head room	40.4
Width (standard mirrors folded)	79.9	Leg room	43.6
Height	77.2	Hip room	62.6
Approach angle	24.3°	Shoulder room	66.0
Departure angle	25.3°	CAPACITIES	
Ground clearance	9.4	Passenger volume (cu. ft.)	131.9
		Fuel (gal.)	26.0
		Max. payload (lbs.)	2,030
		Std. towing (lbs.)	7,000
		Max. towing (lbs.)	11,200 ⁵
		GVWR (lbs.)	7,050
		Seating	5

EXTERIOR COLORS⁶



INTERIOR COLOR

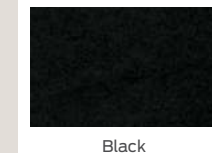

Horsepower, torque, and towing are independent attributes and may not be achieved simultaneously.

¹Available on vehicles with embedded modem or equipped with plug-in device (PID). Requires modem activation. Ford Telematics and Ford Data Services™ are subscription services subject to agreement to FSM terms and conditions. Subscription subject to monthly charge. Subject to OFAC and credit check for subscription eligibility. Connected service and features, and access to vehicle data depend on subscription and compatible AT&T network availability. Evolving technology/cellular networks/vehicle capability may limit functionality and prevent operation of connected features. ²Visit fleet.ford.com for complete package content. ³Ford Licensed Accessory. ⁴Dimensions and capacities shown may vary due to optional features and/or production variability. ⁵Requires available Trailer Tow Package. Max. towing varies based on cargo, vehicle configuration, accessories and number of passengers. ⁶Available on select series. Restrictions may apply. See your dealer for details. ⁷New for 2021.

2021 FORD F-150® SSV SPECS



F-150 XL SuperCrew® 4x4. Agate Black Metallic. Available and aftermarket upfit equipment.

SPECIAL SERVICE VEHICLE (SSV) PACKAGE (66S)

- Available on XL SuperCrew only
- 5.0L Ti-VCT 4-valve V8 FFV, 3.5L EcoBoost® 4-valve V6 or 3.5L PowerBoost™ hybrid engine
- 240-amp alternator
- Cloth 40/blank/40 front seats (SG) with center-seat section deleted (restraint control module cover provided)
- Vinyl rear bench seat and floor covering

STANDARD FEATURES

4x2
12V powerpoint, front
26.0-gallon fuel tank capacity
AdvanceTrac™ with RSC® (Roll Stability Control™) and Curve Control
Cargo box tie-downs (4)
Column-mounted shifter
Cruise control (XL 101A)
Daytime running lamps – Configurable
Easy Fuel® capless fuel filler
Flooring – Black vinyl
FordPass™ Connect ¹ with 4G LTE Wi-Fi hotspot capability ²
Front-seat side airbags, and Safety Canopy® System with side-curtain airbags and rollover sensor
Mirrors – Power sideview
MyKey®
Personal Safety System™ for driver and right-front passenger with dual-stage front airbags

Power 4-wheel vented disc brakes with Anti-Lock Brake System (ABS)
Power lug located underneath rear seat to accommodate Police upfitting; one (1) 80-amp battery ground circuit
Power windows and door locks
Quick-release tailgate with lock
Rear View Camera with Dynamic Hitch Assist
Remote Keyless Entry System
SecuriLock® Passive Anti-Theft System
SOS Post-Crash Alert System™
SYNC® 4 with 8" LCD center stack touchscreen, cloud connectivity and wireless Software Updates
Tire Pressure Monitoring System (excludes spare)
Tires – 245/70R17 all-season BSW (4x2)
Tires – 265/70R17 all-terrain OWL (4x4)
Trailer Sway Control
Wheels – 17" silver steel

ENGINES

ENGINE	Transmission (with progressive range select and tow/haul mode)	Horsepower (hp @ rpm)	Torque (lb.-ft. @ rpm)
3.5L EcoBoost 4-valve V6	10-speed SelectShift automatic	400 @ 6,000	500 @ 3,100
5.0L Ti-VCT 4-valve V8 FFV	10-speed SelectShift automatic	400 @ 6,000	410 @ 4,250
3.5L PowerBoost hybrid	HEV electronic 10-speed automatic	430 @ 6,000 ³	570 @ 3,000 ³

AVAILABLE PACKAGES⁴

Ford Co-Pilot360™ 2.0 (43A)	STX® Appearance Package (61S)
FX4™ Off-Road Package (55A)	Tow Technology Package (17T)
Heavy-Duty Payload Package (627)	Trailer Tow Package (53A)
Max. Trailer Tow Package (53C)	XL Chrome Appearance Package (86A)

Not rated for pursuit.

AVAILABLE FEATURES

4x4 with electronic shift-on-the-fly (ESOF)
Backup alarm system (85H)
Black platform running boards (18B)
BoxLink™ with 4 premium locking cleats (55B)
Class IV trailer hitch receiver (53B)
Daytime running lamps – Non-configurable (94Z)
Engine block heater (41H)
Fixed rear window with privacy glass and defroster (924/57Q)
Flooring – Floor liners (47R)
Fog lamps (595)
Integrated trailer brake controller (67T)
Mirrors – Manually folding, power, heated sideview with integrated turn signal indicators, high-intensity LED security approach lamps, driver's side auto-dimming feature, and black mirror caps (54R/59S)
Plastic drop-in bedliner (96P)
Pro Power Onboard 2.0kW (47Z)
Pro Power Onboard 2.4kW (included with PowerBoost engine)
Pro Power Onboard 7.2kW (477)
Pro Trailer Hitch Assist (63H)
Reverse Sensing System

Skid plates (4x4) (413)
Snow plow prep (68P)
Stowable loading ramps (90R)
SYNC® 4 with cloud connectivity – wireless phone connection, 911 Assist® AppLink® with App Catalog, wireless Apple CarPlay® compatibility, wireless Android Auto™ compatibility, and digital owner's manual (524/582)
Tailgate step with tailgate work surface (63T)
Tires – LT245/70R17E all-terrain BSW (T7C)
Tonneau cover (96X, 96T or 96J)
Tough Bed® spray-in bedliner (96W)

CARGO AREA⁵

CARGO AREA (in.)	5½' Styleside Box	6½' Styleside Box
Length at floor	67.1	78.9
Width at wheelhouse	50.6	50.6
Maximum width inside box	65.2	65.2
Volume (cu. ft.)	52.8	62.3

DIMENSIONS & CAPACITIES⁵

DIMENSIONS (in.)	SuperCrew	
	5½' Box	6½' Box
Wheelbase	4x2/4x4 145.4	157.2
Length	4x2/4x4 231.7	243.5
Height	4x2/4x4 75.6/77.2	75.8/77.6
Width (standard mirrors folded)	4x2/4x4 83.6	83.6
CAPACITIES		
Passenger volume (cu. ft.)	Total 131.9	131.9
Fuel (gal.)	4x2/4x4 26.0 (gas); 30.6 (hybrid); (36.0 optional)	26.0 (gas); 30.6 (hybrid); (36.0 optional)
Max. payload ⁶ (lbs.)	4x2/4x4 2,335 ⁷ /2,135	2,900 ⁸ /2,650 ⁸

EXTERIOR COLORS⁹



INTERIOR COLOR



Horsepower, torque and payload are independent attributes and may not be achieved simultaneously.

¹FordPass Connect, the FordPass App, and complimentary Connected Service are required for remote features (see FordPass Terms for details). Connected service and features depend on compatible AT&T network availability. Evolving technology/cellular networks/vehicle capability may limit functionality and prevent operation of connected features. Connected service excludes Wi-Fi hotspot. FordPass App, compatible with select smartphone platforms, is available via download. Message and data rates may apply. ²Wi-Fi hotspot includes complimentary wireless data trial that begins upon AT&T activation and expires at the end of 3 months or when 3GB of data is used, whichever comes first, but cannot extend beyond the complimentary subscription period for remote features. To activate, go to www.att.com/ford. ³Calculated via combined performance of the engine and electric motor(s) with peak battery power. The calculations utilize SAE J1349® engine results and Ford electric motor dyno testing. Your results may vary. ⁴Visit fleet.ford.com for complete package content. ⁵Dimensions and capacities shown may vary due to optional features and/or production variability. ⁶Max. payload varies and is based on accessories and vehicle configuration. See label on door jamb for carrying capacity of a specific vehicle. ⁷Requires 5.0L engine and available Max. Trailer Tow Package. ⁸Requires 5.0L engine and available Max. Trailer Tow and Heavy-Duty Payload Packages. ⁹Available on select series. Restrictions may apply. See your dealer for details. ¹⁰New for 2021.

2021 FORD EXPEDITION® / EXPEDITION MAX SSV SPECS



Expedition XL. Agate Black Metallic. Available and aftermarket upfit equipment.

SPECIAL SERVICE VEHICLE (SSV) PACKAGE (102A)

- Available on XL only
- 17" steel wheels (265/70R17 all-terrain OWL tires)
- 3.73 electronic limited-slip differential (eLSD)
- 3rd-row storage bins
- Column-mounted shifter
- Floor console delete
- Keyless entry – Integrated key transmitters (2)
- Running boards delete
- Vinyl floor covering
- Vinyl 2nd-row seat

STANDARD FEATURES

4-wheel disc brakes with Anti-Lock Brake System (ABS)
 12V powerpoints (4)
 AdvanceTrac™ with RSC® (Roll Stability Control™)
 Air conditioning with rear auxiliary controls
 Audio – AM/FM stereo with MP3 capability and 6 speakers
 Autolamp (Automatic On/Off Headlamps)
 Class IV trailer hitch receiver
 Daytime running lamps – Configurable
 Easy Fuel® capless fuel filler
 Electric power-assisted steering
 Engine – 3.5L EcoBoost® V6 with Auto Start-Stop Technology
 Ford Co-Pilot360™ – Auto High-Beam Headlamps; BLIS® (Blind Spot Information System) with Cross-Traffic Alert; Lane-Keeping System (includes Lane-Keeping Assist, Lane-Keeping Alert and Driver Alert System); Pre-Collision Assist with Automatic Emergency Braking (AEB) (includes Pedestrian Detection, Forward Collision Warning and Dynamic Brake Support); Rear View Camera
 Front-seat side airbags, and 3-row Safety Canopy® System with side-curtain airbags and rollover sensor
 Halogen headlamps with rainlamp
 Hill Start Assist

Individual Tire Pressure Monitoring System (TPMS; excludes spare)
 Mirrors – Manual-folding, power, heated sideview with security approach lamps
 MyKey®
 Perimeter alarm
 Personal Safety System™ for driver and front passenger with dual-stage front airbags
 Power door locks
 Power windows with front one-touch-up/-down feature
 Rear-wheel drive (RWD)
 Seats – Cloth 1st-row buckets with recline and 8-way power driver's with power lumbar support; vinyl 2nd-row 40/20/40 split (CenterSlide®) with recline
 SecuriCode® keyless entry keypad
 SecuriLock® Passive Anti-Theft System
 SOS Post-Crash Alert System™
 SYNC®
 Tilt steering column
 Tow hooks (4x4)
 Tires – 265/70R17 all-terrain OWL
 Trailer Sway Control
 Transmission – 10-speed SelectShift® automatic
 Wheels – 17" steel

ENGINE¹

ENGINE	Transmission	Horsepower (hp @ rpm)	Torque (lb.-ft. @ rpm)
3.5L EcoBoost 4-valve V6	10-speed SelectShift automatic	375 @ 5,000	470 @ 3,500

AVAILABLE PACKAGE²

Heavy-Duty Trailer Tow Package (536)

Not rated for pursuit.

AVAILABLE FEATURES

4-Wheel-Drive (4WD) System (UIG, K1G [MAX])
 Black running boards (18B)
 Daytime running lamps – Non-configurable (942)
 Engine block heater (41H)

Reverse Sensing System (66R)
 Seat – Cloth 2nd-row 40/20/40 split bench (21B)
 Seat – 3rd-row 60/40 split PowerFold® (deletes 3rd-row storage bins) (87P)

DIMENSIONS & CAPACITIES³

EXTERIOR (in.)		Expedition	Expedition MAX
Length		210.0	221.9
Wheelbase		122.5	131.6
Width	Including mirrors	93.4	93.4
	Mirrors folded	83.6	83.6
Height		76.6 (4x2); 76.4 (4x4)	76.4 (4x2); 76.2 (4x4)
	Minimum running ground clearance	9.8	9.8 (4x2); 9.7 (4x4)
Lift-in height		35.3	34.9
Cargo rear opening height		32.7	32.7
Cargo rear opening width – Lower		51.4	51.4
INTERIOR (in.)			
1st Row			
Head room (max.)		42.0	42.0
Leg room (max.)		43.9	43.9
Hip room		62.2	62.2
Shoulder room		64.9	64.9

INTERIOR (in.)		Expedition	Expedition MAX
2nd Row			
Head room		40.0	40.0
Leg room		41.5	41.5
Hip room		62.6	62.6
Shoulder room		64.8	64.8
3rd Row			
Head room		37.3	37.4
Leg room		36.1	36.1
Hip room		51.4	51.4
Shoulder room		64.2	64.3
CAPACITIES (cu. ft.)			
Cargo volume	Behind 1st row	104.6	121.5
	Behind 2nd row	57.5	73.3
	Behind 3rd row (if equipped)	19.3	34.3
Fuel (gal.)		25.0	30.0
Seating		5, 8	5, 8

TRAILER WEIGHT RATINGS⁴

Hitch Class	Max. Load	
	Expedition	Expedition MAX
4x2 Class IV	9,300 lbs.	9,000 lbs.
4x4 Class IV	9,200 lbs.	9,000 lbs.

Max. weights shown are for properly equipped vehicles with required equipment and a 150-lb. driver. Weight of additional options, equipment, passengers and cargo must be deducted from this weight. For additional information, see your dealer. Cargo and load capacity limited by weight and weight distribution.

EXTERIOR COLORS⁵



INTERIOR COLOR



38 Horsepower, torque and towing are independent attributes and may not be achieved simultaneously.

¹Based on 2020 model-year ratings. ²Visit fleet.ford.com for complete package content. ³Dimensions and capacities shown may vary due to optional features and/or production variability. ⁴Requires Heavy-Duty Trailer Tow Package.

⁵Available on select series. Restrictions may apply. See your dealer for details.

2022 FORD TRANSIT® PTV SPECS



T-250 Cargo Van MR Long Length. Agate Black Metallic. Available and aftermarket upfit equipment.

PRISONER TRANSPORT VEHICLE (PTV)

- Built Ford Tough® lineup can be compartmentalized and customized with heating/cooling, lighting, surveillance cameras and more¹
- Unibody construction with choice of 3 roof heights,² 3 lengths² and 2 powertrains²
- Rear-wheel-drive and all-wheel-drive models available
- Maximum GVWR of 11,000 lbs.^{2,3}
- Flex-fuel capability⁴
- Maximum payload rating of 5,174 lbs.^{2,3}

STANDARD FEATURES

12V powerpoints (2)
 AdvanceTrac™ with RSC® (Roll Stability Control™) with Side-Wind Stabilization
 Alternator – 250-amp
 Auto High-Beam Headlamps
 Door – Sliding passenger-side
 Driver and front-passenger front airbags, front-seat side airbags, and Safety Canopy® System with side-curtain airbags
 Engine – 3.5L PFDi V6 gas
 Flooring – Vinyl front
 FordPass™ Connect⁵ with 4G LTE Wi-Fi hotspot capability⁶
 Forward Collision Warning
 Hill Start Assist
 Lane-Keeping System

Mirrors – Power-adjustable short-arm sideview
 Passenger-side A-pillar grab handle
 Post-Collision Braking
 Pre-Collision Assist with Automatic Emergency Braking (AEB)
 Rain-Sensing Windshield Wipers
 Rear tow hook
 Rear View Camera with Trailer Hitch Assist (MR, HR)
 Remote Keyless Entry System
 SecuriLock® Passive Anti-Theft System
 SOS Post-Crash Alert System™
 Tilt/telescoping steering column
 Tire Pressure Monitoring System (TPMS; excludes spare)
 Transmission – 10-speed SelectShift® automatic with overdrive

ENGINES

3.5L PFDi V6 gas
 3.5L EcoBoost® V6 gas with Auto Start-Stop Technology
 Electric Motor with Single-Speed Transmission (E-Transit)

AVAILABLE FEATURES

3 lengths: Regular, Long and Extended-Length
 3 roof heights: LR, MR and HR⁷
 110V/400W AC power outlet (90D)
 Adaptive Cruise Control including Adjustable Speed Limiting Device (ASLD) (60D)
 Alternator – Dual (63C)
 Autolamp (Automatic On/Off Headlamps) (91B)
 Daytime running lamps (942)
 Decal (up to 15-, 25-, 45-, 70- or 95-sq.-ft.) (51E, 51F, 51G, 51H, 51J)
 Doors – Dual sliding side (MR, HR) (59B)
 Doors – Power-sliding side (MR, HR) (65C)
 DRW (dual rear wheels)
 Engine – 3.5L EcoBoost V6 gas with Auto Start-Stop Technology (99G)
 Engine Idle Shutdown includes Smart Acceleration Truncation (55E, 55F, 55G, 55H)
 Enhanced Active Park Assist (94B)
 Extended-range fuel tank (31 gallons; Long and Extended-Length) (655)
 Flooring – Heavy-duty cargo (60B)
 Heavy-duty front axle (41E)

Lane Departure Warning and aid includes BLIS® (Blind Spot Information System) with Cross-Traffic Alert and Trailer Coverage (65A)
 Orange safety belts (76C)
 Programmable battery guard/enhanced cutoff relay (59C)
 Reverse Brake Assist (43S)
 Reverse Sensing System (43R)
 Side Sensing System (94A)
 Sideview mirrors delete (54X)
 Speed limitation (65-, 70- or 75-mph governed top speed options) (52M, 52H, 52N)
 SYNC® 3 with 4" LCD capacitive touchscreen with AppLink®, 911 Assist® and 2 smart-charging USB ports (58B)
 SYNC 4 with 12" LCD capacitive touchscreen, AM/FM stereo, and embedded voice recognition that includes Connected Navigation, 2 USB ports and 4 front speakers²
 Tow/Haul Mode with Trailer Wiring Provisions (53D)
 Trailer brake controller (TBC) (67D)
 Upfitter interface module (55A)
 Vehicle maintenance monitor including engine-hour meter (61C)

Not rated for pursuit.

AVAILABLE PACKAGES⁸

Ambulance Prep Package (47B)
 Auxiliary Heater/AC Prep Package (62C)
 Auxiliary Heater Prep Package (62A)
 Exterior Upgrade Package (18D/18L)
 Heavy-Duty Scuff Plate Kit (85B)

Heavy-Duty Trailer Tow Package (53B)
 Interior Upgrade Package (96C)
 Load Area Protection Package (96D)
 Scuff Plate Kit (85A)

DIMENSIONS & CAPACITIES⁹

WHEELBASE (in.)	T-150/T-250 SRW Regular 130		T-150/T-250/T-350 SRW Long 148			T-250/T-350 SRW; T-350 HD DRW Extended 148
	LR	MR	LR	MR	HR	HR
Roof height	2	2	2	2	2	2
Passenger capacity	1	1	1	1	1	1
Rows of seats	1	1	1	1	1	1
EXTERIOR (in.)						
Wheelbase	129.9	129.9	147.6	147.6	147.6	147.6
Length	219.9	217.8	237.6	235.5	235.5	263.9
Height	82.2	99.1	82.9	101.3	109.6	110.4
Width – Excluding mirrors	81.3	81.3	81.3	81.3	81.3	81.3; 83.7
Width – Including short-arm mirrors	97.4	97.4	97.4	97.4	97.4	97.4
Width – Mirrors folded	83.2	83.2	83.2	83.2	83.2	83.2
Front track	68.2	68.2	68.2	68.2	68.2	68.2; 68.5
Rear track	68.6	68.6	68.6	68.6	68.6	68.6; 65.7
Front overhang	40.3	40.3	40.3	40.3	40.3	40.3
Rear overhang	49.7	47.6	49.7	47.6	47.6	76.0
Load height (curb)	28.9	28.9	28.7	28.7	28.7	28.0
Side-door opening height	49.6	63.0	49.6	63.0	63.0	63.0
Side-door opening width – 60/40 swing-out	51.2	–	51.2	–	–	–
Side-door opening width – Sliding	51.2	51.2	51.2	51.2	51.2	51.2
Rear cargo door opening height	49.5	64.9	49.5	64.9	74.3	74.3
Rear cargo door opening width	61.7	61.7	61.7	61.7	61.7	61.7
INTERIOR (in.)						
Head room	40.8	52.0	40.8	52.0	56.6	56.6
Leg room (max.)	41.3	41.3	41.3	41.3	41.3	41.3
Hip room	60.7	60.7	60.7	60.7	60.7	60.7
Shoulder room	67.9	67.9	67.9	67.9	67.9	67.9
Cargo length front (at floor)	126.0	126.0	143.7	143.7	143.7	172.2
Cargo length front (at beltline)	115.9	115.9	133.6	133.6	133.6	162.0
Cargo width between wheelhouses	54.8	54.8	54.8	54.8	54.8	54.8; 45.4
Cargo height (max.)	56.9	72.0	56.9	72.0	81.5	81.5
CARGO CAPACITY (cu. ft.)						
Cargo volume behind 1st row	246.7	315.2	277.7	357.1	404.3	487.3

EXTERIOR COLORS²



INTERIOR COLORS²



¹Aftermarket upfit. ²Available on select series. Restrictions may apply. See your dealer for details. ³T-350 HD Cargo Van 3.5L PFDi V6 HR Extended Length DRW. ⁴Available on 3.5L TI-VCT V6 only. Government orders only. ⁵FordPass Connect, the FordPass App, and complimentary Connected Service are required for remote features (see FordPass Terms for details). Connected service and features depend on compatible AT&T network availability. Evolving technology/cellular networks/vehicle capability may limit functionality and prevent operation of connected features. Connected service excludes Wi-Fi hotspot. FordPass App, compatible with select smartphone platforms, is available via download. Message and data rates may apply. ⁶Wi-Fi hotspot includes complimentary wireless data trial that begins upon AT&T activation and expires at the end of 3 months or when 3GB of data is used, whichever comes first, but cannot extend beyond the complimentary subscription period for remote features. To activate, go to www.att.com/ford. ⁷High Roof not available on Transit 150. ⁸Visit fleet.ford.com for complete package content. See your dealer for details. ⁹Dimensions and capacities shown may vary due to optional features and/or production variability. Cargo and load capacity limited by weight and weight distribution. ¹⁰Fleet only.



Front Headlamp Lighting Solution (66A). Includes base headlamps with LED high- and low-beam wig-wag function and LED side warning lights (driver side red/white; passenger side blue/white).



Side marker LED lamps – Rear quarter glass (63L). Features backlit flashing, linear high-intensity LED lamps.



Side marker LED lamps – Sideview mirror (63B). Features backlit flashing, linear high-intensity LED lamps.



Taillamp Lighting Solution (66B). Includes halogen base lamps, plus (2) integrated hemispheric lighthouse LED side warning lights.



Rear Lighting Solution (66C). Includes (2) backlit flashing, linear high-intensity LED lights (driver side red; passenger side blue) with surround cover mounted inside the liftgate glass. **Police liftgate lights.** Features (2) backlit flashing, linear high-intensity LED lights (driver side red; passenger side blue) mounted inside the liftgate lip; lights activate when liftgate is open.



Front warning auxiliary lamps (21L). Features integrated, custom-designed LED assemblies.



Front Interior Visor Light Bar (96W). Includes (2) backlit flashing, linear high-intensity LED lights (driver side red; passenger side blue) mounted inside the windshield glass. Lights can be programmed for tricolor (red, white, blue) patterns.



Rear auxiliary liftgate lights (43A). Features backlit flashing, linear high-intensity LED lights (driver side red; passenger side blue) mounted just above the license plate.



Rear spoiler LED traffic warning lights (96T). Includes (2) backlit flashing, linear high-intensity LED lights (driver side red; passenger side blue) mounted on the edge of the rear spoiler. Lights can be programmed for tricolor (red, blue, amber) patterns; also features amber-only traffic direction mode.





READY-FOR-THE-ROAD PACKAGE

Available on Ford Police Interceptor[®] Utility (67H)²

- A.** Front Headlamp Lighting Solution
- B.** Grille LED lights
- C.** Taillamp Lighting Solution
- D.** Rear Lighting Solution
- E.** Front console mounting plate
- F.** Rear console plate
- G.** Hidden door-lock plungers/rear door handles inoperable
- H.** Control system
- I.** 100-watt siren/speaker

Whelen[®] CenCom relay center/siren/amp with Traffic Advisor

Light controller/relay CenCom wiring (wiring harness) with additional input/output pigtails

High-current pigtail

Whelen specific WECAN cable connects CenCom to control head

Pre-wiring for grille LED lights, siren and speaker

Overlay wiring harness, grille LED lights, siren and speaker wiring, and control power harness



POLICE INTERIOR UPGRADE PACKAGE

Available on Police Interceptor Utility (65U)

Cloth rear seat – Heavy-duty fabric

Center floor console – 2 cupholders and unique finish

Front and rear floor mats – Carpeted and custom-fit

Front and rear carpeted floor covering – Premium-grade

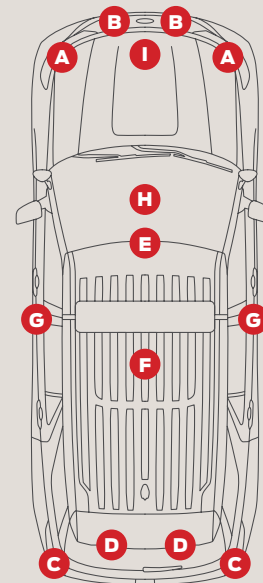

Front Headlamp Lighting Solution. Includes base headlamps with high-beam wig-wag function and (2) LED side warning lights (driver side red/white; passenger side blue/white).



Grille LED lights. Includes (2) backlit flashing linear high-intensity LED lights (driver side red; passenger side blue).

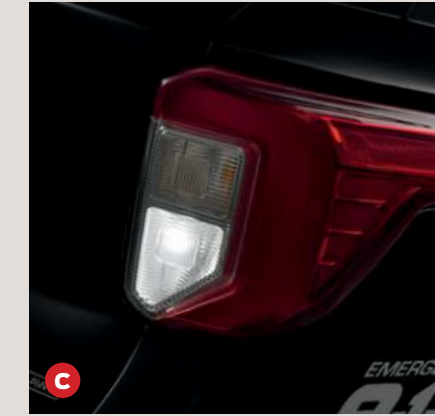

Taillamp Lighting Solution. Includes halogen base lamps and (2) integrated hemispheric lighthouse white LED marker lights.

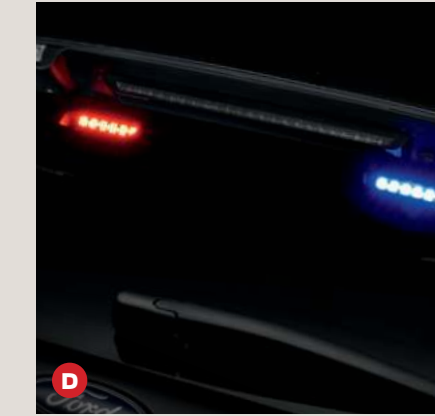

Rear Lighting Solution. Includes (2) backlit flashing, linear high-intensity LED lights (driver side red; passenger side blue) with surround cover mounted inside the liftgate glass and (2) backlit flashing, linear high-intensity LED lights mounted inside the liftgate lip.

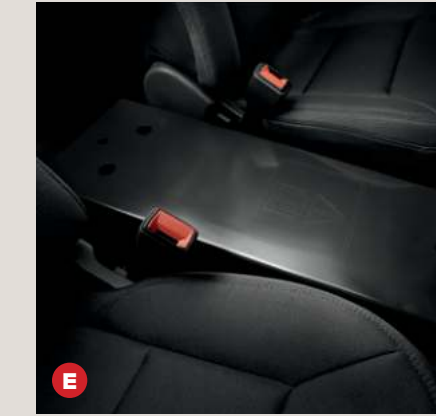

Front console mounting plate. Solid foundation for attaching aftermarket equipment and channeling wiring. Measures 9" wide, with 11" between the driver and front-passenger seats.



Rear console plate. Interfaces with front console mounting plate and extends through 2nd-row occupant area to seat bottom (acting as wiring conduit on top of transmission tunnel).

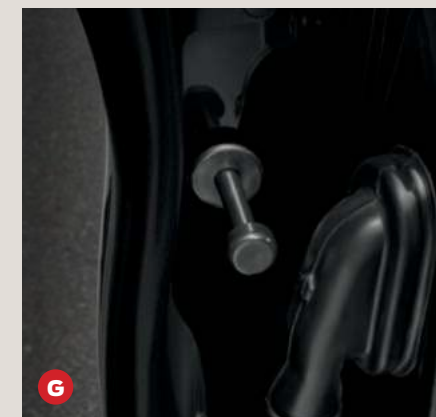

Hidden door lock plungers. Manual lock rod with inoperable rear door handles.

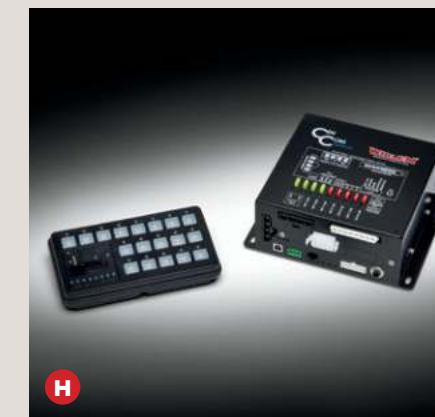

Control system. Includes CenCom controller, control head, and wire.



100-watt siren/speaker. Includes wire.

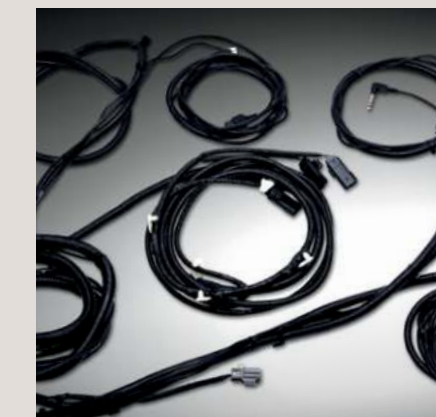

Wiring harness. Includes (2) light connectors that support up to (6) LED lights each (engine compartment); (2) grille LED light connectors; and (1) 10-amp siren/speaker circuit (engine to cargo area).

Confidence in the capability of police equipment authorized by Ford. Components and installations are verified through the comprehensive Ford Quality System for exacting evaluation in terms of crash testing, cycle testing, vibration testing, hot/cold testing, humidity testing, corrosion testing and the like.

STAND-ALONE OPTIONS

Available on Ford Police Interceptor® Utility

- A. Auxiliary air conditioning (17A)** – Offers climate control for the rear cargo area
- B. Cargo area storage vault (63V)** – Lockable and ideal for contraband/small arms; located on the driver’s side of the cargo area
- C. Rear console plate (85R)** – Interfaces with front console mounting plate and extends through 2nd-row occupant area to seat bottom; acting as wiring conduit on top of transmission tunnel
- D. Hidden door lock plungers (52P)** – Manual lock rods; rear door controls inoperable
- E. LED Spot lamp with swivel mount (51R/51T)** or driver and passenger (51S/51V)
- F. Rear quarter glass side marker LED lamps¹ (63L)** – Wide-angle, backlit flashing, linear high-intensity
- G. Sideview mirror side marker LED lamps¹ (63B)** – Backlit flashing, linear high-intensity
- Ultimate Wiring Package (67U)** – Includes rear console mounting plate; pre-wiring for grille LED lights, siren and speaker; and much more
- OBD-II Split Connector (61B)** – Allows up to 2 devices to be connected to the OBD-II port
- Pre-wiring for grille lamp, siren and speaker²** – Electrical harness inlay (14290) includes: (2) light connectors that support up to (3) LED lights each (in engine compartment), (1) grille LED light connector that supports (2) LED lights, and (1) front driver’s side speaker siren cable (not shown)

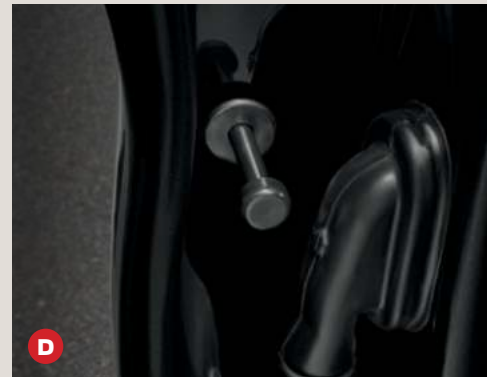
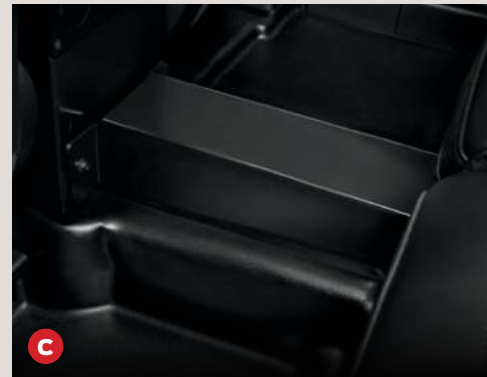

VSO provides special paint and equipment options that are not currently available through regular – fleet-only – production. VSO offers a means of creating customized solutions that can meet the unique requirements of your force.

VSO color and equipment availability.³ VSO can provide a variety of unique paint finishes. In addition, VSO lighting packages and options – such as those listed at right – offer a distinctive appearance and help ensure adherence to state law requirements.

New option development (VSO inquiries). Establishing new VSO options is initiated by a customer request called a “VSO inquiry.” Your dealer representative will submit the VSO inquiry. All requests are received, reviewed and approved by the VSO department to ensure the end product is compatible with regular and limited options. The end product must also meet Ford Motor Company standards of quality, durability, safety and performance.

Production timing. If you add existing VSO options to your vehicles, the process takes 60-90 days to go from order receipt to production. For newly created VSO options, please include the development timing provided within the inquiry response. For your fleet-planning purposes, VSO production typically begins a month after Job One and balances out a month prior to Job Last.

To help you plan better, please visit fleet.ford.com/orders/vehicle-special-order before ordering, to view the most current VSO options.

VSO EXTERIOR COLORS

- Red
- Tan
- Green
- Silver-Gray

SAMPLE VSO POLICE LIGHTING OPTIONS

- Grille lights – Red/red or blue/blue
 - Rear lights – Red/red or blue/blue
 - Front marker lights – Red/red, blue/blue or red/blue split (red-white/red-white, blue-white/blue-white and white/white options)
 - Front warning auxiliary lights – Red/red or blue/blue
 - Sideview mirror side marker lights – Red/red or blue/blue
 - Taillamp warning lights – Red/red, blue/blue or red/blue split
 - Rear auxiliary liftgate lights – Red/red or blue/blue
 - Rear quarter glass side marker lights – Red/red or blue/blue
- Visit fleet.ford.com/orders/vehicle-special-order for order codes, pricing and details.

SMART FUNDING

Many public agencies are discovering that Municipal Lease/Purchase Financing is today's answer to acquiring essential equipment within limited budget confines – without major cash outlays, long-term debt obligations or, in most cases, voter approval.



HERE'S HOW IT WORKS

- Fixed-rate financing helps you get the vehicles you need when you need them, while sticking to your current budget
- Flexible repayment terms – monthly, quarterly, semiannually and annually
- Finance add-on equipment, upfits and extended-warranty plans
- Equity is accumulated with each payment, and ownership is realized with a final payment of \$1

FOR YOUR BENEFIT

- Avoid high costs of maintaining older equipment
- Tax-exempt interest rates
- No down payment or security deposit required
- No mileage restrictions
- No maintenance or return provisions
- Access to the latest technologies

WE'RE HERE FOR YOU – JUST CALL 1.800.241.4199

- If you have any questions, call and speak to a Ford Credit Marketing Coordinator
- Let our team help you acquire the equipment you need – when you need it
- We can provide you with a payment quotation quickly so you can make a timely decision and focus on what's important: your municipality
- Visit us online at <https://www.ford.com/finance/commercial-financing/municipal>

Ford Motor Credit Company ("FMCC") is providing the information contained in this document for discussion purposes only in connection with a proposed arm's length commercial leasing transaction between you and FMCC. FMCC is acting for its own interest and has financial and other interests that differ from yours. FMCC is not acting as a municipal advisor or financial advisor to you, and has no fiduciary duty to you. The information provided in this document is not intended to be and should not be construed as "advice" within the meaning of Section 15B of the Securities Exchange Act of 1934 and the municipal advisor rules of the SEC. FMCC is not recommending that you take an action and you should discuss any actions with your own advisors as you deem appropriate.

HOW MUCH EQUIPMENT CAN YOU GET FOR \$150,000?¹

Option A: Purchase Today for Cash



Option B: Ford Credit Municipal Lease/Purchase Financing



FORD PROTECT™ IS AVAILABLE FOR ALL FORD SPECIAL SERVICE VEHICLES

Upgrade your protection: Select the extended warranty that best suits your needs. There are 4 plans available that wrap around or extend the powertrain warranty – PowertrainCare, BaseCare, ExtraCare, PremiumCare – with comprehensive coverage for up to 8 years and 150,000 miles on new vehicles. In addition, drop-off first-day rental is included on all plans.



FORD COLLISION PARTS

Dependability is crucial. To do your job, you depend on every piece of your equipment to function as it was designed. The same goes for your police unit, and if you're ever in an accident, you can depend on Ford Collision Parts: sheet metal, bumpers and lights to help restore your vehicle to pre-accident condition. Ford Collision Parts are equal in quality, fit and structural integrity to the original parts that came on your vehicle because they are the same parts used in the production of new vehicles. Designed, engineered, and produced by Ford Motor Company to meet Federal Motor Vehicle Safety Standards. Cheap imitation parts can't make that claim. So don't settle for anything less dependable than Ford Collision Parts.



FORD FLEET CARE

Ford Fleet Care is a centralized billing service you can use to make a single monthly payment on behalf of your entire fleet for maintenance and repairs performed at participating Ford Dealers and Quick Lane® Tire & Auto Centers. Over-the-counter parts purchases at participating Ford Dealers can also be included. There is no enrollment fee, no per-vehicle fee and no administration fee for warranty-covered repairs. Plus, you preset your drivers' spending limits, which cannot be exceeded without your approval. Visit fleetcare.ford.com or call **1.800.367.3221** for more information.

An industry first. Acting as a liaison and resource for law-enforcement agencies nationwide, the Elite Police Advisory Board provides frank and direct feedback on the products, programs and policies of Ford. These standout officials help refine current vehicles and create future offerings. Input on safety, reliability and durability is essential to serving unique operational needs, and proves invaluable to the ongoing development of Ford law-enforcement vehicles. Please visit fleet.ford.com for more PAB specifics.



Dirk Aubuchon
Los Angeles Police Department
g9546@lapd.online
213.486.1020



Darrell Cooper
City of Kansas City, MO
darrell.cooper@kcmo.org
816.513.6931



Dominic Martinez
Albuquerque Police Department
dpmartinez@cabq.gov
505.917.6905



Art Thompson
City of Detroit
thompsona554@detroitmi.gov
313.920.4955



Stacy Barr
California Highway Patrol
stbarr@chp.ca.gov
916.309.6800



PJ Fernandes
Massachusetts State Police
paul.fernandes@state.ma.us
508.820.2665



Michael J. McCarthy
Michigan State Police
mccarthym4@michigan.gov
517.230.3184



Daren Turner
Las Vegas Metro
Police Department
d6573t@lvmpd.com
702.828.3319



Brad Brewer
Hendon Publishing
Police Fleet Manager Magazine
sgt1411@gmail.com
778.839.1411



Robert Furman
Los Angeles County Sheriff's
Department
rffurman@lasd.org
323.881.3982



Scott G. Newsome
City of Charleston
Police Department
newsomes@charleston-sc.gov
843.509.2414



Eric Voll
City of Columbus, Ohio
ervoll@columbus.gov
614.645.6218



Jennifer (Jen) Brown
Coconino County Sheriff's
Department
jbrown@coconino.az.gov
928.226.5115



Jason Halayko
Edmonton Police Service
jason.halayko@edmontonpolice.ca
780.421.2116

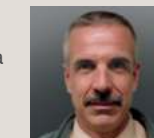

Scott Olexa
New York City Police Department
scott.olexa@nypd.org
718.476.7588



Vincent Brown
City of Fort Worth
vincent.brown@fortworthtexas.gov
817.392.4312



David (Doc) Halliday (ret.)
Michigan State Police
dhalliday430@gmail.com
517.256.3689



Robert Phillips
Howard County
roPhillips@howardcountymd.gov
410.313.0723



Michael Carkido
Boardman Police Department
mcarkido@boardmantwp.com
330.726.4144



Jonathan Hickel
City of Alpharetta
jhickel@alpharetta.ga.us
678.758.2274



Gerrick Provencio
Arizona Department of Public
Safety
gprovencio@azdps.gov
602.223.2349



Andrés Casimiri
Royal Canadian
Mounted Police (RCMP)
andres.casimiri@rcmp-grc.gc.ca
613.843.3429



Carl Huse
Mississippi Highway Patrol
chuse@comcast.net
601.940.0099



Kevin Rausis (ret.)
San Diego Police Department
the2krs@cox.net
619.993.6506



HERE TO SERVE YOU

GOVERNMENT SALES REGIONAL MANAGERS

Dan Mazurek
Northeast States:
CT, DE, MA, MD, ME, NH, NJ, NY, PA, RI, VT
313.407.2973 • dmazure1@ford.com

James Morgan
Southeast States:
AL, FL, GA, NC, SC, TN, VA
901.230.0125 • jmorga12@ford.com

Chris Keady
North Central States:
IA, IL, IN, KY, MI, MN, OH, WI, WV
313.595.4691 • ckeady@ford.com

Stacy Padilla
South Central States:
AR, KS, LA, MO, MS, OK, TX
214.497.0214 • smerrill@ford.com

Scott Clark
Western States:
AK, AZ, CO, MT, ND, NE, NM, SD, UT, WY
801.808.4982 • sclark10@ford.com

Steve Hoe
Western States:
CA, HI, ID, NV, OR, WA
916.705.5350 • shoe@ford.com

GOVERNMENT SALES MANAGER

Tony Gratson
313.390.1041 • tgratson@ford.com

STATE & LOCAL GOVERNMENT SALES MANAGER

Ron Anderson
313.390.1058 • randers1@ford.com

VEHICLE SPECIAL ORDER (VSO) SALES COORDINATOR

Cale Kehoe
VSO Coordinator
313.390.0855 • ckehoe1@ford.com

FEDERAL GOVERNMENT SALES MANAGER

Debra Hairston
313.390.1095 • dhairsto@ford.com

MUNICIPAL BUSINESS DEVELOPMENT MANAGERS

Jessica Olson
CT, DE, ME, MD, MA, NH, NJ, NY,
PA, RI, VT
313.594.1825 • jgunn26@ford.com

Janet Doty
AL, FL, GA, IN, KY, MI, MS, NC, OH, SC,
TN, VA, WV
313.390.7184 • jdoty@ford.com

Thomas O'Donnell

AK, AZ, AR, CA, CO, HI, ID, IL, IA, KS, LA,
MN, MO, MT, NE, NV, NM, ND, OK, OR,
SD, TX, UT, WA, WI, WY
313.845.7894 • todonne8@ford.com

FORD CREDIT MUNICIPAL FINANCE PROGRAM

1.800.241.4199 (Press 1)

FORD FLEET CUSTOMER SERVICE

Fleet Customer Information
Center (FCIC):
1.800.34.FLEET (U.S.)
1.800.668.5515 (CANADA)

Open 8:30 AM – 5:00 PM EST

Choose from the following selections:
• FIN Enrollment/Website (Press 1)
• Fleet Sales/Order-to-Delivery (Press 2)

The FCIC supports Fleet Accounts by
providing a single source to answer all of
your Fleet-related questions.

FORD POLICE MODIFIERS GUIDES

fordbbas.com/publications
Call Center: 877.840.4338

FORD FLEET

North American Commercial Business

fleet.ford.com • 1.800.34.FLEET

Non-original equipment can adversely impact vehicle crash performance. For example, push-bars could adversely affect airbag deployment in frontal impacts, and prisoner barricades could result in head and neck trauma in high-speed rear impacts. Due to the variability of equipment installed, based on individual law-enforcement agency requirements, Ford does not test aftermarket equipment for functionality with Ford components. Law enforcement must balance needs for function and other officer safety concerns when equipping police vehicles with non-original equipment.

Some features discussed may be optional. Vehicles throughout this brochure may be shown with optional features and/or aftermarket equipment. Features shown may be offered only in combination with other options or subject to additional ordering requirements or limitations. Information in this brochure was developed from Order Guides as of May 2021. Following publication of this brochure, certain changes in standard equipment, options and the like, or product delays may have occurred which would not be included in these pages. • Always wear your safety belt, secure children in the rear seat and follow airbag warning label instructions. • SYNC³: Don't drive while distracted or while using handheld devices. Use voice-operated systems when possible. Some features may be locked out while the vehicle is in gear. Not all features are compatible with all phones. • For more information, visit fleet.ford.com. • Ford Motor Company reserves the right to change product specifications at any time without incurring obligations. Comparisons based on competitive models, publicly available information and Ford certification data at time of printing. • Ford and Oval Device, 911 Assist, AdvanceTrac, AppLink, BLIS, BoxLink, Built Ford Tough, CenterSlide, Easy Fuel, EcoBoost, EcoSport, Edge, Escape, Expedition, Explorer, F-150, F-Series, Ford Co-Pilot360, Ford Data Services, Ford Protect, Ford Telematics, FordPass, FX4, Hill Descent Control, Mustang, Mustang Mach-E, MyKey, Personal Safety System, Police Interceptor, Police Responder, Power Stroke, PowerBoost, PowerFold, Pro Trailer Backup Assist, Quick Lane, Roll Stability Control, RSC, Safety Canopy, SecuriCode, SecuriLock, SelectShift, SOS Post-Crash Alert System, STX, SuperCrew, SYNC, Tough Bed, Transit, Transit Connect and related marks are trademarks of Ford Motor Company. • Apple CarPlay is a trademark of Apple Inc., registered in the U.S. and other countries. • Android Auto is a trademark of Google LLC. • King Ranch is a registered trademark of King Ranch, Inc. • The Bluetooth word mark is a trademark of the Bluetooth SIG, Inc. • Torque-On-Demand is a registered trademark of BorgWarner. • Unity is a registered trademark of Unity Manufacturing Co. • Whelen is a registered trademark of Whelen Engineering Co., Inc.

