

RENAULT TRAFIC



DRIVE THE CHANGE



THE RENAULT CUSTOMER CARE PACKAGE: YET ANOTHER OF THE PLEASURES OF RENAULT OWNERSHIP

Today's Renault vans testify to the enormous technological advances made over the past decade and demonstrate the benefits which those advances have brought to the motorist. The modern Renault performs powerfully, uses less fuel and is safer than ever before. Equally important, it is durable and reliable - a fact which is reflected in the comprehensive warranty package enjoyed by every Renault owner. All Renault vans come with 5 years warranty and AA Roadside Assist. Paintwork is also guaranteed for 3 years while the anticorrosion warranty runs for 12 years.

A COMPREHENSIVE RANGE OF PRACTICAL, HELPFUL SERVICES

Renault Roadside Assistance. The support you get in the 5 years of owning your new Renault is enhanced by free Renault Assistance cover. The Renault Assistance team is there for the sole purpose of responding to emergency calls from Renault customers, so you can be assured of top class service. Your handbook will give a complete rundown of all the help and services available to you, but, briefly, they include: Roadside Assistance: if you breakdown or your van is immobilised, at any time of day or night, one free phone call will bring help. Recovery: if you can't be fixed by the side of the road, your vehicle will be recovered to the nearest Renault dealer and you will be offered an alternative form of mobility, if need be. At home: you don't have to be out and about to get help. The Assistance provider will attend a breakdown at your home or office as well.

SERVICES AVAILABLE FROM YOUR RENAULT DEALERSHIP

Superior vans – superior service. Renault is represented by a nationwide network of dealers, so you can be sure that you're never far from experts who can help you get the very most from ownership of your new van. Renault workshops are equipped with the very latest in diagnostic and other equipment to keep your van operating at peak efficiency. Your dealer's parts department houses a huge range of electrical and mechanical parts, so repair or servicing operations are not delayed by the lack of vital parts. Your local dealer is the first point of contact for anything and everything concerned with your new Renault - including, of course, a test drive!

The best accessory shop in town is at your Renault dealer. If you've looked at the specification lists in this brochure, you won't need to be told that Renault vans are amazingly well equipped. But Renault owners are individuals with their own individual tastes, needs and interests. Which is why the Renault Boutique at Renault dealerships offers a wide range of additional equipment and accessories. There are tow bars, wood protection, roof racks, roof bars, and much more besides. Every single item is made to the same quality standards as the components used in Renault vans themselves and is a perfect match for Renault's distinctive visual style.

FINANCE AVAILABLE FROM RENAULT

Renault Finance has arrived, offering a full range of financial services that will enable you to purchase or lease, and protect the Renault of your choice. We offer competitive and flexible finance packages aimed at you, the Renault customer. We are part of one of Europe's largest motor finance companies and service millions of customers everyday. Drop down to your local dealer today to find out more about our latest offers or visit www.renault.ie

WHO BETTER THAN RENAULT TO SERVICE YOUR RENAULT?

CUSTOMER RELATIONS SERVICES

Renault knows the value of communicating with its customers and we have established effective ways of keeping in touch with you.

Whatever your query you can contact Renault Ireland Customer Services Department on LoCall **1890 771 771**

You can also visit us on the Internet at www.renault.ie, on www.facebook.com/renaultireland and on www.twitter.com/renaultireland

Or write to us at: **Renault Ireland,**
Customer Services Department,
Dundrum Retail & Office Park,
Level 6, Block 4,
Dundrum, Dublin 16



Paralympics
IRELAND

Proud supporter of the Irish Paralympic Team



FOR 115 YEARS, WE HAVE ALWAYS COMMUNICATED THE VIEW THAT FOR A VEHICLE TO BE IN TUNE WITH THE TIMES, IT HAS TO BE INNOVATIVE, MAKE A RESPONSIBLE COMMITMENT, AND INSPIRE PASSION WHILE OFFERING SUSTAINABLE MOBILITY FOR ALL.

Our relationship with drivers and their passengers is founded on one simple idea: for a car to be popular, it has to be practical, reliable and suited to the lifestyle and expectations of each individual. This is why Renault offers general models, - cars for living -, accessible for everyone. From the first standardised models in the beginning of the 20th century, to the upcoming launch of the first range of electric vehicles, our aim has always been to make the motor car and mobility available to as many people as possible. Today, we are convinced that another world is possible; a world where the automobile is no longer a threat to the environment but instead combines mobility, safety and quality - for everyone. We assert this vision every day, never losing sight of the fact that passion for motoring is, and will always be, what drives us forward. We want to bring new meaning to the automobile, so that it can take a different, more appropriate position with regard to social issues and so that it will always remain a sign of progress for Mankind. The Renault vehicles for today and for the future are the founding stones of our ambition to offer sustainable mobility to all.

RENAULT. DRIVE THE CHANGE.

RENAULT
eco²

RENAULT
Z.E.

5
YEARS
UNLIMITED
MILEAGE
WARRANTY

MODERN AND ECONOMICAL, RENAULT TRAFIC ADAPTS TO ALL YOUR NEEDS

5
YEARS WARRANTY
UNLIMITED
MILEAGE

For your peace of mind, all RENAULT commercial vehicles are covered by a comprehensive warranty for 5 years without any mileage limitation.

RENAULT Finance

Once you will have chosen the van that best suit your needs,
RENAULT Finance will help you to drive away with it.





Trafic has been specifically designed to meet the needs of professionals, whatever their business area. Trafic adapts to each of your requirements, offering you a wide range of bespoke commercial vehicle solutions. With its stylish and protective design, quiet performing engines, the latest on-board technology and high levels of comfort and safety, the Trafic holds every advantage!

TRAFIC PANEL VAN

IT TAKES CARE OF EVERYTHING.



We have made the Panel Van range as extensive as possible to be close to your professional requirements. Whatever the load, from delicate plants to heavy parcels, large or small, you will find the Traffic that suits you. A choice of two lengths, two heights and two gross vehicle weights enabling access to most underground car parks, with a practical, easy-in-and-out loading area... so many solutions to meet every business needs.



TRAFIC CREW CAB

COMFORT AND PRACTICALITY.

The Traffic Crew Cab provides up to six seats. The loading area is really practical, a glazed bulkhead separates cabin from load. Inside, passengers travel with total peace of mind and under the best safety conditions.





AN AREA OF WELL-BEING

ERGONOMIC, FOR PROFESSIONAL COMFORT



Traffic optimizes your professional environment thanks to a complete range of equipment. Enjoy the benefits of Air conditioning** and save time on your journeys thanks to the reliability of the Carminat TomTom® LIVEnavigation system*. Keep cabin space calm and well organized with a storage compartment for the navigation remote control and the new A4 dashboard compartment that holds your documents. The storage pockets in the middle of the dashboard make best use of all the free space available. A cruise control/speed limiter manages your fuel consumption. The radio range offers Bluetooth® technology and connectivity to your mobile devices**.

* Available as option ** As standard on Executive



DIESEL 2.0 DCI ENGINE

INCREASED PERFORMANCE, REDUCED FUEL CONSUMPTION.

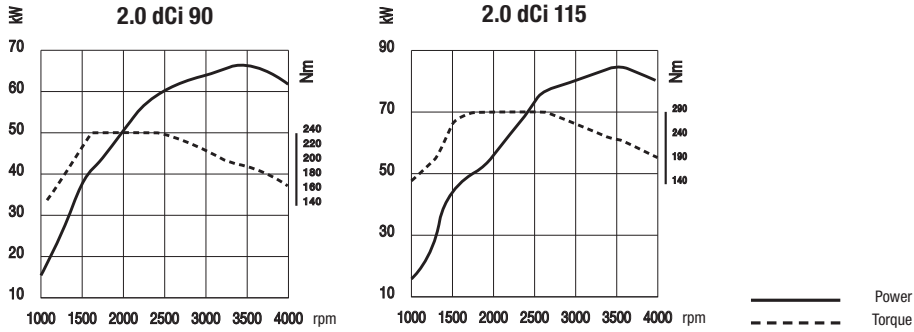

A complete range of engines enables Traffic to meet all requirements. They combine smooth and quiet running to deliver an excellent performance to fuel economy ratio. All engines comply with the Euro 5 standard. Renault also offers approved fleets dCi 90 and 115 engines compatible with "B30" biodiesel.



OPTIMAL SAFETY

WITH TRAFIC, YOU'RE IN A SAFE PLACE.

For any professional, safety on the job is an absolute must. To guard against everyday hazards, the Trafic is fitted (as standard or optional), with some truly innovative systems: windscreen wipers with rain sensor, automatic headlamps and automatic door locking when you are on the move (3). To help you keep control in even the toughest conditions, Trafic uses specially developed technologies to counter difficult driving situations. These include ABS brakes coupled with EBD (Electronic Brake Distribution) (2), Brake Assist, adjustable dynamic ESP (Electronic Stability Programme) driving control with load adjustment (1), cruise control/ and speed limiter. Finally, to protect driver and passengers, Trafic offers full safety measures: front, airbags and 3-point height adjustable seat belts with load limiter and pre-tensioners (4).

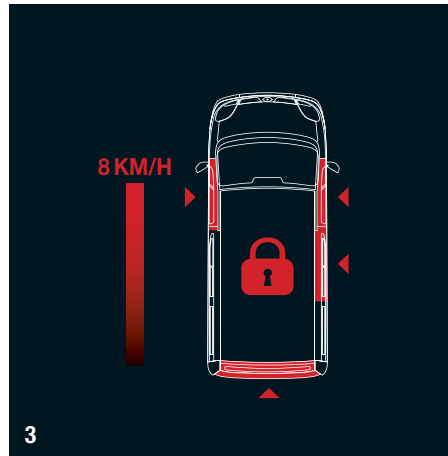
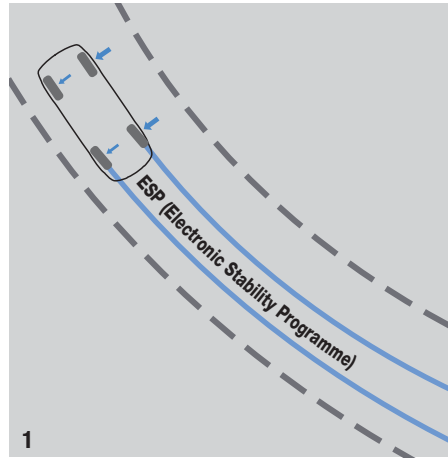

DIMENSIONS, WEIGHTS & LOADS

LOW ROOF - PANEL VANS

SL-SWB LOW ROOF

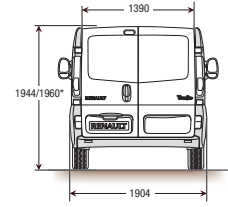
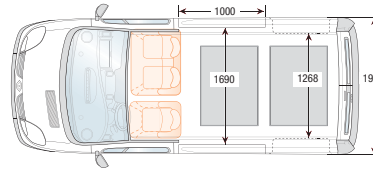
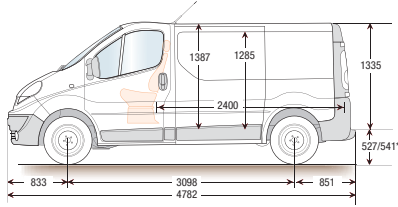

LL-LWB LOW ROOF

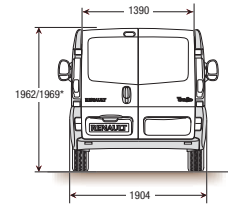
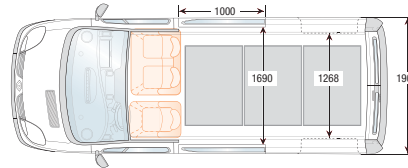
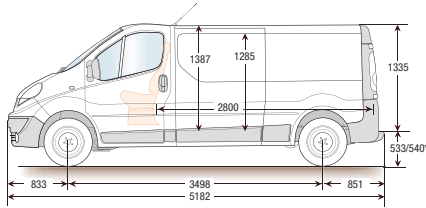

Dimensions (mm)	SL		LL
	2.7t / 2.9t	2.9t	2.9t
Variants			
Load length x Width x Height	2,400 x 1,690 x 1,387	2,800 x 1,690 x 1,387	2,800 x 1,690 x 1,387
Load volume (m ³)	5	5.9	-
Wheelbase	3,098	3,498	3,498
Width x height of side doors	1,000 x 1,285	1,000 x 1,285	1,000 x 1,285
Width x height of rear doors	1,390 x 1,335	1,390 x 1,335	1,390 x 1,335

Payloads (kg)	Manual			Robotized
	2.0 dCi 90	2.0 dCi 115	2.0 dCi 115	2.0 dCi 115
Variants				
SL27 - SWB Low Roof 2.7t	1,080	1,080	1,080	-
SL29 - SWB Low Roof 2.9t	-	1,240	1,240	-
LL29 - LWB Low Roof 2.9t	1,282	1,282	1,282	1,193

HIGH ROOF - PANEL VANS

LH-LWB HIGH ROOF

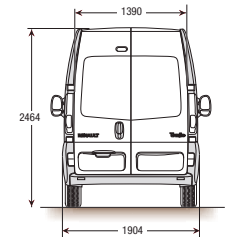
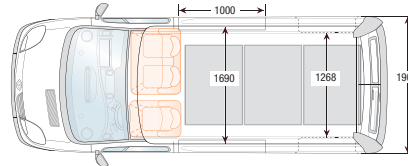
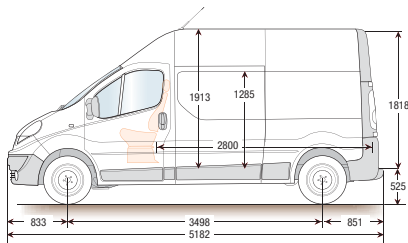

Dimensions (mm)	LH
	2.9t
Variants	
Load length x Width x Height	2,800 x 1,690 x 1,913
Load volume (m ³)	8.3
Wheelbase	3,498
Width x height of side doors	1,000 x 1,285
Width x height of rear doors	1,390 x 1,818

Payloads (kg)	Manual			Robotized
	2.0 dCi 90	2.0 dCi 115	2.0 dCi 115	2.0 dCi 115
Variants				
LH29 - LWB High Roof 2.9t	-	1,197	1,197	-

DIMENSIONS WEIGHTS & LOADS

CREW CAB

LL-LWB LOW ROOF

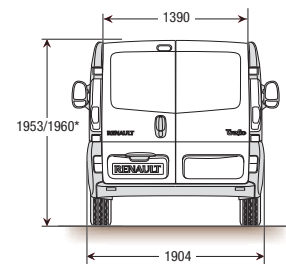
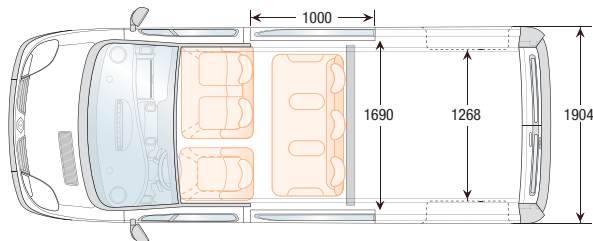
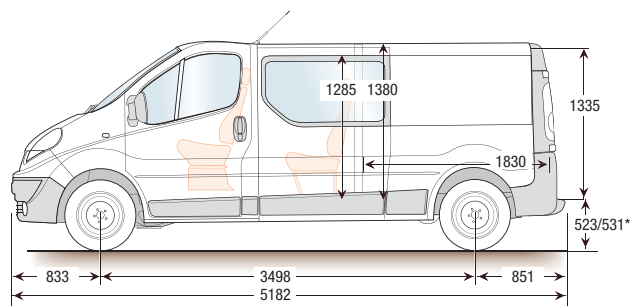

Dimensions (mm)

	LL
Variant	2.9t
Load length x Width x Height	1,830 x 1,380
Load volume (m³)	4.13
Payload	1,004
Width x height of rear doors	1,390 x 1,335
Useful floor length with bench seat folded	2,8

COMFORT AND TECHNOLOGY

1. RADIO-CD BLUETOOTH® PLUG&MUSIC USB

You can benefit from USB connection via radio. Equipped with Bluetooth function, the radio allows you to listen to music with a real quality sound, ensuring quality audio and has the additional safety benefit to make and receive handsfree mobile calls.



2. CARMINAT TOMTOM® LIVE

With calculation of the best route, real time traffic information and fixed speed camera warnings, all information is attractively displayed on the large colour screen which swivels to face the driver. This equipment saves time and reduces your fuel consumption.



3. TRIP COMPUTER

Indicates the journey parameters (distance travelled, average speed, total, average and current fuel consumption and forecast fuel range).



4. MANUAL AIR-CONDITIONING

ACCESSORIES

1.2.3.4. TOW BARS

Choosing a tow bar is decisive for quality and safety. Renault does not stop with the strictest European standards (EC 94/20). Thanks to additional tests, Renault also ensures that your vehicle will not be damaged by intensive professional use. Finally, Renault also takes into account the hardest climatic conditions, applying an anticorrosion treatment.

5. ROOF BARS

These steel bars can receive a load of 50kg per rail.

6. STEEL LADDER & ROOF RACK

The ladder fits on the rear door of your Traffic. It helps you to load items onto the roof rack. The roof rack is equipped with a rear sliding roller to aid loading. Walkway is also available



1



2



3



4



5



6



7

7. ENTIRE WOOD PROTECTION

Protect the loading area of your new Traffic when transporting merchandise.

COLOURS



WHITE (D31)*



LAVENDER BLUE (V489)*



PANORAMA BLUE (J43)**



STORM BLUE (D47)**



LASER RED (C70)*



LIGHTNING SILVER (G64)**

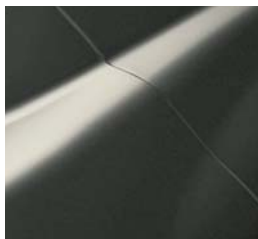

TOPAZ (C66)**



BLACK (D68)**

*: Non-metallic paint; **: Metallic paint.

UPHOLSTERY AND WHEELS



1



2



3

1. VINYL UPHOLSTERY (as an option)
2. GALATONE (as standard on Business)
3. ELBA GREY (as standard on Comfort & Executive)



1



2



3

1. Small wheel caps (as standard on Comfort)
2. Large wheel trims (as standard on Executive)
3. 16" alloy wheels (as an option)

TECHNICAL FEATURES

ENGINES	2.0 dCi 90 FAP Manual	2.0 dCi 115 FAP Manual	2.0 dCi 115 FAP Robotized
Capacity (cm ³)/Number of cylinders/valves	1,996/04/16	1,996/04/16	1,996/04/16
Peak power kW CEE (bhp) at rpm	66 (90)/3,500	84 (115)/3,500	84 (115)/3,500
Peak torque Nm CEE at rpm	260/1,500	300/1,500	300/1,500
Type of injection	Common rail + fixed geometry turbo		
Emission control standard/Catalytic converter/Particulate filter	Euro 5	Euro 5	Euro 5
Ø turning circle between kerbs/walls (m)	Short wheelbase: 11.84/12.40 Long wheelbase: 13.7/13.73		
PERFORMANCE			
Top speed (km/h)	150	150	150

Vehicle configuration: excluding options, without driver, with fluids and tooling						Fuel consumption (Directive 93/116/EC)				WEIGHTS	
	GVW (t)	Wheelbase	Roof	Engine type	Number of seats	CO ₂ emissions (g/km)	Urban conditions (l/100 km)	Extra-urban conditions (l/100 km)	Mixed conditions (l/100km)	Gross train weight (GTW)	Max. payload (kg)
PANEL VAN	2.7t	SWB	Low Roof	2.0 dCi 90 Manual FAP	2/3	204	9.1	7	7.8	4,790	1,080
	2.7t	SWB	Low Roof	2.0 dCi 115 Manual FAP	2/3	204	9.1	7	7.8	4,790	1,080
	2.9t	SWB	Low Roof	2.0 dCi 115 Manual FAP	2/3	204	9.1	7	7.8	4,950	1,240
	2.9t	LWB	Low Roof	2.0 dCi 90 Manual FAP	2/3	207	9.2	7.1	7.9	5,030	1,282
	2.9t	LWB	Low Roof	2.0 dCi 115 Manual/Robotized FAP	2/3	207	9.2	7.1	7.9	5,030	1,282
	2.9t	LWB	High Roof	2.0 dCi 115 Manual FAP	2/3	207	9.2	7.1	7.9	5,030	1,197
CREW CAB	2.9t	LWB	Low Roof	2.0 dCi 115 Manual FAP	2/3	207	9.2	7.1	7.9	5,005	1,197

EQUIPMENT AND OPTIONS

	PANEL VAN & CREW CAB		
	Business *	Comfort	Executive **
EXTERIOR			
Front & Rear bumpers	●	●	●
Side protection strips	●	●	●
Small wheel caps	-	●	-
Maxi wheel trims	-	-	●
16" alloy wheels	-	○	○
Metallic paint	-	○	○
SAFETY			
ABS with EBD (Electronic Brake Distribution)	●	●	●
ESP (not available on robotized gearbox)	-	○	○
Front driver's airbag	●	●	●
Front passenger's airbag	-	○	○
Cruise control / speed limiter	-	○	○
Reverse radar system with proximity sensors	-	○	○
Tyre repair kit	●	-	-
Normal size spare wheel (underbody)	-	●	●
Central Deadlocking	-	●	●
Manual key	●	-	-
2 button key	-	●	-
3 button key with selective opening	-	○	●
Renault Anti Intruder Device (Alarm)	-	○	○
VISIBILITY & DRIVING			
Power steering	●	●	●
Double optic front headlamps	●	●	●
Fog lamps	-	○	●
Rear windscreen wipers + Heated rear windows (not available with full steel bulkhead)	-	○	○
Manual rear-view mirrors	●	-	-
Electric rear-view mirrors	-	●	●
Digital tachograph (not on crew cab)	-	○	○
Trip computer	-	○	●
90 litre fuel tank	●	●	●
COMFORT			
Front manual heating	●	●	●
Front manual air conditioning	-	○	●
Pollen filter	-	○	●
Automatic headlamps and front windscreen wipers (light and rain sensitive sensors)	-	○	○
INTERIOR, DASHBOARD & SEATS			
Storage: cup/can holders, refrigerated glove box, storage tray	●	●	●
Overhead storage rack in cab (only with High Roof)	●	●	●
Smoker pack	-	●	●
Driver's seat with armrest	-	●	●
Front passenger's single seat	●	○	○
2 seat front passenger fixed bench seat	-	●	●
GALATONE upholstery	●	-	-
ELBA GREY upholstery (Blue on Crew Cab)	-	●	●
Vinyl upholstery	-	○	○
Floor anchorage points in the load area (not on Crew Cab)	-	●	●
Side anchorage points in the load area (not on Crew Cab)	-	○	●
BULKHEADS			
Full steel bulkhead (glazed on Crew Cab)	-	●	●
Full (glazed) bulkhead	-	○	○
1/3 bulkhead with mesh (not on Crew Cab)	●	○	○

PANEL VAN & CREW CAB

	Business *	Comfort	Executive **
DOORS AND WINDOWS			
Rear steel doors with 180° opening	●	●	○
Rear glazed doors with 180° opening	-	○	○
Rear steel doors with 270° opening (only with LWB Low Roof variants)	-	○	●
Rear glazed doors with 270° opening (only with LWB Low Roof variants)	-	○	○
Glazed tailgate + Rear windscreen wipers + Heated rear windows (only with Low Roof variants)	-	○	○
Left hand sliding door (unglazed) (glazed on Crew Cab)	-	●	●
Left hand sliding door with fixed window (standard on Crew Cab)	-	○	○
Left hand sliding door with opening window	-	○	○
Right hand sliding door (unglazed)	-	○	○
Right hand sliding door with fixed window (standard on Crew Cab)	-	○	○
Right hand sliding door with opening window	-	○	○
Manual front windows	●	-	-
Electric front windows	-	●	-
One touch electric front windows	-	○	●
COMMUNICATION			
2 stereo speakers	-	●	●
Steering wheel control	-	●	●
Radio MP3 CD with separate display & RCA Outlet + Bluetooth® + Plug & Music	-	●	●
Carminat TomTom® LIVE navigation system (Ireland map)	-	○	○
OTHER EQUIPMENT			
150A load capacity alternator + high capacity battery	-	○	○
Engine power take-off	-	○	○
B30 biodiesel compatibility	-	○	○

● : Standard; ○ : Optional; - : Not available

EQUIPMENT LEVELS ***

<p>Standard equipment*</p> <p>ABS with EBD (Electronic Brake Distribution) Manual heating Front driver's airbag 1/3 bulkhead with mesh Galatone upholstery</p>	<p>Tyre repair kit Manual front windows Front passenger's single seat Rear steel doors with 180° opening 90 litre fuel tank</p>	<p>Manual rear-view mirrors 16" steel wheels Manual key</p>	BUSINESS
<p>Additional standard equipment = Business +</p> <p>Left hand sliding door (unglazed) Small wheel caps Radio MP3 CD with separate display & RCA Outlet + Bluetooth® + Plug & Music Steering wheel control</p>	<p>Driver's seat with armrest Smoker pack 2 seat front passenger fixed bench seat Elba Grey upholstery Electric front windows</p>	<p>Electric rear-view mirrors Normal size spare wheel (under body) 2 button key Central Deadlocking</p>	COMFORT
<p>Additional standard equipment = Comfort +</p> <p>Front manual air conditioning Rear steel doors with 270° opening Trip computer</p>	<p>Large wheel trims One touch electric front windows Fog lamps</p>	<p>Side anchorage points in the load area (8) 3 button key with selective opening</p>	EXECUTIVE

* only available on SL - SWB LOW ROOF - 2.7t ** Not on Crew cab

*** Specifications can vary according to stocks

5
YEARS WARRANTY
UNLIMITED
MILEAGE

RENAULT Finance

RENAULT Finance the bank you can bank on.
Choose the finance solution that best suits your needs

At **RENAULT Finance**, we pride ourselves on being:

- **Flexible.** We have flexible payment plans. We can tailor the term, the deposit or the repayment to meet your needs.
- **Competitive.** We offer competitive rates and attractive financial packages you will not find anywhere else.
- **Simple.** We provide an easy application process, quick decision and minimum paperwork, all at your Local Dealer.
- **Creditable.** We are part of one of Europe's largest motor finance companies and offers financial services to millions of customers everyday.

Renault Finance is a trading name of RCI Banque Branch Ireland, a wholly owed subsidiary of the Renault Group.
RCI Banque is regulated by the French banking authority and is supervised by the Central Bank of Ireland for conduct of business purposes.



RENAULT TRAFIC



RENAULT LCV, NUMBER ONE IN EUROPE SINCE 1998

(www.renault.ie)



5
YEARS WARRANTY
UNLIMITED
MILEAGE

RENAULT recommends **elf**

The utmost has been done to ensure that the content of this publication is accurate and up-to-date when going to press. This document has been created on the basis of pilot lots and prototypes. As part of its ongoing product improvement policy, Renault reserves the right to modify the specifications, vehicles and accessories described and shown at any time. Such modifications are communicated to Renault dealers as quickly as possible. Depending on the country of sale, certain versions may differ and certain equipment may be unavailable (as standard, optional or accessory). Please contact your nearest dealer for the latest information. For printing reasons, the colours which appear in this document may differ slightly from the actual paint and the upholstery colours. All rights reserved. It is forbidden to reproduce in any format and by any means all or part of this publication without prior written authorisation from Renault.

