

The new Viano. FUN & MARCO POLO



Mercedes-Benz

Enjoy the greatest adventure of our time:
independence

Contents

The new Viano FUN & MARCO POLO	5	Equipment and appointments	50
Comfort	12	Standard equipment	52
Safety	16	Special equipment	56
Viano FUN	20	Colours and materials	58
COMFORT FUN equipment package	26	Paintwork	58
		Upholstery, leather and trim	60
Viano MARCO POLO	28	Combination options	61
Life on board	32		
Sleeping	34	Technical data	62
Cooking and stowage	38	Engine data and weights	62
WESTFALIA camper-van equipment	41	Dimensions	64
Agility	42	Glossary	68
Engines and transmissions	44	Services	70
BlueEFFICIENCY	46	Test drive	74
4MATIC	48		

The new Viano recreational vehicles and camper vans from Mercedes-Benz

Do you like turning your tail lights on everyday life? Are you spontaneous and full of get-up-and-go? Do you place importance on comfort and safety? If you answered yes to all three questions you'll be delighted to hear that there are two new companions for you: the Viano FUN, a multitalented vehicle for family and free time, and the Viano MARCO POLO, a compact camper van not averse to adventure on a bigger scale – both of them also perfectly suited to everyday use. Help yourself to as much freedom as you like!





When they wake up in the morning, some people have no idea what the evening will have in store

The new Viano FUN recreational vehicle

Life is full of possibilities, and it's a fantastic feeling when you can try them all out: with the new Viano FUN, the excitingly versatile recreational vehicle from Mercedes-Benz. With room for up to seven people, a highly variable seating system and any amount of space for luggage, it can be adapted to suit your requirements at the drop of a hat – whether your next destination is the DIY store or the beach. And if it starts getting a bit late – no problem at all. A bench seat that can be folded down to create a bed turns the Viano FUN into your own personal hotel on wheels.

On a Monday, others have no idea where they'll be star-gazing on Friday

The new Viano MARCO POLO camper van

A trip to the countryside today, off to the coast for a week tomorrow: whatever you feel like doing, the new Viano MARCO POLO will take you to the destination of your dreams in comfort. With sleeping accommodation for up to four people, a well-thought-out concept that makes the best possible use of the space available and a high degree of functionality, this easy-to-manoeuvre camper van impresses even on longer journeys. The particularly homely ambience and the high-quality fittings from our experienced partner WESTFALIA help to ensure that you feel at home wherever you happen to be. Enjoy the intensive experience of freedom and adventure – there's a whole world out there waiting to be discovered.





But there is one thing of which they are all certain: it has to be a Mercedes-Benz

The new Viano recreational vehicles and camper vans from Mercedes-Benz form a base you can always rely on, even when you're far away from home. With its exemplary variability, handling and safety equipment, the Viano shows just how comfortable travelling can be these days. For even more ride comfort, the newly developed comfort suspension is now available: it boasts new spring/damper tuning plus new wishbones and comfort bearings. The result can be heard and felt all over: improved road roar and tyre vibration characteristics and noise levels that have been cut even further. Amid all the emotions aroused by its striking design and high-quality appointments and equipment, there is, of course, still plenty of room for being sensible – in the form of especially economical engines, the standard-fit BlueEFFICIENCY package¹ and the proverbial Mercedes-Benz reliability and durability.

¹ Not available in conjunction with petrol engine





Just get in to get away from it all

Take one look at the interior of the Viano FUN and Viano MARCO POLO and it's clear that you'll be travelling in comfort: thanks to numerous detailed measures, both the ambience and operating comfort have been considerably improved. You'll be settling down on even higher-quality seat covers and you'll be delighted with the new control elements, which have been manufactured with great care. The clearly structured ergonomic cockpit with its "Silverstone" decor has a particularly high-grade feel, thanks to the soft-touch surface¹. The centre console offers plenty of stowage space with its cup holders and large compartments.



All the displays and switches have been arranged in such a way that they are easy for the driver to read and operate. This also applies to the handy joystick-style shift/selector lever which is situated in the centre console where it can be reached with ease, also facilitating free access through to the side or rear. On long journeys especially you'll appreciate the comfort seats with an armrest and swivel function² – they are ergonomically shaped, have a particularly wide adjustment range and very good lateral structure.

¹ On the Viano FUN only available with the COMFORT package

² Swivel function on the Viano FUN only available in the compact version

Standard on the Viano MARCO POLO (pictured right), optional on the Viano FUN (pictured left): the new 4-spoke multifunction steering wheel, whose control buttons can be used for calling up and operating lots of different functions





Leisure time designed for pleasure

In the Viano MARCO POLO and the compact version of the Viano FUN, the front seats can be turned to face the rear. With their ergonomic shape and excellent lateral support they offer a high level of seating comfort



The redesigned, easy-to-access shift/selecter lever is one of the many details that enhance the interior of the new Viano FUN and MARCO POLO even further



The TEMPATIC air conditioning system with a combined dust and activated charcoal filter (standard for the MARCO POLO and for the FUN in conjunction with the COMFORT FUN package) ensures a pleasant climate whatever the weather. You can increase climate comfort further still with an optional separately adjustable rear air conditioning system





- RADIO DISC
- NAVI TEL
- 4x SYS
- FM TEL

P
R
N
D+



S VI 1084



Even if you don't yet know what your destination is: we want you to reach it safely

So that you'll never have to rely on your lucky stars alone whilst enjoying your various recreational and travel activities, we've developed a well-rounded integral safety concept for the Viano. Its basis is formed by a safety body with a high-strength passenger cell and numerous very efficient safety components. For an impressive degree of active safety the Viano has all the important electronic driver assistance systems included on board.

It goes without saying that the WESTFALIA fittings of the Viano MARCO POLO also meet all the Mercedes-Benz safety standards: they are crash-tested and manufactured from flame-retardant materials.



We won't leave you high and dry if the worst comes to the worst

The standard-fit adaptive brake light sees to it that the traffic behind is better warned during emergency braking – by flashing the brake lights in a critical braking situation. If vehicle is braked to a standstill, the hazard warning lamps are automatically switched on



The optional automatic tyre pressure monitoring system can help to prevent tyre failure which might have serious consequences: it warns the driver where there is a significant loss of tyre pressure



The new bi-xenon headlamps (special equipment) with their integral cornering light function, front fog lamps and LED daytime driving lights not only illuminate the road surface and the surrounding area better – when the indicators are activated the front fog lamps are switched on – on the side in question – (cornering light function), just as they are from a certain steering angle when cornering (Add-Light System)



Goodbye everyday routine.
Hello life.
The new Viano FUN





Because every day brings new things to discover ...

The new Viano FUN

The Viano FUN's sheer variability and whole host of possible applications give you plenty of room for manoeuvre – whether you're going about your daily routine or heading for the hills in your free time. If you opt for the compact version of the FUN, you'll find that there is plenty of room for five people. The two front occupants make themselves at home on comfort seats which can be swivelled round to face the rear when the vehicle is stationary. There they will see a folding table fitted to the side and a bench seat for three passengers. The bench seat is both movable and



removable and it can be folded for use as a high-comfort bed. The passenger compartment now sports sidewall trim in anthracite throughout, plus new grab handles with an integral reading light and ambient lighting which provides pleasant light conditions during the journey.

The long version of the Viano FUN offers enough space to carry up to seven people in comfort. The centre row of seating is equipped with a comfortable individual seat (or, optionally, with two individual seats). The floor rail system allows the individual seats to be moved in 25-mm steps and to be installed facing the direction of travel or with their backs to it. And what is more they can be removed quickly and easily. Right at the back there is a three-seater bench seat providing the same functionality as on the compact version. The standard equipment also includes a folding table; this, too, can be adjusted and secured using the floor rail system.





... as does the night, sometimes

The new Viano FUN

You can be spontaneous to your heart's content with the Viano FUN, as it turns into a mobile hotel in the twinkling of an eye whenever you want it to: just fold down the bench seat and together with the bed extension you have a generous area on which to lie. A pop-up roof is available as an option for the long Viano FUN, giving you a pleasant amount of headroom - and with the electrohydraulic EASY UP version this even happens at the touch of a button. If you wish, a roof bed can also be added to the pop-up roof, creating sleeping room for up to four people.



Viano FUN, compact version
(seating configuration)



(Bed configuration)

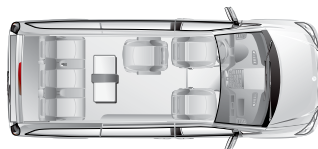

Viano FUN, long version
(seating configuration)



(Bed configuration)









The COMFORT FUN equipment package

COMFORT FUN is available exclusively for the Viano FUN. It enhances the interior, making it even cosier.

COMFORT FUN package

Additional heat exchanger in rear, adjustable via a new roof control unit

Ambient lighting

Armrests with ornamental strips

Carpet in driver's section

Carpet panels in foot area of sidewall trim

Electric vent windows in second rear seat row

Fabric inserts in sidewall trim

Illuminated vanity mirrors in both sun visors

Luxury cockpit with a soft-touch surface, decor strip and shift lever knob in "Silverstone"

Multifunction steering wheel

Two additional rear interior lights integrated into the grab handles

Freedom can't feel any better than this.
The new Viano MARCO POLO





WESTFALIA

S VI 1087

At home all over the world

The new Viano MARCO POLO

Whilst it might not be evident at first glance due to the compact dimensions, the new Viano MARCO POLO offers its enterprising passengers ample space, lots of intelligent solutions and an interior that is now even more inviting through the use of new materials and colours. And thanks to the two swivelling front seats and the movable bench seat, a cosy area in which to sit and relax or eat can be set up around the variable folding table in the sliding door. Incidentally, the table can even be used during the journey. With the standard-fit floor rail system, the bench seat



can be moved in 25-mm steps, allowing various different configurations for the luggage compartment. The vehicle offers plenty in the way of stowage space – you'll be pleased to learn that this includes particularly spacious cupboards for supplies, a large roof stowage box and lots of room in the wardrobe.

And just in case your next trip should take you to the car park of a furniture store for a change – absolutely no problem, because you can turn your camper vehicle into a practical van: by taking out the bench seat the MARCO POLO's luggage compartment can be increased to cover an area of up to 3.38 m² with no trouble at all.

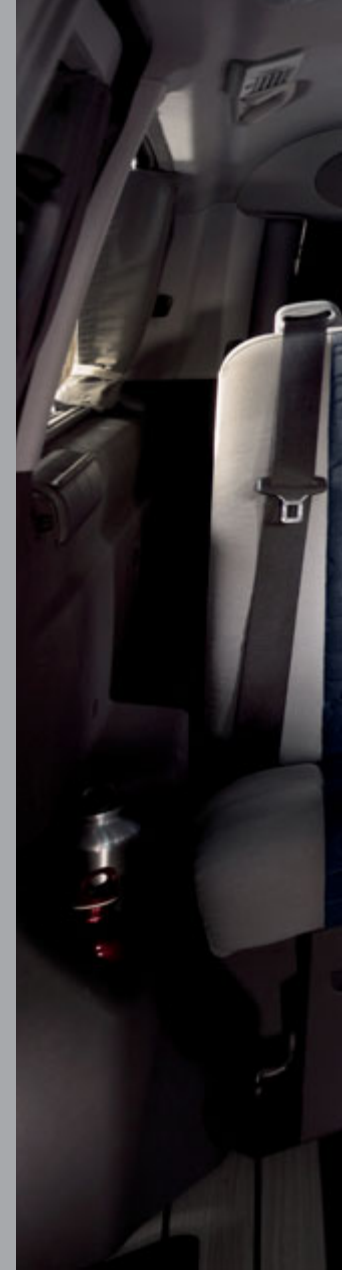



Perfectly planned, impeccably implemented

The new Viano MARCO POLO

The bench seat can be moved in 25-mm steps, allowing you to vary the size of the luggage compartment to meet your requirements. And if you slide the bench seat as far forward as it will go, any children on board remain within easy reach (a bonus, as any parent will know)



The bench seat converts easily into a bed and back again thanks to the electrically adjustable backrest. Pneumatic seat cushion bolsters ensure optimum comfort: the well-contoured seats turn into a flat bed area in a matter of seconds



The Viano MARCO POLO offers stowage space galore, such as the practical, spacious drawer under the bench seat

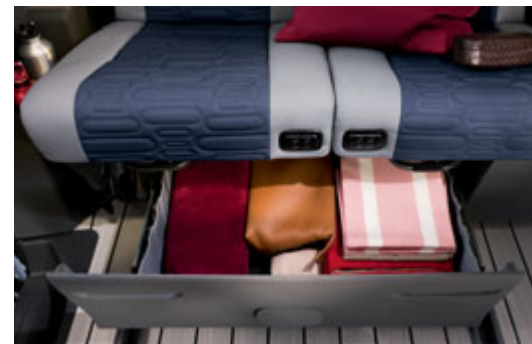



Rooms with a view

Sleep well - in the new Viano MARCO POLO

On board the Viano MARCO POLO you'll find everything you need for a good night's sleep: on the "ground floor" a double bed can be set up in next to no time from the movable bench seat and bed extension, and thanks to pneumatic seat cushion bolsters it offers a high degree of comfort. Measuring around 2.03 x 1.18 m, the bed invites you to make yourself at home with everything that was stored in the spacious

bed box beneath the bench seat during the day. The Viano MARCO POLO's standard-fit pop-up roof boasts ample headroom (up to 2.40 m). Whilst it can easily be brought into the upper position manually, the touch of a button takes care of this as an option: with the EASY UP electro-hydraulic pop-up roof, an innovation from Mercedes-Benz.

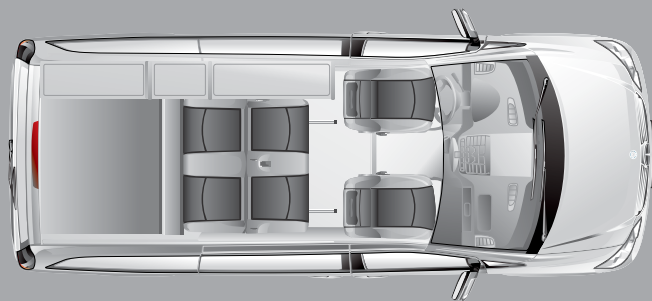

Bed on the "ground floor"

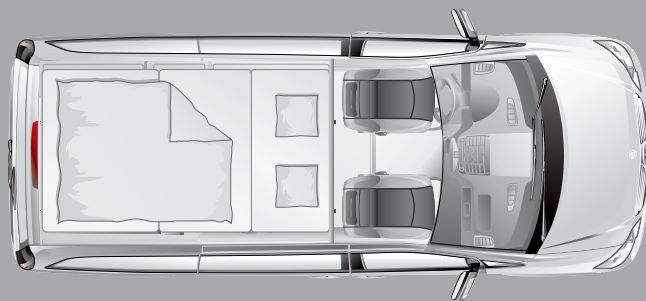

Roof bed

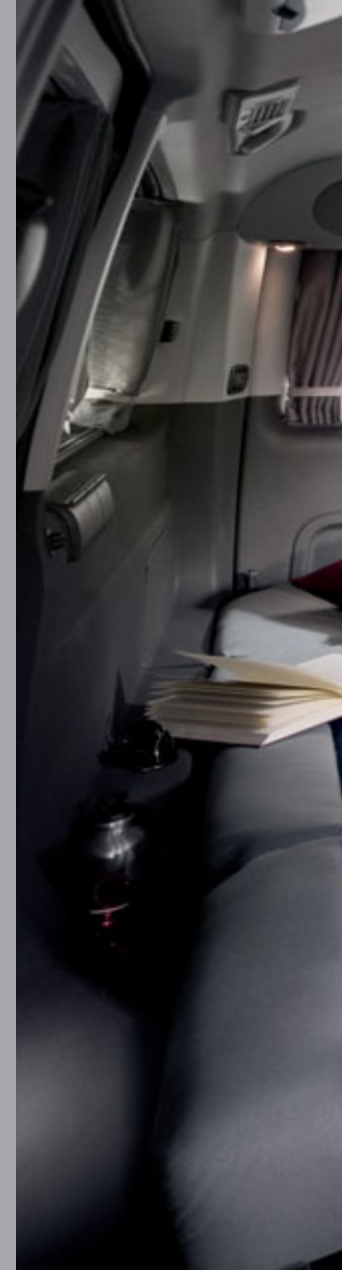





Sweet dreams are made of this

The standard-specification roof bed in the new Viano MARCO POLO

The practical stowage flap in the rear offers additional stowage space for cushions and blankets



Thanks to the standard-fit protective net, the roof bed is also ideal as a “cave” in which children can sleep. And they love playing up there, too



The roof bed consists of a comfortable foam mattress resting on special flexible spring elements. This high-quality system fits especially snugly to the body and ensures very good air circulation as well as feeling very pleasant to lie on



Home cooking tastes best

The kitchen unit in the new Viano MARCO POLO

From a light snack to your favourite cooked meal, after a long day out and about you can reward yourself with whichever culinary delights take your fancy in your Viano MARCO POLO. Everything you need is housed in the practical kitchen unit: a dual-burner gas stove, a sink with a single-lever mixer tap, a spacious 40-litre*** compressor-type coolbox (down to -20 °C) and, of course, loads of stowage space in the kitchen cupboards with practical roller fronts. Additional clever

details, such as the fold-down stove cover which doubles as a worktop or the smoothly adjustable folding table, make this well-designed compact kitchen as practical as it is attractive.

And you can always rely on the Viano MARCO POLO's well-proven supply technology. The stove is powered by a space-saving gas bottle, and both the generously dimensioned (36-litre) fresh-water tank and the 32-litre waste-water tank¹ are housed in the interior of the vehicle, where they are protected against frost.



¹ The water supply is state of the art as of 10/2007 (Directive 2002/72/EC)



Plenty of room for delicious ideas

The kitchen unit in the new Viano MARCO POLO





Cool and calm: the 40-litre*** compressor-type coolbox is extremely quiet and operates with either 12 V/220 V or gas



Several kitchen cupboards and a compressor-type coolbox offer lots of space for food and drinks



The gas bottle (Camping Gaz, 2.8 kg) is stored in the vehicle's tail end to save space. A clever touch: for better access the rear section of the cupboard situated above the gas bottle has been designed to rotate

WESTFALIA camper-van equipment

36-l fresh-water tank ¹ , 32-l waste-water tank	●
Auxiliary 80 Ah lead-gel battery with cut-off relay	●
Awning, pull-out design, over sliding door	○
Central display and control panel for outside and inside temperature, battery strength and charge status, coolbox status, water-tank levels, heater control	●
Dual-burner gas stove (Camping Gaz)	●
EASY UP electrohydraulic pop-up roof	○
Electrolux 40-l compressor-type coolbox, (down to -20 °C)	●
Exterior 220 V CEE socket, battery charger	●
One 220 V socket, one 12 V socket	●
Pop-up roof, manual	●
Roof bed for pop-up roof (approx. 2.00 x 1.15 m) incl. protective net and sprung support system	●
Sink with single-lever mixer tap	●
Table, removable	●
Twin bench seat/high-comfort bed with bed extension (approx. bed area 2.03 x 1.17 m)	●

● Standard equipment ○ Special equipment

¹ The water supply is state of the art as of 10/2007 (Directive 2002/72/EC)



Seize that sense of freedom – and just keep on driving



We're fuelled by efficiency

The new Viano's engines

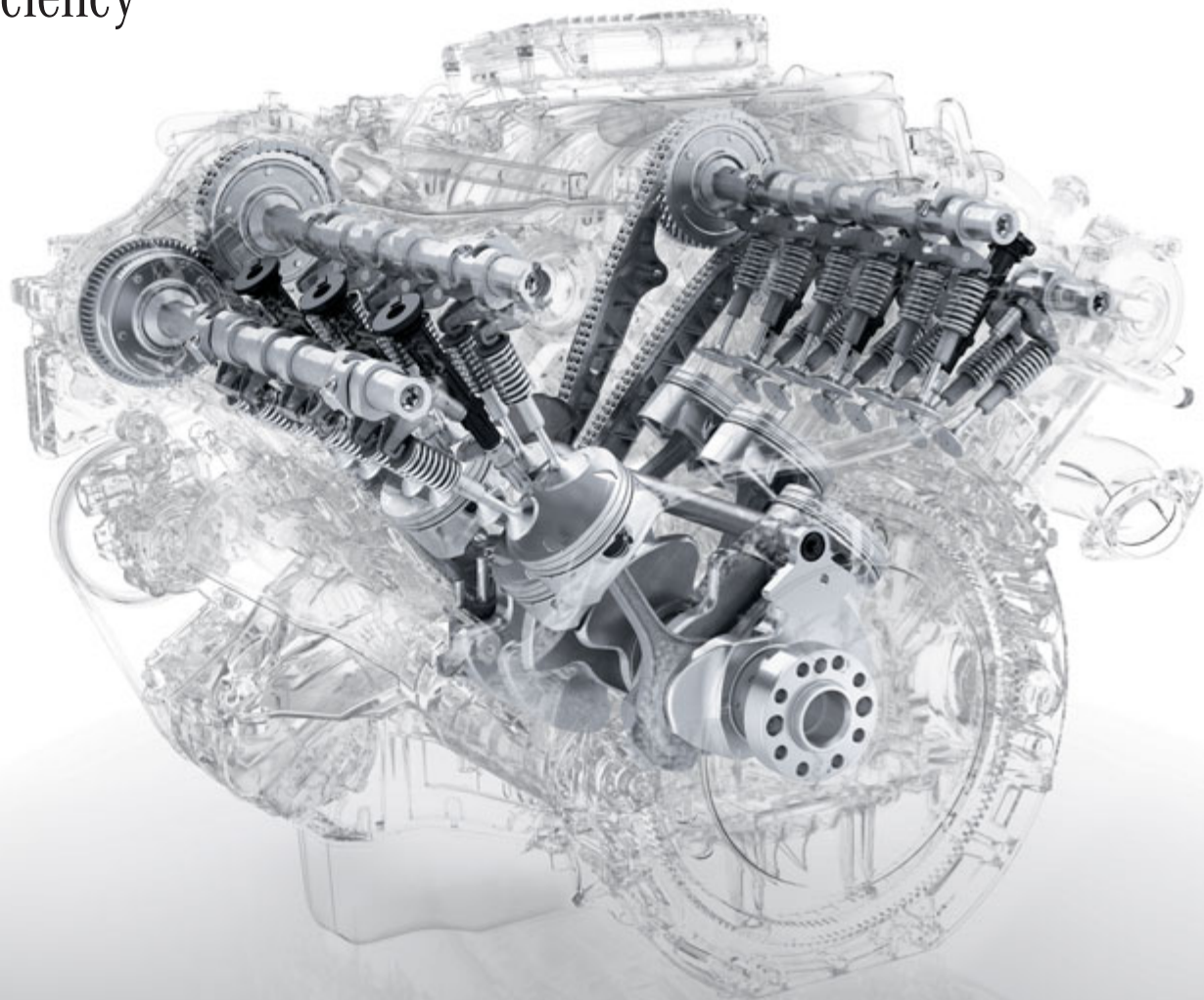

There are three frugal CDI diesel engines for you to choose from for your Viano, all of them entering new dimensions where output and performance are concerned. The newly developed OM 651 4-cylinder CDI diesel engine, available in two power categories, ensures yet more dynamism. The top engine of the trio, the OM 642 V6 CDI diesel engine, has also been updated; with 165 kW and a maximum torque of 440 Nm it masters tough tasks with hallmark reliability. All three CDI diesel engines comply with the EU 5/III exhaust emissions regulation and are characterised by considerably reduced fuel consumption, fewer exhaust emissions and enhanced refinement compared with the previous engines. As an alternative to the CDI diesel engines, a V6 petrol engine with a displacement of 3.5 l and 190 kW is available, and it now complies with the EU 5/I emissions standard.

The V6 CDI diesel engine is combined with the tried-and-tested 5-speed automatic transmission, as is the V6 petrol engine (available as an option with 4-cylinder CDI diesel engines)



The newly developed ECO Gear 6-speed manual transmission is the ideal partner for the 4-cylinder CDI diesel engines. It makes an additional contribution towards optimising consumption thanks to a greater gear ratio spread and a reduction in the engine speed level

A close-up, low-angle shot of the side of a white car. The car's body panels are highly reflective, showing bright highlights and soft shadows. A blue badge with white text is mounted on the side panel. The text on the badge is 'BLUE EFFICIENCY'. The car's window and a portion of the rearview mirror are visible in the upper right. The background is a clear blue sky with a bright light source creating a lens flare effect.

BLUE EFFICIENCY

BlueEFFICIENCY

Innovations for efficient mobility

Mercedes-Benz recognises that it has an obligation to live up to the standard it has set for itself: to shape the future of mobility in a responsible and sustainable manner. The route to achieving this goal goes by the name of BlueEFFICIENCY: a package of intelligently combined, innovative technologies that contribute towards a tangible reduction in fuel consumption and pollutant emissions. You can now experience the positive effects for yourself in the Viano with a 4-cylinder diesel engine or a V6 CDI diesel engine – without having to relinquish safety, comfort or driving pleasure. The standard-specification BlueEFFICIENCY package¹ includes the following measures:

- ▶ Economical 4-cylinder CDI diesel engine in 2 new power categories
- ▶ An advanced V6 CDI diesel engine (with automatic transmission)
- ▶ Consumption-optimised ECO Gear² 6-speed manual transmission
- ▶ Further fuel economy measures included in specification depending on model variant (e.g. ECO start/stop function², shift-point display², ECO power-steering pump, in-engine measures, battery management, closed-loop fuel pump and tyres with optimised rolling resistance)

¹ Not available in conjunction with petrol engine

² Omitted in conjunction with automatic transmission

Outstandingly capable through thick and thin.
And wet and slippery.
And smooth and steep

The Viano with 4MATIC¹ permanent all-wheel-drive



In case you and your Viano should often come up against inclement weather and road conditions, we can recommend the optionally available 4MATIC¹ permanent all-wheel drive. It transfers engine power to all four wheels simultaneously, transmitting it to the front and rear axle in a ratio of 35 : 65. The result is noticeably improved traction, even on snow and wet leaves, poor roads, on slippery surfaces and with a trailer in tow. The 4MATIC is ably supported by the Electronic

Stability Program ESP[®] and the electronic traction system 4ETS. It intervenes whenever one or several wheels start to spin. In so doing it brakes the spinning wheels individually, increasing the drive torque at the wheels which still have sufficient adhesion. This boosts power when moving off and accelerating, particularly on a poor road surface. And because 4ETS in the Viano is integrated into the standard-specification ESP[®], the 4MATIC is even more effective.

¹ Available for the Viano CDI 2.0 and CDI 2.2. All-wheel drive is not available in all countries

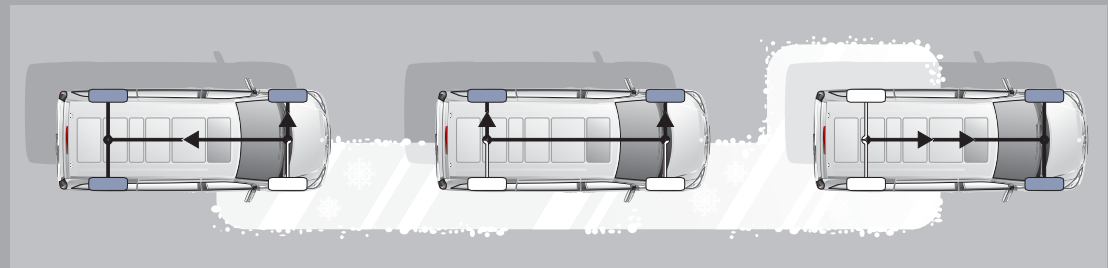

4ETS. The 4MATIC models work with the electronic traction system 4ETS instead of mechanical differential locks. It automatically directs the drive torque to the wheels with the best road adhesion







Standard equipment

2 LED reading lights in the rear

5-speed automatic transmission for V6 CDI engine and petrol engine

6-speed manual transmission for 2.0 and 2.2 CDI engines

Adaptive brake lights

Additional heat exchanger in the rear

Airbags for driver and front passenger with emergency fuel shut-off

ASSYST service computer

Bed extension (can be raised in MARCO POLO)

BlueEFFICIENCY package for CDI engines 2.0, 2.2 and 3.0

Comfort seats for driver and front passenger, manually adjustable

Compartment for valuables beneath the front passenger seat¹ (lockable)

Diesel particulate filter

Disc brakes all round

Driver and front passenger sun visors, illuminated mirrors

Electronic brake force distribution (EBD)

Electronic Stability Program (ESP®) including anti-lock braking system (ABS), acceleration skid control (ASR), Brake Assist (BAS)

ESP® trailer stabilisation in conj. with trailer coupling or pre-installation for a trailer coupling (both special equipment)

Extended central locking system with radio remote control

Grab handle with reading light and ambient lighting²

Heated exterior mirrors, electrically adjustable and automatically folding, with aspherically curved mirror glass and integral indicator lamps

Multifunction steering wheel¹

Outside temperature display

Power steering with safety steering column

Power windows for driver and front passenger, with one-touch control and obstruction sensor

Reflective headlamps with enlarged reflector, front fog lamps and daytime driving lights with separate light source

Seat rail system

Steering column adjustable for height and angle

Tailgate with wash/wipe system

TEMPMATIC air conditioning system

Three-point seat belts for all seats; with belt tensioners and belt-force limiters for driver and front passenger

Tinted glass all round

Vehicle-coloured bumpers, rub strips and door handles

¹ Special equipment for Viano FUN

² Not available for the Viano MARCO POLO



ECO Gear 6-sp. man. transmission for 2.0 & 2.2 CDI engines

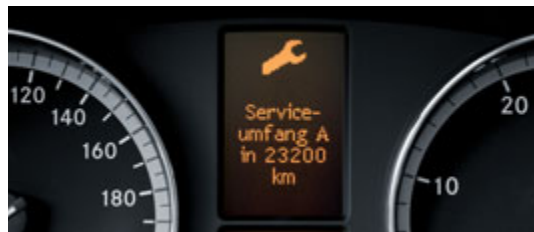

ASSYST service computer

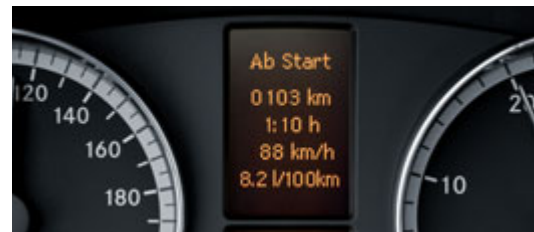

High-resolution matrix display



Steering wheel adjustable for height and angle



The seat rail system for variable configuration of the interior



Power windows, power vent windows and electrically adjustable exterior mirrors



TEMPATIC electronically controlled air conditioning system



Additional heat exchanger for the rear with separate control unit



Exterior mirrors with greater field of vision and integral indicator lamp, electrically adjustable



Refl. headlamps: fr. fog lamps & daytime driving lights



Design highlight: the new tail lights



Airbag for driver and front passenger¹



Adaptive brake lights



2 gooseneck reading lights in the pop-up roof (standard for the MARCO POLO, optional for the FUN)

¹The illustration shows various activated airbags (maximum deployment) – for illustrative purposes only



The automatic tyre pressure monitoring system



Bi-x headlamps: corn. light funct./fr. fog lamps/LED dayt. dr. lights



Pull-out awning over the sliding door



EASY UP electrohydraulic pop-up roof

Floor covering with yacht-deck look¹ in passenger compartment

Sound 50 APS radio/navigation system

Electric tilting/sliding sunroof for the rear⁵A clean business: the rear shower¹

Special equipment

4MATIC all-wheel drive²

Additional sliding door on left^{3,7}

Anti-theft alarm system (ATA)

AUX interface in glove compartment, e.g. for MP3 player

COMFORT FUN³ equipment package (see page 27 for details)

Comfort telephony package with exterior aerial and mobile-phone-specific holder (accessory)

Coolbox 16 l³

Cruise control with SPEEDTRONIC variable speed limiter

Driver's and front passenger seats electrically adjustable (for longitudinal position, height and inclination of seat and height of head restraint) with 3 memory settings

Electric tilting/sliding sunroof in driver's section

Exterior mirrors electrically folding

Headlamp cleaning system

Heated front seats

Hot-air auxiliary heating with 7-day timer⁸ also with radio remote control as an option

Hot-water auxiliary heating with 1-day timer also with radio remote control as an option

Insect screen for sliding windows⁶

Light and rain sensor

Light-alloy wheels 7 J x 17 or 7.5 J x 18

LINGUATRONIC: voice-operated control system for telephone

PARKTRONIC (parking aid)

Privacy curtains all round⁶

Radio and communication systems with navigation, CD changer and sound system

Rear air suspension with electronic self-levelling function

Roof bed for pop-up roof⁴ incl. protective net and sprung support system

Roof rails⁵

Single seat, 1st rear seat row, right¹

Sliding windows, left and right, at 1st seat row

Start-off Assist system (for manual models)

TEMPMATIC air conditioning system for rear

THERMOTRONIC automatic climate control system

Tinted rear windows (black)

Trailer coupling

Twin bench seat, 1st rear seat row¹

Windowbags for driver and front passenger

¹ Only available for MARCO POLO

² Available for Viano CDI 2.0 and CDI 2.2, only in conjunction with automatic transmission

³ Available for FUN only

⁴ Special equipment for long version of FUN, standard for MARCO POLO

⁵ Not in conjunction with pop-up roof

⁶ Standard for MARCO POLO

⁷ Not available for compact version of FUN

⁸ Not in conjunction with petrol engine

Paintwork

NON-METALLIC PAINTS



arctic white 9147



pebble grey 7701



flame red 3534



aqua green 6830



atlantis blue 5373



velvet red 3583

The Viano's paint provides a brilliant finish for the sophisticated corrosion prevention system from Mercedes-Benz. The bodywork is fully galvanised and treated with a cavity-fill preserving agent ex factory, which ensures durable protection against corrosion.

METALLIC PAINTS



obsidian black ME¹ 9197



brilliant silver ME¹ 9744



sanidine beige ME¹ 1798



amber red ME¹ 3548



jasper blue ME¹ 5345



cubane silver ME¹ 9723



flint grey ME¹ 7368

¹ Metallic paintwork is available as an option

The seats of your Viano are characterised by their robust and particularly comfortable design. You can add the perfect finishing touches by selecting your favourite fabrics or leather covers.

FABRIC

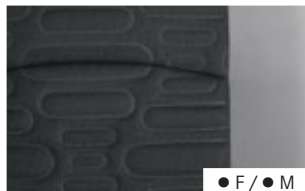

● F / ● M

Callao, anthracite

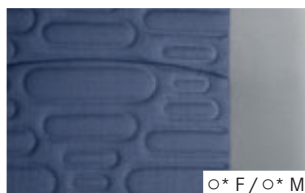

○* F / ○* M

Callao, blue

LEATHER



○ F / ○ M

Lugano, orion grey

TRIM

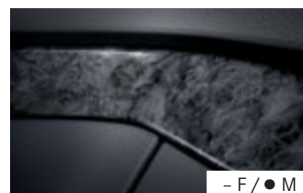

○ F / - M

Silverstone¹

- F / ● M

black burr-walnut-look

- Standard equipment
- Available as an option
- * Available as an option at no extra charge
- Not available
- F Viano FUN
- M Viano MARCO POLO

¹ Available for Viano FUN in conjunction with optional COMFORT FUN equipment package (standard with single-tone soft-feel decor)

	FABRIC		LEATHER	
	Callao, anthracite	Callao, blue	Lugano, orion grey	
NON-METALLIC PAINTS				
arctic white 9147	■	■	■	
aqua green 6830	■	-	■	
atlantis blue 5373	■	■	■	
velvet red 3583	■	-	■	
pebble grey 7701	■	■	■	
flame red 3534	■	-	■	
METALLIC PAINTS				
obsidian black ME 9197	■	■	■	
brilliant silver ME 9744	■	■	■	
cubanite silver ME 9723	■	■	■	
jasper blue ME 5345	■	■	■	
amber red ME 3548	■	-	■	
flint grey ME 7368	■	■	■	
sanidine beige ME 1798	■	■	■	

■ Recommended □ Possible - Not recommended

Engine, consumption and emissions data

Model	with rear-wheel drive				with 4MATIC all-wheel drive	
	CDI 2.0	CDI 2.2	CDI 3.0	3.5	CDI 2.0 4MATIC	CDI 2.2 4MATIC
No. of cylinders	4	4	6	6	4	4
Fuel	Diesel			Premium unleaded	Diesel	
Total displacement [cc]	2143	2143	2987	3498	2143	2143
Rated output [kW (hp)] at engine speed [rpm]	100 (136) 3800	120 (163) 3800	165 (224) 3800	190 (258) 5900	100 (136) 3800	120 (163) 3800
Max. torque [Nm] at engine speed [rpm]	310 1400–2600	360 1600–2400	440 1400–2800	340 2500–5000	310 1400–2600	360 1600–2400
Acceleration ¹ 0–100 km/h [s] (in conj. w. man./aut. transmission)	14.1/13.5	12.1/11.1	–/9.1	–/10.4	–/16.0	–/13.0
Top speed approx. [km/h] (in conj. w. man./aut. transmission)	174/172	188/182	–/201 ²	–/217 ²	–/161	–/174
Tank capacity [l]	75	75	75	75	75	75

¹ Performance figures for a weight in accordance with DIN 70020-3 (corresponding to the EC kerb weight + payload of 200 kg)

² Top speed with pop-up roof limited to 190 km/h

³ Figures according to Directive 92/21/EC, version applicable at the time of going to press, (kerb weight incl. tools/spare wheel, if supplied by manufacturer, fuel tank 90% full, driver 68 kg and luggage 7 kg; fresh-water tank and gas bottles 90% full) for standard-specification vehicles. Special equipment and accessories will generally increase this figure and reduce the payload capacity accordingly.

Note: according to ISO-M06 1176, the kerb weight figures are reduced by up to 75 kg

⁴ In conjunction with optional load uprating

⁵ Only in conjunction with automatic transmission

⁶ With pop-up roof max. 50 kg

⁷ With manual transmission

⁸ With automatic transmission

⁹ The figures shown were obtained in accordance with the prescribed measuring process [Directive (EC) 715/2007 in the currently applicable version]. The figures are not based on an individual vehicle and do not constitute part of the product offer; they are provided solely for purposes of comparison between different vehicle models

Model	with rear-wheel drive				with 4MATIC all-wheel drive	
	CDI 2.0	CDI 2.2	CDI 3.0	3.5	CDI 2.0 4MATIC	CDI 2.2 4MATIC
Kerb weight ³ [kg] (compact/long/extra-long)						
FUN	2025/2050/-	2025/2050/-	2100/2150/-	2020/2070/-	2105/2130/-	2105/2130/-
MARCO POLO	-/2260/-	-/2260/-	-/2320/-	-/2240/-	-/2340/-	2340
Perm. GVW [kg]	2800/3050			2800/3050	2800/3050	
Payload capacity [kg]	775-1025	775-1025	700-950	780-1030	695-945	
Towing capacity [kg]						
Unbraked	750	750	750	750	750	750
Braked	2000	2000	2000	2000	2000	2000
Increased in conj. w. special equipment (braked)	2500 ⁵	2500	2500	2500	2500 ⁴	2500
Tyre size	205/65 R 16	205/65 R 16	225/60 R 16	225/60 R 17	205/65 R 16	205/65 R 16
Max. roof load [kg] ⁶	150	150	150	150	150	150
Track circle/turning circle Ø [m]	11.0/11.8	11.0/11.8	11.0/11.8	11.0/11.8	11.8/12.7	11.8/12.7
Transmission	M6 ⁷ /A5 ⁸	M6 ⁷ /A5 ⁸	A5 ⁸	A5 ⁸	A5 ⁸	A5 ⁸
CO ₂ emissions ⁹ , combined [g/km] (in conj. w. man./aut. transmission)	190-195/211-216	190-195/211-216	-/224-226	-/279-284	-/232-234	-/232-234
Fuel consumption ⁹ [l/100 km] (in conj. w. man./aut. transmission)						
Urban	8.8-9.0/10.0-10.2	8.8-9.0/10.0-10.2	-/10.8-10.9	-/16.3-16.5	-/11.1-11.2	-/11.1-11.2
extra-urban	6.4-6.6/6.8-7.0	6.4-6.6/6.8-7.0	-/7.1-7.2	-/9.3-9.5	-/7.4-7.5	-/7.4-7.5
combined	7.2-.4/8.0-8.2	7.2-7.4/8.0-8.2	-/8.5-8.6	-/11.9-12.1	-/8.8-8.9	-/8.8-8.9

Viano FUN dimensions

Compact version

Side view

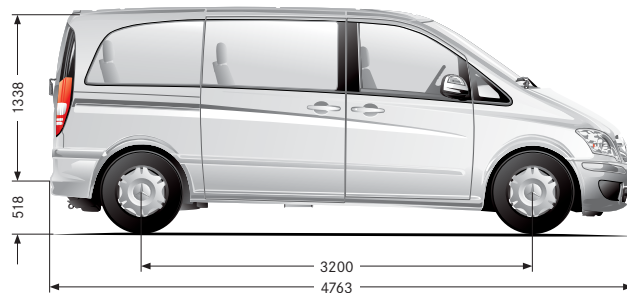

Seat position with folding table

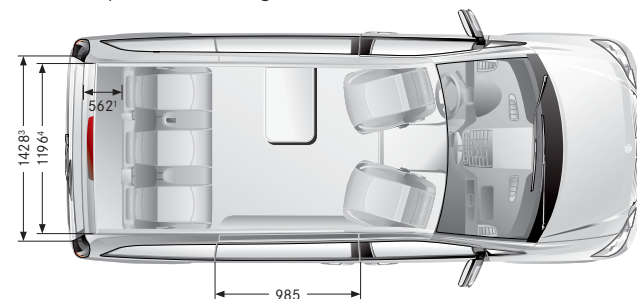

Long version

Side view

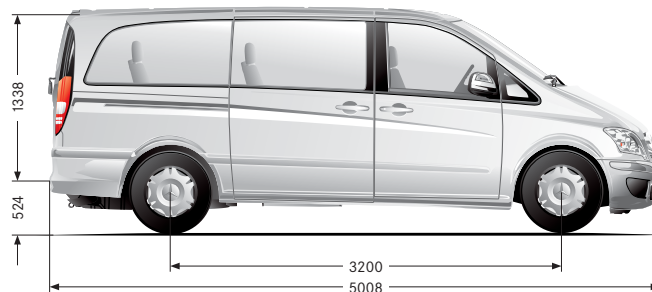

Seat position with butterfly table

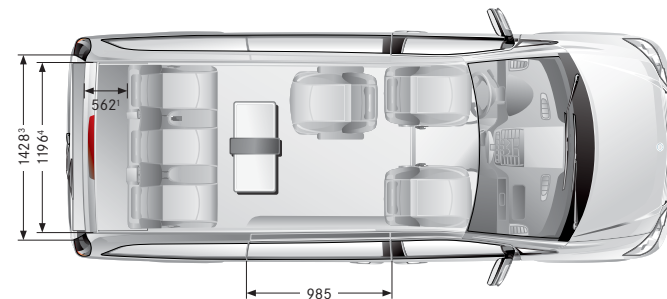

All illustrations similar. Dimensions stated are average figures (all measurements in mm).
They apply to unladen vehicles with the standard specification

Bench in berth position

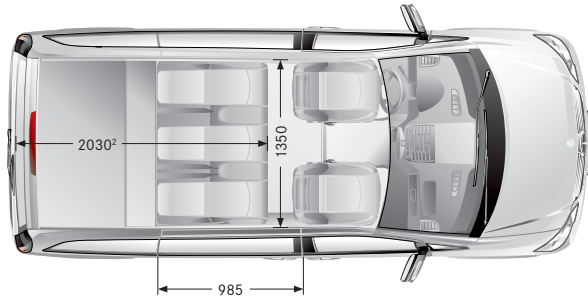

Without seating in rear

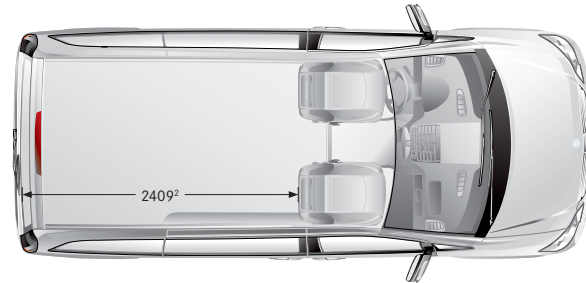

Front

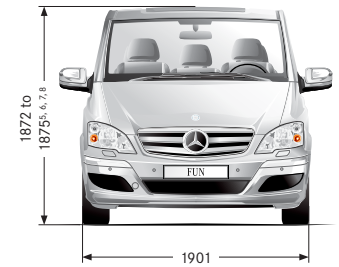

Bench in berth position

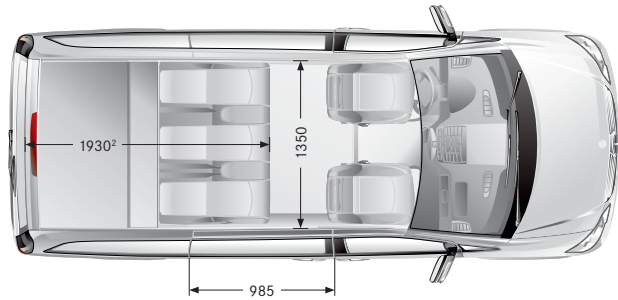

Without seating in rear

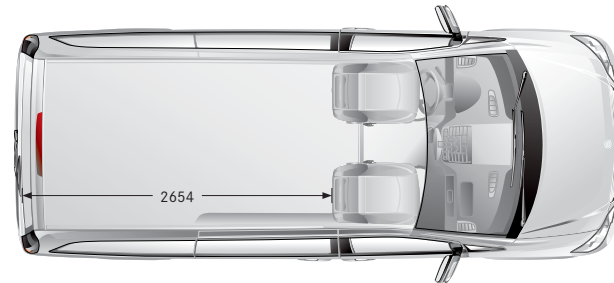

Tail end



(2013 with exterior mirrors folded in)

¹ Dimensions can be increased by moving/removing seats

² Dimension measured on vehicle floor

³ Internal dimensions excluding wheel arches

⁴ Internal dimensions between wheel arches

⁵ Vehicle height varies depending on vehicle length

⁶ Optional roof rails increase vehicle height by 48 mm

⁷ Optional pop-up roof only with long version of Viano FUN with a vehicle length of 1960 mm

⁸ Vehicle height in conj. with optional 4MATIC all-wheel-drive version: between 1939 and 1942 mm

Viano MARCO POLO dimensions

Viano MARCO POLO

Pop-up roof with roof bed: standard for MARCO POLO, available as an option for FUN¹.

At just under 2 metres in height in its standard guise, the MARCO POLO keeps a low enough profile to go just about anywhere – including most multi-storey car parks.

With the roof raised, the maximum interior height is 2.40 metres.

Side view with raised pop-up roof

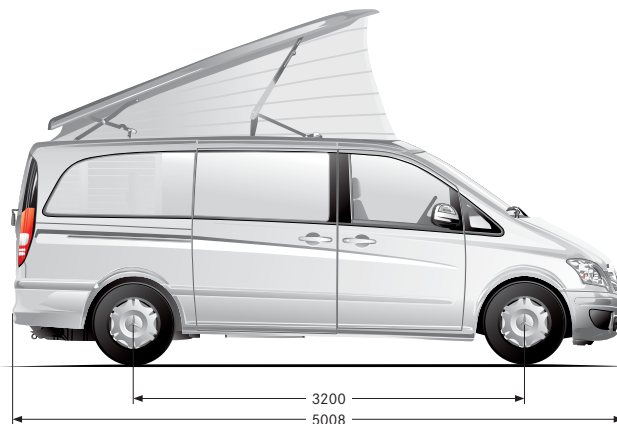

Side view



Roof bed in the pop-up roof

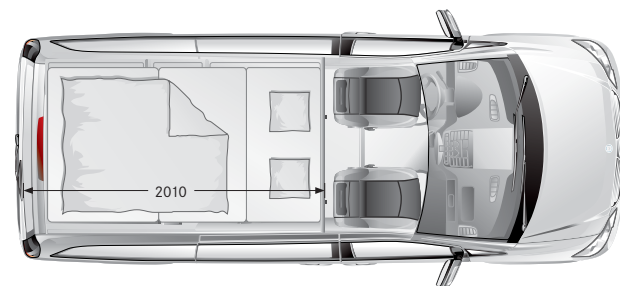

Bench in seat position

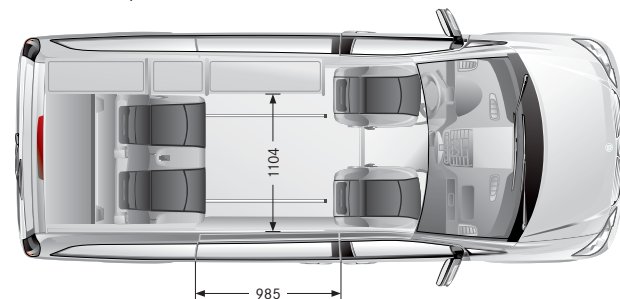

¹ Only available with long wheelbase for FUN

Without seating in rear

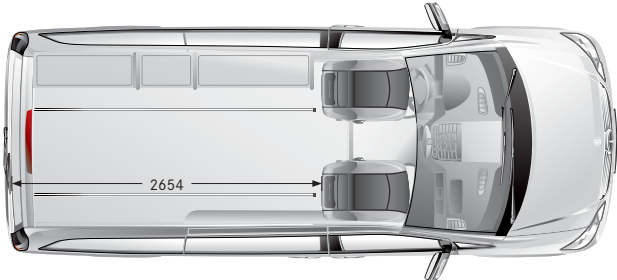

Bench in berth position

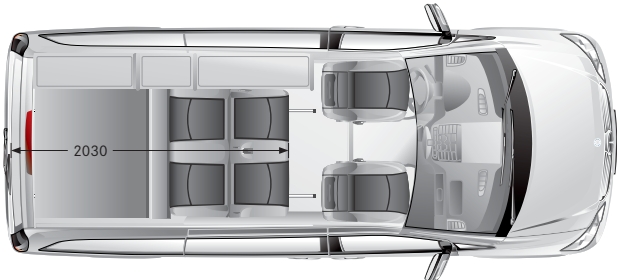

Front



Front with pop-up roof raised

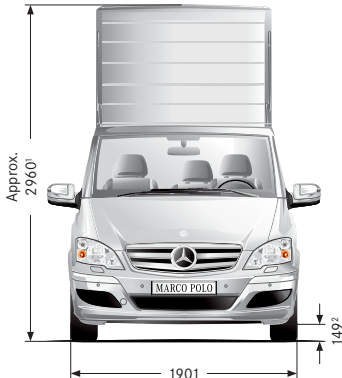

Tail end



(2013 with exterior mirrors folded in)

Figures for 4MATIC all-wheel-drive version:
 ¹ Vehicle height with pop-up roof raised 3030 mm
 ² Ground clearance 154 mm
 ³ Vehicle height approx. 2025 mm

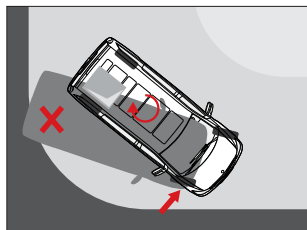

Electronic Stability Program ADAPTIVE ESP®

ADAPTIVE ESP® is an innovative dynamic handling control system which for the first time also takes the vehicle load into account. It actively intervenes in certain hazardous driving situations, e.g. if there is an imminent risk of skidding, through brake actuation at one or more wheels and adjusting the engine output as required so as to help the driver deal with the hazardous situation. As well as aiding directional stability, ADAPTIVE ESP® combines the functions of the anti-lock braking system (ABS), accel-

eration skid control (ASR), electronic brake force distribution (EBD), Brake Assist (BAS) and the optional Start-off Assist system (AAS). The ESP® trailer stabilisation provides enhanced handling safety when towing a trailer.

Note:

ADAPTIVE ESP® can only act within the limits imposed by the laws of physics. As a result, it cannot prevent skidding caused by aquaplaning, for example. If the driver exceeds these limits, even ADAPTIVE ESP® will not be able to prevent an accident!

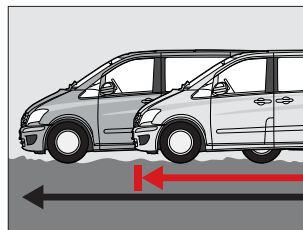

Brake Assist (BAS)

In tests carried out in the driving simulator, our research engineers established that drivers do not apply the brakes vigorously enough during emergency braking. This finding led them to develop Brake Assist. From the speed at which the brake pedal is depressed, Brake Assist is able to detect a situation where emergency braking is required. In such a situation the system automatically increases braking power, aided by the anti-lock braking system (ABS) which prevents the wheels from locking up.

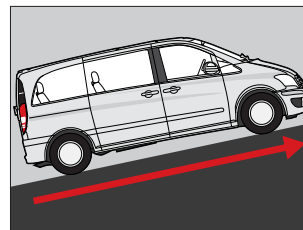

Start-off Assist system (AAS)

The Start-off Assist system (standard with the automatic transmission), an integral part of ESP®, makes it easier to start off on uphill slopes: after the brake pedal is released, the brake pressure is maintained for approximately two seconds, allowing the driver to move their foot from the brake pedal to the accelerator without having to worry about the vehicle starting to roll. The Start-off Assist system is activated on uphill slopes of approx. 4% or steeper. It is not activated when starting off on the flat or on a downhill slope.

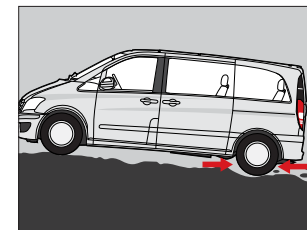

Acceleration skid control ASR

At the first signs of wheel spin, that is to say if the rotational speed of one of the driven wheels suddenly increases, ASR reduces the engine power and also intervenes in the brake system to prevent prolonged wheel spin. ASR ensures smooth start-off and acceleration, without prolonged wheel spin or sideways drift. The result is improved traction – and safety – particularly on split-friction or slippery surfaces.

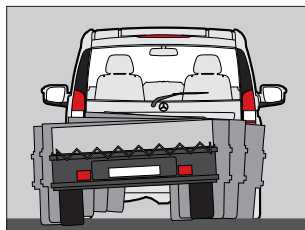

ESP® trailer stabilisation

This system complements ADAPTIVE ESP® and improves handling safety when towing a trailer by precisely braking the wheels of the towing vehicle and reducing the engine torque if the trailer fishtails, therefore helping the driver to stabilise the vehicle/trailer combination. In the event of several activations in succession, the applied braking power is increased continually, resulting in a substantial reduction in the vehicle speed.

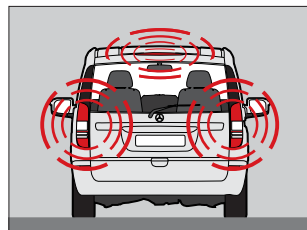

Adaptive brake lights

The adaptive brake lights enhance active safety as they give a clearer signal when the vehicle is braked in an emergency. This is achieved thanks to the fact that all the brake lights start to flash in the event of emergency braking at speeds above 50 km/h, thus warning the traffic behind and shortening the reaction times of the drivers behind. If the vehicle is braked to a standstill from a speed of above 70 km/h, the hazard warning lights are activated automatically.

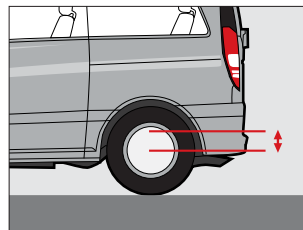

Air suspension with level control system

The rear air suspension has electronic level control to ensure safe roadholding whatever the vehicle load, a comfortable ride for passengers and safe transport of shock-sensitive cargo. The electronic level control keeps the vehicle at the same level regardless of the vehicle load, which has benefits in the dark as the road ahead is always well illuminated without dazzling other drivers. The vehicle can be raised and lowered manually at the push of a button, making loading and unloading much easier.

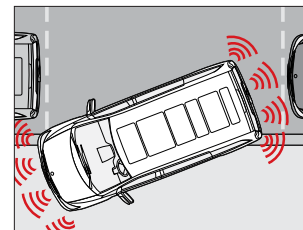

PARKTRONIC

PARKTRONIC is a parking aid which assists the driver when parking or manoeuvring in confined spaces. Working on the same principle as an echosounder, the system automatically warns the driver of obstacles in front of or behind the vehicle. The warning is provided initially in the form of a visual display in the centre of the instrument panel. When the distance to an obstacle falls below 35 cm, the audible warning is also activated, first intermittently and then as a continuous tone at a distance of about 20 cm.

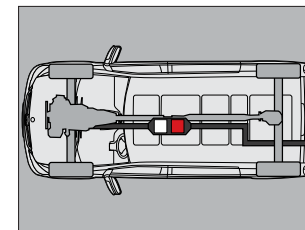

Diesel particulate filter

Particulate emissions per diesel car have been drastically lowered in recent years. Nonetheless, the constantly increasing number of diesel vehicles means that high levels of total emissions must be reduced further. The diesel particulate filter from Mercedes-Benz is a breath of fresh air in this respect. It removes more than 95% of the particulates from the exhaust gases. At the same time a continuous regeneration process prevents the filter from becoming clogged – which means that no fuel additives are needed.

Anyone opting for a Mercedes buys much more than a vehicle

To ensure your sustainable mobility we think beyond the vehicle itself. From a repair service and mobility packages right up to individual financing and leasing schemes, we offer a wide range of services designed to keep you and your Viano on the road.

Experience Mercedes-Benz service and that special excitement surrounding the brand in our sales and service outlets the world over or at your local dealership. They all offer you an extensive range of services, comprehensive care and the quality you rightly expect from Mercedes-Benz.





Service and parts

Extended opening hours

Mercedes-Benz Service24h

Mercedes-Benz ExpressService

Mercedes-Benz MobilityGo

Mercedes-Benz genuine parts

Mercedes-Benz genuine remanufactured parts

Financing and leasing

Standard financing

Final-instalment financing

Option financing

Leasing

Finance leasing

Final-instalment leasing

Insurance

Vehicle insurance

GAP insurance

Payment protection

Extension of warranty

The comprehensive service from Mercedes-Benz

Extended opening hours. Many Mercedes-Benz service outlets are open from Monday to Friday until 8 p.m., 10 p.m. or, in some cases, around the clock, enabling you to have extensive maintenance and repair work carried out when your vehicle is not in use.

Mercedes-Benz Service24h. We are always there for you: if your Mercedes should ever have starting problems or break down en route, our free¹ Service24h hotline (on 00800 3 777 7777) will arrange expert assistance for you as soon as possible. This hotline is available from all over Europe. 365 days a year, 24 hours a day, our service teams ensure that you are back on your way again without delay.

Mercedes-Benz ExpressService. Vehicle availability is everything – that’s why we offer you the Mercedes-Benz ExpressService. Oil changes and the smaller maintenance tasks along with the replacement of wear parts and minor repairs can be performed at a fixed price. There’s no need to make an appointment, and most of these tasks can be completed within 2 hours.

Mercedes-Benz MobilityGo. Mercedes-Benz MobilityGo gives you free on-the-spot breakdown or starting assistance should your vehicle break down or fail to start; the free MobilityGo service package also includes payment of taxi fares and the provision of a replacement vehicle. We will also keep you mobile and pay your costs if your vehicle has to go into the workshop under

warranty and the repairs are likely to take more than two hours. Your Mercedes-Benz dealer would be happy to provide you with further details about MobilityGo conditions and coverage – just drop in!

Mercedes-Benz genuine parts. Mercedes-Benz genuine parts undergo rigorous material and functional testing, are engineered to fit your vehicle perfectly and remain available for 15 years after the end of series production.

Mercedes-Benz genuine remanufactured parts. If your vehicle has been on the road for some time, Mercedes-Benz genuine remanufactured parts are an ideal choice. Reconditioned in accordance with the current state of the art, they

are subjected to the same function checks as new parts and come with the same high quality as our Mercedes-Benz genuine parts. There's one key difference: they cost up to 50% less!

MercedesCard. It acts as your ticket to the world of Mercedes-Benz and doubles as a practical credit card – with no annual fee if you complete our yearly questionnaire. The MercedesCard Journal regularly features details of exclusive sporting, travel and cultural events, as well as news of exciting products. The Mercedes Magazine contains fascinating articles covering every aspect of the Mercedes-Benz brand. And your MercedesCard gives you free entry when you visit the Mercedes-Benz Museum. Please consult your national Mercedes-Benz website for further details.

Mercedes-Benz Financial Services. If you already have your sights set on your Viano and want to remain flexible in financial terms, we can accommodate your wishes with our financial services. With standard financing, for instance, you buy your chosen model in convenient monthly instalments which always remain the same, giving you financial flexibility and getting you mobile with immediate effect. Or perhaps you would like a Viano with the colour, equipment and appointments of your choice but only want to pay for using it? In this case leasing is just right for you. With leasing instalments you don't tie up any capital, you retain your credit leeway and you always have an overview of your finances thanks to the fact that the instalments remain constant. From leasing to financing packages, insurance or service modules – we offer all these as one-stop

solutions with attractive conditions. Further information on the financing and leasing services offered by Mercedes-Benz Financial Services is available from www.mercedes-benz.com or your national hotline.

¹ This hotline number can be called toll-free from landline phones and mobile phones. In some European countries, calls from mobile phones are subject to a charge set by the network operator. If your network operator does not permit international/free calls, we recommend that you use the relevant supplementary number for the country concerned as an alternative. This can be found on the Service24h sticker in your vehicle



Time to get another experience under your seat belt

Test-drive the vehicle of your dreams

A Mercedes is most at home on the road. This is the only way to discover the effortlessly superior driving feel that makes every model so special. Discover the extent to which the Viano's variability and high level of comfort can enrich your everyday life. The special feeling you experience when out on the road simply cannot be put into words, so we would like to invite you to take a test drive. Your Mercedes-Benz dealer will be happy to make all the necessary arrangements for you. Simply visit www.mercedes-benz.com to locate your nearest Mercedes-Benz dealer. We look forward to seeing you.

The illustration on the left shows a Viano TREND



Take-back of end-of-life vehicles. Coming full circle. At the end of its long life, you can return your Viano to us for environment-friendly disposal in accordance with the EU End-Of-Life Vehicle Directive. But that day lies a long way off. The take-back of end-of-life vehicles applies in accordance with national regulations for vehicles up to 3.5 tonnes gross weight. The Viano has met the requirements governing the suitability of the vehicle's design for reuse and recycling for a number of years now. A network of vehicle take-back depots and dismantlers has been established which will process your vehicle in an environmentally friendly manner. The ways in which both vehicles and parts can be recovered are subject to ongoing development and improvement. Consequently, the Viano will be able to comply with any future increases in the recycling quota within the stipulated time limits. Further information is available from www.mercedes-benz.com or your national hotline.

Please note: changes may have been made to the product since this brochure went to press (31.01.2010). The manufacturer reserves the right to make changes to the design, form, colour or specification during the delivery period, provided these changes, while taking into account the interests of the vendor, can be deemed reasonable with respect to the purchaser. Where the vendor or the manufacturer uses symbols or numbers to describe an order or the subject of an order, no rights may be derived solely from these. The illustrations and descriptions may include accessories and items of special equipment which are not part of standard specification. Colours may differ slightly from those shown in the brochure, owing to the limitations of the printing process. This brochure may contain models and services which are not available in certain countries.

This brochure is distributed internationally. Information given regarding statutory regulations, legal requirements and taxation and the consequences thereof applies to the Federal Republic of Germany only and is correct at the time of going press. Please consult your Mercedes-Benz van dealer for final details.

www.mercedes-benz.com