

# RANGE ROVER VOGUE



GO BEYOND



THERE IS NOTHING ON EARTH TO COMPARE WITH RANGE ROVER VOGUE. Range Rover luxury has no limits. It's a vehicle that displays accomplished capability and sophistication, featuring a V8 Supercharged or Twin Turbo V8 Diesel engine, all-air suspension, all six-speed automatic transmission with CommandShift™. It demonstrates supreme off-road ability and sublime on-road handling.







FROM THE LEGENDARY RANGE ROVER COMMAND DRIVING POSITION the driver is perfectly placed to interact with the vehicle and the surrounding environment. This brings a sense of control and reduces stress and fatigue. At the heart of Range Rover Vogue's fascia is the high resolution touch-screen, an intuitive interface between driver and key functions of the vehicle. Getting in and out can be made even easier with accessory power side steps which complement the air suspension access mode.

FIRST-CLASS ENTERTAINMENT. Range Rover Vogue houses a superb **harman/kardon**® sound system. It has a six-disc changer compatible with CD and MP3 discs and featuring Digital Signal Processing (DSP) as standard. The premium system delivers 710 Watts of power to 14 speakers and brings LOGIC7® world-class audiophile quality to all passengers. A rear seat entertainment option has a six-disc DVD changer, headrest-mounted 6.5 inch twin screens and wireless headphones. In keeping with its ability to roam almost anywhere on the planet, Range Rover Vogue offers an easy-to-use DVD-based satellite navigation system which can be operated, on the move, manually or by voice control. Off-road navigation shows the contours of the terrain and provides the ability to mark way points in the memory.

**harman/kardon**® and LOGIC7® are registered trademarks of Harman International Industries Incorporated.





**UNMATCHED CAPABILITY OFF-ROAD.** The electronically controllable differential or E-DIFF works not only to deliver superior on-road traction, but also improve off-road traction by reducing cross axle wheel slip. The E-DIFF can act sooner and with more subtlety than traditional traction control systems because it does not rely on the intervention of the brakes. Standard on Range Rover Vogue Supercharged, and available as an option on TDV8, the electronic rear differential maximises every last bit of grip in adverse conditions. A centre E-DIFF, which splits the torque between front and rear wheels, is standard on every Range Rover.

**RANGE ROVER VOGUE'S LEGENDARY OFF-ROAD PERFORMANCE** is further enhanced by Terrain Response™. Using a fingertip control on the centre console any one of five settings can be chosen for different driving conditions. Automatically adjusting settings for engine, gearbox, brake control systems, air suspension, traction control and electronic centre and rear differentials, some of the most difficult conditions can be overcome. It succeeds in making the most demanding appear effortless.





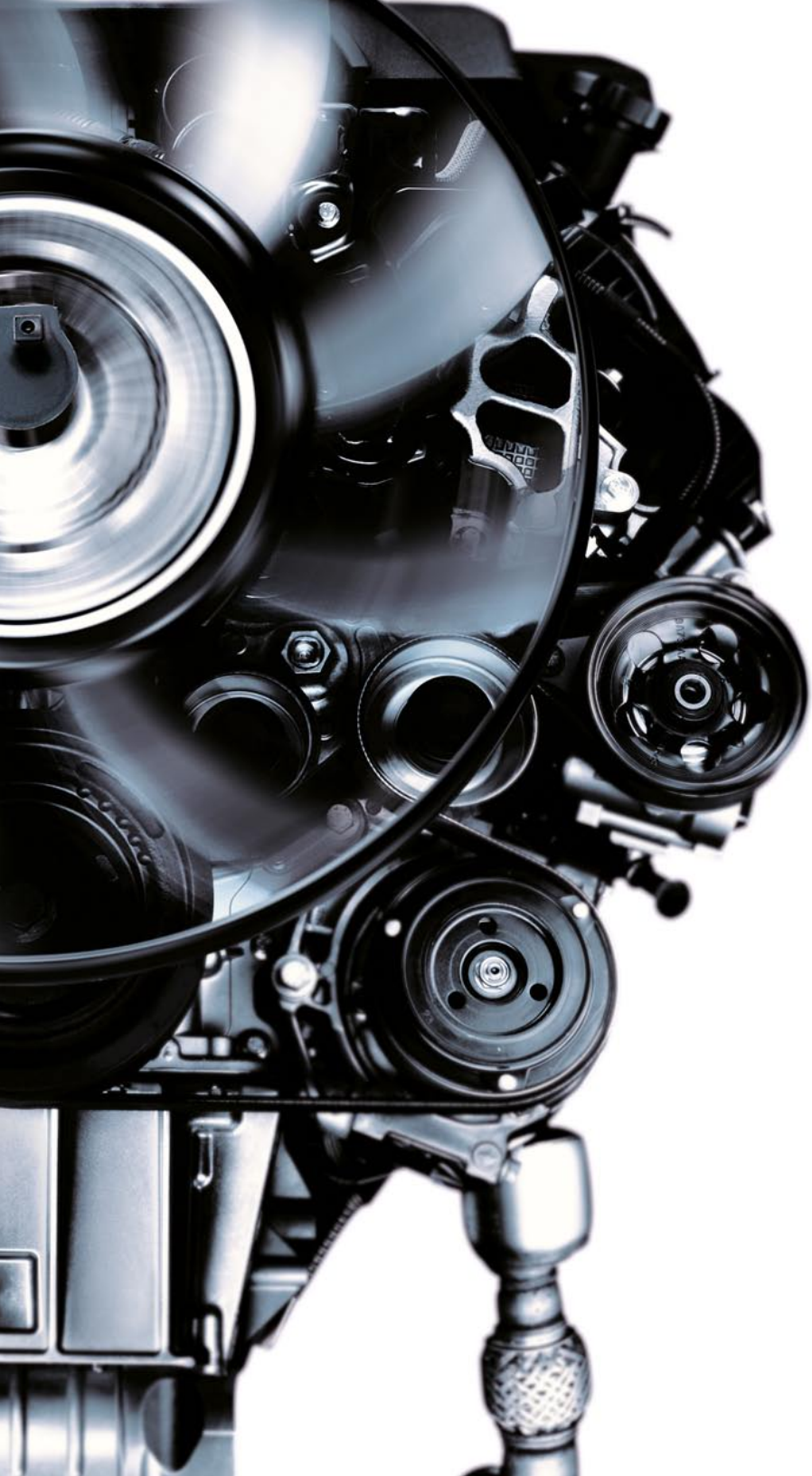

THE MOST POTENT, MOST REFINED DIESEL-POWERED RANGE ROVER. EVER. The ultra-civilised TDV8 diesel is now recognised as a state-of-the-art vehicle for efficiency, refinement and performance. Providing all the benefits of a petrol engine alongside the economy of a diesel. The TDV8 has established itself as a powerful alternative in the V8 line-up.

## ENGINE

Type	<b>Twin Turbo V8 Diesel</b>
Max Power	200kW @ 4,000rpm
Max Torque	640Nm @ 2,000rpm
Engine Data	90 degree 32 Valve Diesel engine. Compacted graphite iron cylinder block to reduce noise levels with an aluminium head to improve heat dissipation. Fuel injection pressure of 1,700 Bar with a state-of-the-art twin variable nozzle turbochargers and inlet valve deactivation deliver supreme refinement, power and fuel economy. The advanced technology in the TDV8 allows it to exceed EU4 emissions levels by up to 20 percent. Bore 81mm (3.19in). Stroke 88mm (3.464in). Cubic capacity 3,630cc. Compression ratio 17.3:1.

TDV8



THE RANGE ROVER VOGUE SUPERCHARGED. The supreme expression of Land Rover's most complete luxury 4x4. A supercharged V8 lightweight engine makes this the most powerful Range Rover ever made. It offers 291kW and an astonishing 560Nm of torque to deliver immediate, supple acceleration. Standard on Range Rover Vogue Supercharged are a Noble finish front grille and side power vents, dramatically enhanced with diamond mesh to maximise airflow. Special 20 inch alloy wheels, chrome tail pipes and distinctive black and silver Land Rover badging affirm the high performance credentials of the Range Rover Vogue Supercharged at a glance. There is also stainless steel detailing on brake and accelerator pedals.

## ENGINE

Type	<b>Supercharged V8 Petrol</b>
Max Power	291kW @ 5,750rpm
Max Torque	560Nm @ 3,500rpm
Engine Data	Supercharged V8 Petrol. Aluminium construction of engine block and cylinder head with a structural sump and oil pick-up designed to enable operation at extreme angles. 32 Valve with quad camshafts and Supercharged with peak pressure of 80kPa (0.8 Bar). Torque based engine management system, mapped for both on and off-road driving speeds. Drive by Wire throttle control and multi-holed fuel injectors. Three way catalysts, unleaded fuel only. Bore 86mm (3.386in). Stroke 90.3mm (3.55in). Cubic capacity 4,197cc. Compression ratio 9.1:1.



**SAFETY IS INHERENT IN THE DESIGN, CONSTRUCTION AND SYSTEMS OF RANGE ROVER VOGUE.**

The strength of Range Rover Vogue's body and chassis, required to support its legendary off-road and towing abilities, also provides for a very strong passenger cell that helps protect its occupants in an accident. This inherent strength is complemented with nine airbags (including a driver's knee airbag), special bolsters in the new front door trims and lower glovebox lid as well as high strength steel beams in each of the doors. Active safety technology plays a major role. For example, the 4x4 systems developed to enable Range Rover Vogue to creep down slippery hills also assist in maintaining control on icy roads, seeking out all available grip and helping to keep the car going in the intended direction. Vehicle systems also predict when a roll-over is likely and apply force on the appropriate wheel to counter the roll.



All Range Rover Vogues have leather interiors which are available in Blenheim or full Oxford depending on the model chosen.



**FULL OXFORD LEATHER**  
Ventilated heated/cooled front seats Range Rover Vogue TDV8 Luxury and Supercharged



**BLENHEIM LEATHER**  
Standard heated front seats and driver memory Range Rover Vogue TDV8



**10 WAY ADJUSTMENT SEAT**  
Range Rover Vogue TDV8 Luxury and Supercharged





19 INCH, 7-SPOKE ALLOYS  
'STYLE 4' - 255/55 R19



20 INCH, 9-SPOKE ALLOYS  
'STYLE 6' - 255/50 R20



20 INCH, 7-SPOKE ALLOYS  
'STYLE 5' - 255/50 R20





EXTERIOR COLOUR CHOICES

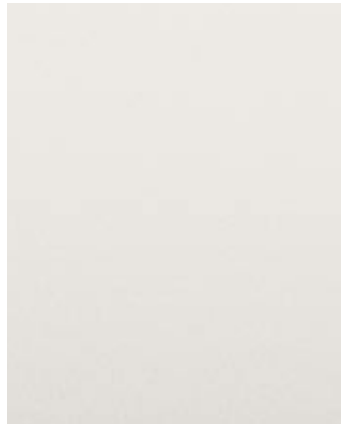

ALASKA WHITE (SOLID)

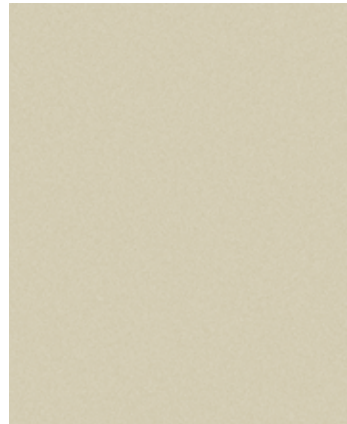

ATACAMA SAND (METALLIC)



BUCKINGHAM BLUE (METALLIC)



CAIRNS BLUE (METALLIC)

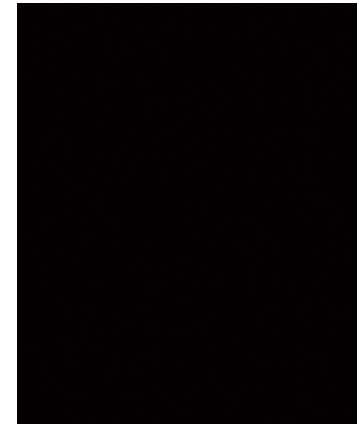

JAVA BLACK (METALLIC)



LUCERNE GREEN (METALLIC)



RIMINI RED (METALLIC)



STORNOWAY GREY (METALLIC)



TONGA GREEN (METALLIC)



ZERMATT SILVER (METALLIC)

INTERIOR COLOUR CHOICES



ASPEN

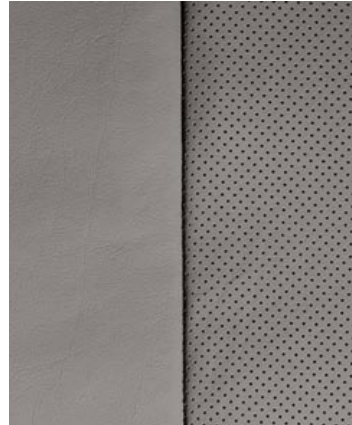

STORM



IVORY

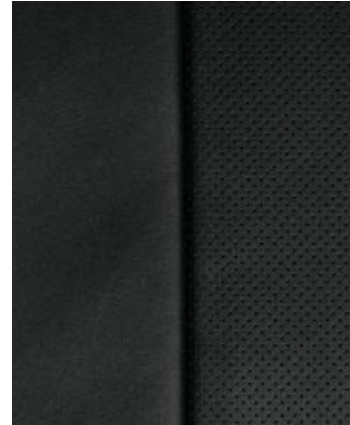

JET



NAVY



PARCHMENT



SAND





INTERIOR FINISH



BURR WALNUT

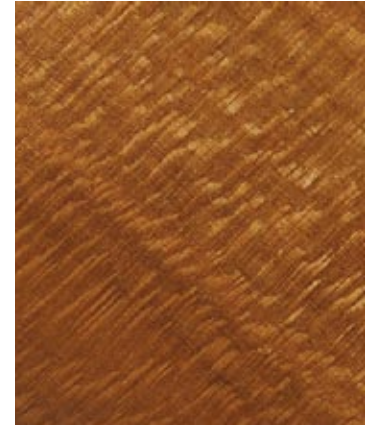

CHERRY WOOD













GRAND BLACK LACQUER







GRANITE

COLOUR AND TRIM MATRIX

COLOURWAYS (IP TOPPER/CENTRE)		JET/JET	JET/IVORY	JET/STORM	ASPEN/IVORY		NAVY/PARCHMENT		JET/SAND	
SEAT COLOUR		JET	IVORY	STORM	ASPEN	IVORY	NAVY	PARCHMENT	SAND	SAND
EXTERIOR COLOUR										
	Alaska White	<input type="checkbox"/>	<input type="checkbox"/>	<input type="checkbox"/>	<input type="checkbox"/>	<input type="checkbox"/>	<input type="checkbox"/>	<input type="checkbox"/>	<input type="checkbox"/>	<input type="checkbox"/>
	Atacama Sand	<input checked="" type="checkbox"/>	<input type="checkbox"/>	<input type="checkbox"/>	<input type="checkbox"/>	<input type="checkbox"/>	<input type="checkbox"/>	<input type="checkbox"/>	<input type="checkbox"/>	<input type="checkbox"/>
	Buckingham Blue	<input type="checkbox"/>	<input checked="" type="checkbox"/>	<input type="checkbox"/>	<input type="checkbox"/>	<input type="checkbox"/>	<input checked="" type="checkbox"/>	<input checked="" type="checkbox"/>	<input type="checkbox"/>	<input type="checkbox"/>
	Cairns Blue	<input type="checkbox"/>	<input type="checkbox"/>	<input type="checkbox"/>	-	<input type="checkbox"/>	<input type="checkbox"/>	<input checked="" type="checkbox"/>	<input type="checkbox"/>	<input type="checkbox"/>
	Java Black	<input checked="" type="checkbox"/>	<input checked="" type="checkbox"/>	<input checked="" type="checkbox"/>	<input type="checkbox"/>	<input type="checkbox"/>	<input type="checkbox"/>	<input type="checkbox"/>	<input checked="" type="checkbox"/>	<input checked="" type="checkbox"/>
	Lucerne Green	<input type="checkbox"/>	<input type="checkbox"/>	<input type="checkbox"/>	<input checked="" type="checkbox"/>	<input checked="" type="checkbox"/>	-	-	<input type="checkbox"/>	<input type="checkbox"/>
	Rimini Red	<input checked="" type="checkbox"/>	<input checked="" type="checkbox"/>	<input checked="" type="checkbox"/>	-	-	-	<input type="checkbox"/>	<input type="checkbox"/>	<input type="checkbox"/>
	Stornoway Grey	<input checked="" type="checkbox"/>	<input type="checkbox"/>	<input checked="" type="checkbox"/>	<input type="checkbox"/>	<input type="checkbox"/>	<input type="checkbox"/>	<input type="checkbox"/>	<input type="checkbox"/>	<input type="checkbox"/>
	Tonga Green	<input type="checkbox"/>	<input type="checkbox"/>	<input type="checkbox"/>	<input type="checkbox"/>	<input checked="" type="checkbox"/>	-	-	<input checked="" type="checkbox"/>	<input type="checkbox"/>
	Zermatt Silver	<input checked="" type="checkbox"/>	<input checked="" type="checkbox"/>	<input checked="" type="checkbox"/>	<input type="checkbox"/>	<input type="checkbox"/>	<input checked="" type="checkbox"/>	<input checked="" type="checkbox"/>	<input type="checkbox"/>	<input type="checkbox"/>



COLOURWAYS (IP TOPPER/CENTRE)	JET/JET	JET/IVORY	JET/STORM	ASPEN/IVORY		NAVY/PARCHMENT		JET/SAND	
SEAT COLOUR	JET	IVORY	STORM	ASPEN	IVORY	NAVY	PARCHMENT	SAND	SAND
CARPET	JET	JET	JET	ASPEN	NAVY	NAVY	SAND	JET	JET
<b>TRIM MATERIAL/ORDER CODE</b>									
Blenheim Leather	TFC	–	TES	TAB	TAC	TAG	TAH	TAE	TAF
Full Oxford Leather	TDX	TDY	TEU	–	TED	TEF	TDZ	TEK	TEC
<b>INTERIOR TRIM FINISHER</b>									
 Burr Walnut	<input type="checkbox"/>	<input type="checkbox"/>	<input type="checkbox"/>	<input type="checkbox"/>	<input type="checkbox"/>	<b>R</b>	<b>R</b>	<input checked="" type="checkbox"/>	<input checked="" type="checkbox"/>
 Cherry Wood	<input type="checkbox"/>	<b>R</b>	<input type="checkbox"/>	<input checked="" type="checkbox"/>	<input checked="" type="checkbox"/>	<input checked="" type="checkbox"/>	<input checked="" type="checkbox"/>	<b>R</b>	<b>R</b>
 Grand Black Lacquer	<input checked="" type="checkbox"/>	<input checked="" type="checkbox"/>	<input checked="" type="checkbox"/>	<input type="checkbox"/>	<input type="checkbox"/>	<input type="checkbox"/>	<input type="checkbox"/>	<input type="checkbox"/>	<input type="checkbox"/>
 Granite	<input type="checkbox"/>	<input type="checkbox"/>	<input type="checkbox"/>	<input type="checkbox"/>	<input type="checkbox"/>	<input type="checkbox"/>	<input type="checkbox"/>	<input type="checkbox"/>	<input type="checkbox"/>

■ Combination is Designer's Choice   **R** Combination is Recommended   □ Combination is Available   – Combination is Not Available



WITH ITS MASTERFUL DESIGN, RANGE ROVER VOGUE'S INTERIOR ATTAINS A PINNACLE OF LUXURY AND ELEGANCE. Real wood and leather combine to deliver an environment that is the supreme expression of taste, providing a tailor-made feel that is without equal.

## FEATURES

INTERIOR FEATURES	TDV8	TDV8 Luxury	SUPERCHARGED
7 inch, high resolution touch screen	■	■	■
Leather steering wheel, with MF switches and cruise control	■	–	–
Heated leather steering wheel, with MF switches and cruise control	–	■	■
Automatic dimming rear view mirror	■	■	■
Trip computer with selectable speed limit warning	■	■	■
Full climate control with individual settings for driver and front passenger	■	■	■
One-touch automatic control of air distribution and demisting	■	■	■
Ambient and solar sensors with exterior temperature warning	■	■	■
Pollen filter and air quality sensing for auto recirculation	■	■	■
4-zone air conditioning	–	□	□
Sunroof	■	■	■
Dual blade sunvisors	■	■	■
Blenheim leather seats	■	–	–
Full Oxford leather contour seats	–	■	■
Electric seat adjustment with memory for drivers seat	■	■	■
Heated front seats	■	–	–
Heated front and rear seats	–	■	■
Ventilated heated / cooled front seats	–	■	■
Asymmetric folding rear seat and double-hinged, removable loadspace cover	■	■	■
Twin cup holders in rear centre arm rest	■	■	■
Ski bag	–	■	■
Land Rover Venture Cam	–	■	■

■ Standard □ Option – Not Available

EXTERIOR FEATURES	TDV8	TDV8 Luxury	SUPERCHARGED
LED rear lights	■	■	■
Body-coloured bumpers	■	■	■
Satin chrome grille and side vents	■	■	–
Diamond Mesh front grille and side vents	–	–	■
Upper tailgate release controlled from push button on dash or key	■	■	■
Heated windscreen	■	■	■
Rain sensor windscreen and autolights	■	■	■
Acoustic laminated windscreen and green tinted side windows	■	■	■
Automatic dimming exterior door mirrors	–	■	■
Powerfold exterior mirrors	■	■	■
Headlamp powerwash	■	■	■
Bi-Xenon headlamps	■	■	■
Adaptive Bi-Xenon headlamps	–	■	■
Park Distance Control (PDC) front and rear	■	■	■
Rear view camera	■	■	■
Tow bar – preparation	■	■	■
Brembo Brakes	■	■	■
Rear electronic differential	□	□	■
Terrain Response	■	■	■

### IN CAR ENTERTAINMENT

Hi ICE: 11 speaker harman/kardon® system with DSP	■	–	–
Premium ICE: 14 speaker harman/kardon® surround sound system with LOGIC7	–	■	■
Hybrid digital and analogue television system	■	■	■
Premium navigation system	■	■	■
Personal Telephone Integration (PTI) system	■	■	■
Rear Seat Entertainment system	–	■	■
Auxiliary audio input	■	■	■



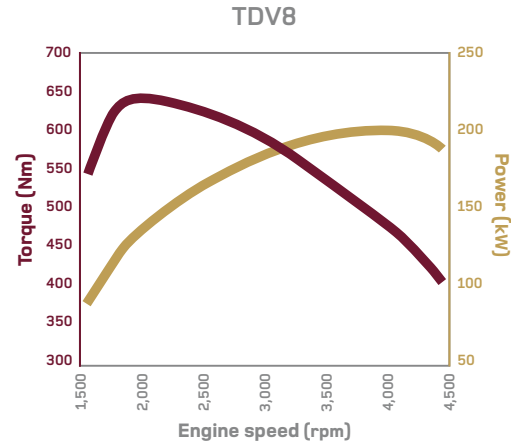
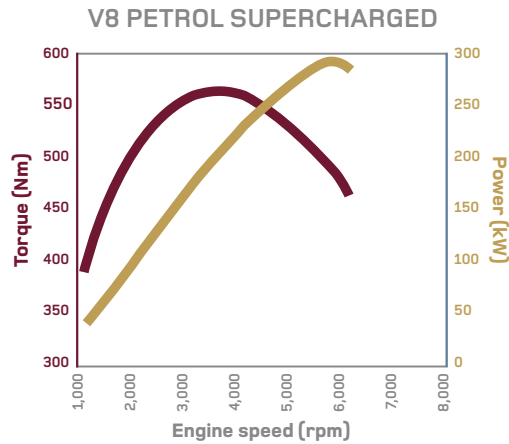

ENGINE	V8 PETROL SUPERCHARGED	TDV8
Capacity	4,197	3,630
Configuration and no. of cylinders	V8	V8
Bore (mm)	86	81
Stroke (mm)	90.3	88
Compression ratio	9.1:1	17.3:1
Cylinder head material	Aluminium	Aluminium
Cylinder block material	Aluminium	Graphite/Iron
Ignition system	Denso PAN PAG EMS Generation 1	Siemens PCR2 4
Valves per cylinder	4	4
Maximum power	291kW (396PS) 5,750rpm	200kW (271PS) 4,000rpm
Maximum torque	560Nm/3,500rpm	640Nm/2,000rpm

TRANSMISSION	ZF6HP26 (six-speed Auto)	ZF6HP26 (six-speed Auto)
Transmission type	ZF6HP26 (six-speed Auto)	ZF6HP26 (six-speed Auto)
6th	0.691	0.691
5th	0.867	0.867
4th	1.143	1.143
3rd	1.521	1.521
2nd	2.34	2.34
1st	4.171	4.171
Reverse	3.403	3.403
Final drive ratio	3.73	3.54
Transfer box ratio High	1.1	1.1
Transfer box ratio Low	2.93	2.93
Shift-on-the-move (kph/mph) High to Low	40/25	40/25
Shift-on-the-move (kph/mph) Low to High	60/37	60/37
6th High in gear speed kph/mph (rpm)	210/130 (3,722)	200/124 (3,625)
1st High kph/mph (rpm)	57/35 (6,100)	38/24 (4,000)
1st Low kph/mph (rpm)	19/12 (6,100)	13/8 (4,000)



## TECHNICAL DATA

<b>SAFETY</b>	<b>V8 PETROL SUPERCHARGED</b>	<b>TDV8</b>
Four-channel all terrain ABS power breaking with all-round ventilated disc brakes	■	■
Central high mounted stop lamp	■	■
Side impact door beams on all doors	■	■
Full size driver & front passenger side airbags	■	■
Airbags, driver & front passenger head	■	■
Airbags, driver & front passenger side	■	■
Rear outboard passenger head airbags	■	■
Drivers knee airbag	■	■
Front passenger knee bolster	■	■
Front seat belt reel mounted pre-tensioners and load limiters	■	■
Active Roll Mitigation (ARM) system	■	■

### **SUSPENSION & STEERING**

Electric air suspension with variable ride height	■	■
Speed sensitive power assisted rack and pinion steering with positive feel, hydraulic and mechanical lock stops	■	■
Electrically adjustable steering column	■	■
Steering wheel mounted ICE controls	■	■

■ Standard

<b>BRAKES</b>	<b>V8 PETROL SUPERCHARGED</b>	<b>TDV8</b>
Front size (mm)	360 x 30	360 x 30
Type	Brembo® 4-piston fixed calliper ventilated disc	Brembo® 4-piston fixed calliper ventilated disc
Rear size (mm)	354 x 20	354 x 20
Type	Sliding calliper ventilated disc	Sliding calliper ventilated disc
Parking	Duo Servo	Duo Servo

### **STEERING**

Type	Speed Proportional PAS	Speed Proportional PAS
Turns lock to lock	3.46	3.46
Turning circle (kerb to kerb)	12.0m	12.0m
Turning circle (wall to wall)	12.6m	12.6m





## DIMENSIONS AND CAPABILITY

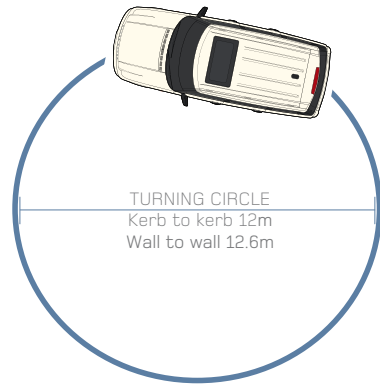

HEADROOM  
Maximum front headroom 997mm  
– identical for sunroof or  
non-sunroof vehicles  
REAR HEADROOM 974mm



GROUND CLEARANCE  
off-road height 275mm  
(Standard ride height 225mm)

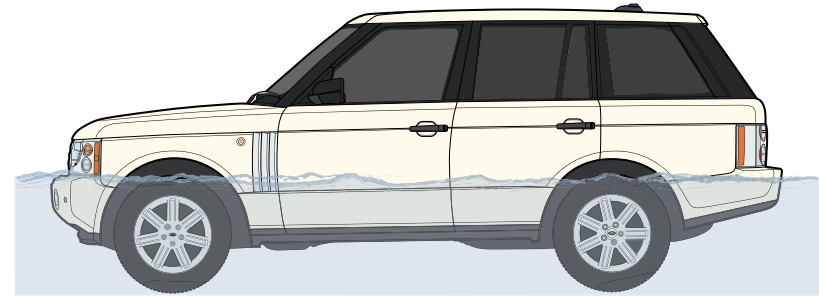

WADING DEPTH Maximum wading depth 700mm

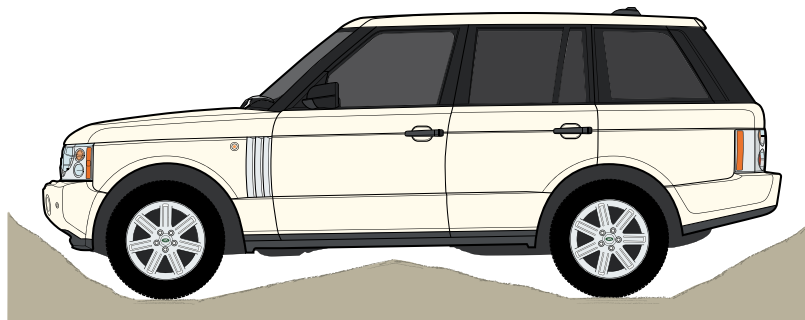

APPROACH ANGLE  
Standard ride height 29°  
off-road 34° (to spoiler)

RAMP ANGLE  
Standard ride height 25°  
off-road 30°

DEPARTURE ANGLE  
Standard ride height 24.2°  
off-road 26.6° (to bumper)



LUGGAGE CAPACITY REAR SEATS FORWARD  
Height 1,008mm Width 1,124mm  
**Loadspace volume 2,099 litres**  
Loadspace width between arches 1,040mm  
Length at floor 1,529mm  
Maximum box size (length x width x height)  
1,265 x 1,024 x 803mm



LUGGAGE CAPACITY REAR SEATS UPRIGHT  
Height 1,008mm Width 1,124mm  
**Loadspace volume 994 litres**  
Loadspace width between arches 1,040mm  
Length 1,081mm

Thanks to its innovative cross-linked air suspension, The Range Rover can maintain a level ride height even over undulating terrain and be set to lower gently to ensure easy entry and exit when parked. Despite its impressive power and peerless capabilities, front and rear Park Distance Control and speed sensitive power-assisted rack and pinion steering ensure that manoeuvring in tight spots is always a simple, trouble-free operation. And with up to 2,099 litres of cargo space Range Rover Vogue again demonstrates its breadth of capability.

## PERFORMANCE AND WEIGHTS

WEIGHTS (kg)	SUPERCHARGED V8	TDV8
Total (EEC kerb)	2,687	2,717
Gross vehicle weight	3,100	3,200
Max front axle	1,530	1,530
Max rear axle	1,850	1,850
Max roof rack (including roof rack)	100	100

TOWING (kg) (towing pack optional)	SUPERCHARGED V8	TDV8
Unbraked trailer	750	750
Trailer with over-run brakes	3,500	3,500

FUEL ECONOMY* & PERFORMANCE	SUPERCHARGED V8	TDV8
Urban L/100km	22.4 (12.6)	14.5 (19.6)
Extra urban L/100km	12.2 (23.1)	9.2 (31.2)
Combined L/100km	16.0 (17.7)	11.1 (25.3)
CO <sub>2</sub> emissions (g/km)	376	294
Maximum speed kph	210 (130)	200 (124)
0-100kph	7.5	9.2
0-60	7.1	8.6

\*Manufacturer's data according to new government test regulations.

Fuel consumption figures: The results given here do not express or imply any guarantee of the fuel consumption of any particular vehicle with which this information may be supplied. Vehicles are not individually tested and there are inevitable differences between individual vehicles of the same model. The vehicle may also incorporate particular modifications. Furthermore, the driver's style and road traffic conditions, as well as the extent to which the vehicle has been driven and the standard of maintenance, will affect its fuel consumption. Usable fuel tank capacity of 104.5 litres. Low fuel warning at 8 litres approximately.

The TDV8 fuel range (based on usable fuel tank capacity and the combined economy) exceeds 935km/585 miles and the Supercharged has an impressive 0-100kph time of 7.5 seconds. Both the fuel economy and the performance are aided by the extensive use of aluminium components that include the bonnet assembly, outer door skins and inner door construction, wheels, transmission housing and front wings.

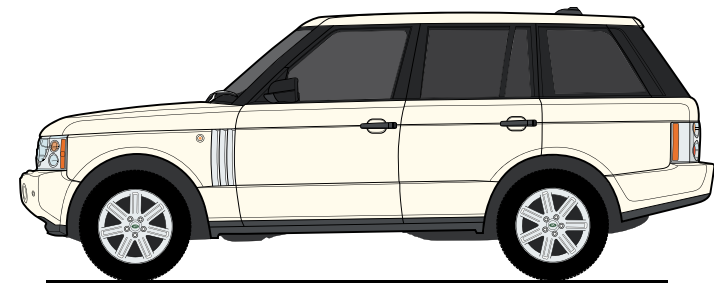

WHEELBASE 2,880mm

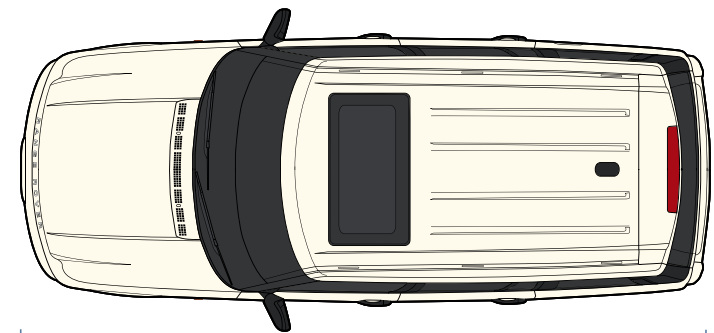

LENGTH 4,972mm

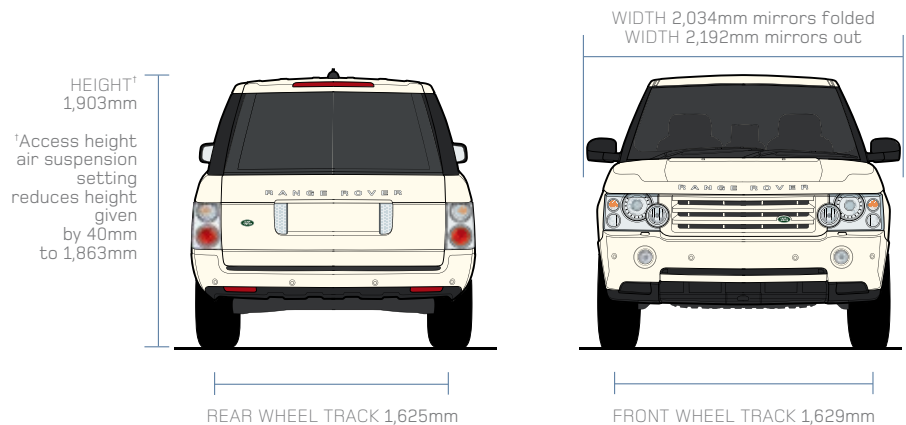





## WARRANTY, ROADSIDE ASSISTANCE, CUSTOMER CARE AND FINANCIAL SERVICES

**WARRANTY.** A comprehensive manufacturer's warranty is a feature of every Land Rover vehicle and extends to any genuine Land Rover accessories fitted by a Land Rover Retailer. The warranty period for the vehicle is three years/100,000 kilometres. In addition, the paint surface is also covered for three years/100,000 kilometres and the body work covered for corrosion for six years.

**LAND ROVER ROADSIDE ASSISTANCE.** All Land Rover vehicles purchased in Australia benefit from complimentary Land Rover Roadside Assistance service for the length of the new car warranty. This covers you Australia-wide 24 hours per day every day. And because it is Land Rover Assistance, help will also be provided if you become bogged or disabled on roads that only four-wheel drives can travel.

**CUSTOMER CARE.** Land Rover Australia has a dedicated Customer Care Centre to assist owners who may have a general query. Owners seeking this level of assistance are invited to phone our Customer Care Centre on the toll-free number 1800 625 642. Land Rover ownership includes a package of benefits designed to provide high standards of after sales care and support.

**LAND ROVER FINANCIAL SERVICES.** Just as Land Rover lets you tailor a vehicle to your specific requirements, we offer you the same service when it comes to finance. You can arrange to purchase and finance your Land Rover from the people who know it best – your Land Rover Retailer. Your Land Rover Business Manager can explain the full range of finance options available from Land Rover Financial Services and provide expert advice to help tailor a finance package to best suit your needs. To discover more about Land Rover Financial Services visit your nearest Land Rover Retailer or visit [www.landroverfinancialservices.com.au](http://www.landroverfinancialservices.com.au) or the link at [www.landrover.com.au](http://www.landrover.com.au)



**GO BEYOND**

**Important notice:** This brochure, produced by Land Rover Australia, offers a general guide to Range Rover Vogue product specifications. All details are believed to be correct as of January 2008. However, we are constantly striving for improvement and therefore reserve the right to alter specifications without notice. Accordingly this brochure should not be regarded as an infallible guide to the correct specifications, nor does it constitute an offer or sale of any particular vehicle. Distributors and retailers are not agents of Land Rover Australia and have no authority to bind Land Rover Australia to any expressed or implied undertaking or representation. Please drive responsibly off-road.

Premier Automotive Group Australia Pty Ltd  
Trading as Land Rover Australia  
ABN 86 004 352 238  
65 Epping Road, North Ryde NSW 2113  
Locked Bag 2214, North Ryde NSW 1670  
Telephone: 1800 809 308 [www.landrover.com.au](http://www.landrover.com.au)  
©Premier Automotive Group Australia Pty Ltd 2006

**Publication Number L5872 RR Vogue 08MY Brochure 28pp 01/08**