

1988



ISUZU

Bigger engines, tougher drive train and surer braking will make this versatile 4 × 4 utility vehicle your favorite companion. The perfect combination of urbane sophistication and agile, off-road excitement.

TROOPER 4WD





The TROOPER- Big Potential Pulsing Within

TROOPER's year of surprises is now emerging... surprises like the mighty heart beating within the smooth, sophisticated body... like the new, tougher undercarriage, drive train and brakes built to handle the stepped-up engine power.

TROOPER emerges from the quiet of the shadows with flash after flash of brilliance, illuminating the world of 4x4 vehicles. Brilliance in engineering... in styling... in performance... with big potential.

And all that potential is waiting for you to slip behind the wheel, to take charge, to experience a tougher and more dynamic drive than ever before. TROOPER. It can drive you anywhere.

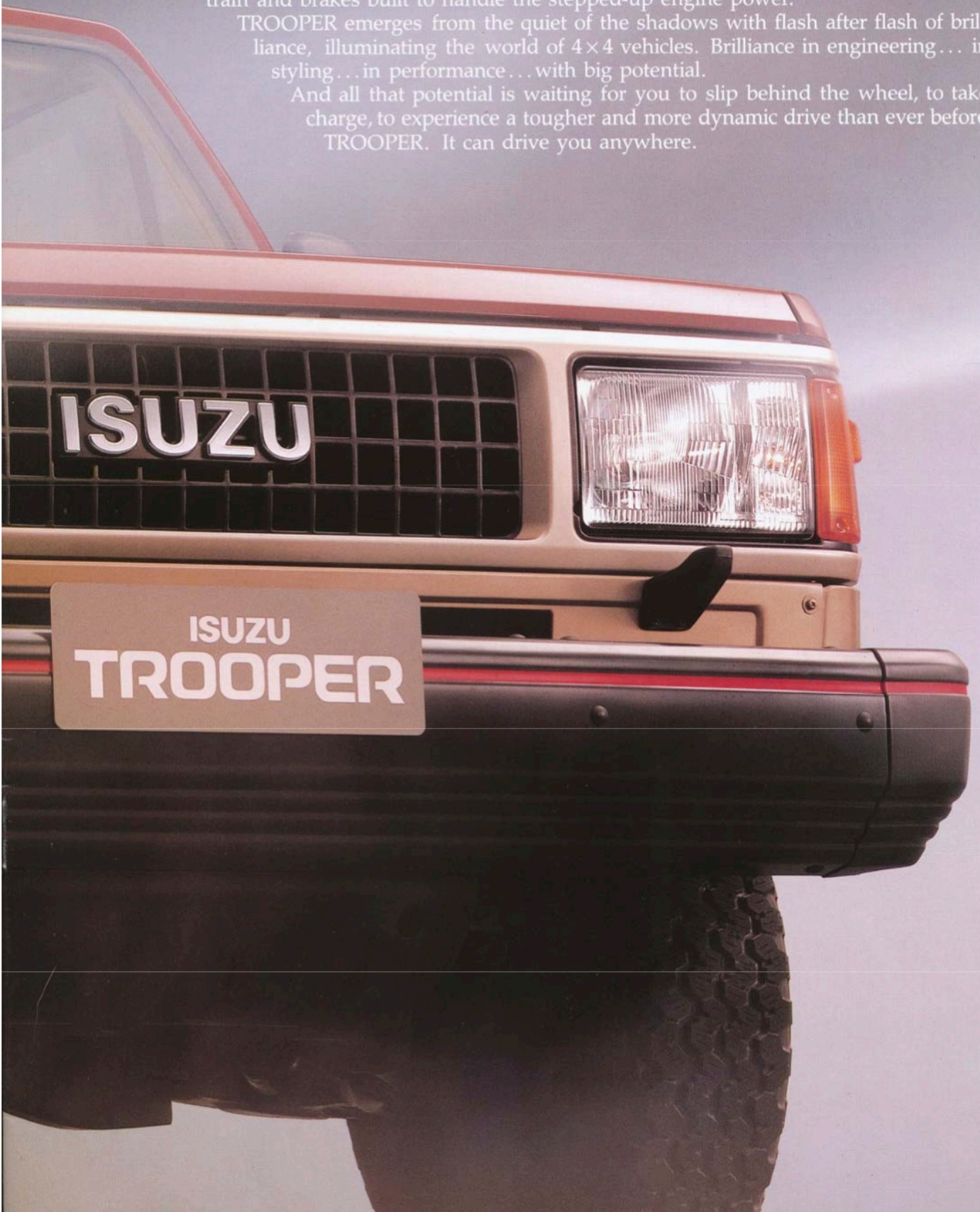



TROOPER

 ISUZU

The TROOPER-Sophisticated Styling with Worldwide Appeal

TROOPER always looks good. Sophisticated exterior styling ensures a body both functional and sleek, while the ergonomically designed interior provides safe, comfortable seating, convenient controls and a dashboard that communicates vehicle conditions at a glance. The wide selection of body colors, stripe combinations and interior accessories further enhance the TROOPER's sense of excitement and style. The comfort, the good looks and the intensely modern design go together to give you a feeling of driving-luxury unsurpassed by any 4x4 vehicle today. TROOPER. It can drive you anywhere.



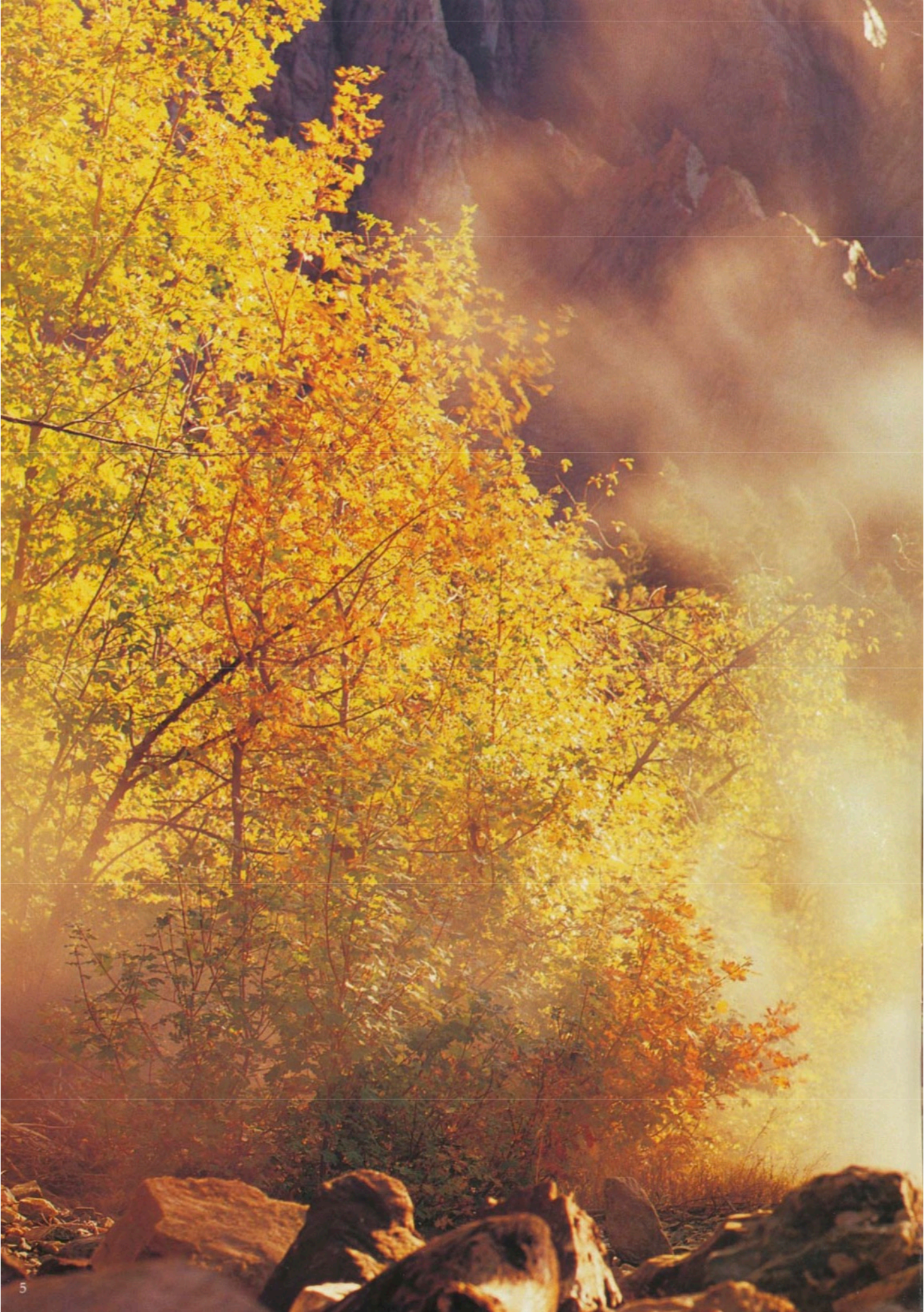

CHALLENGE-TROOPER

It can drive you anywhere.



DLX HARD TOP

TROOPER Tops Tough Conditions

Power, versatility, rugged dependability. This X-ray look inside shows how the TROOPER is built to challenge the severest terrain and come up the winner... every time. There's power: four tough, gutsy engines are strong and bold, giving you quick acceleration, steady climbing, and smooth, stable high-speed driving. And a rugged drive train and braking system ensure added safety.

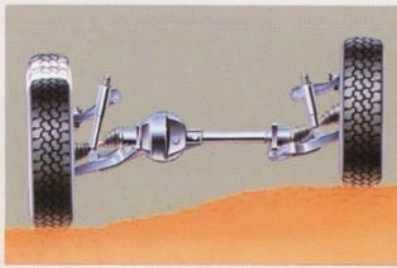

Independent double-wishbone torsion-bar front suspension

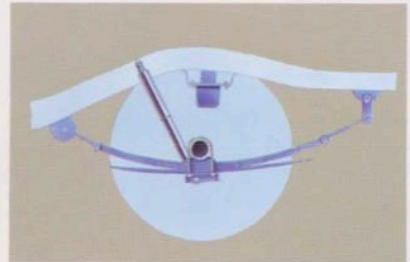

Long-travel semi-elliptical leaf springs

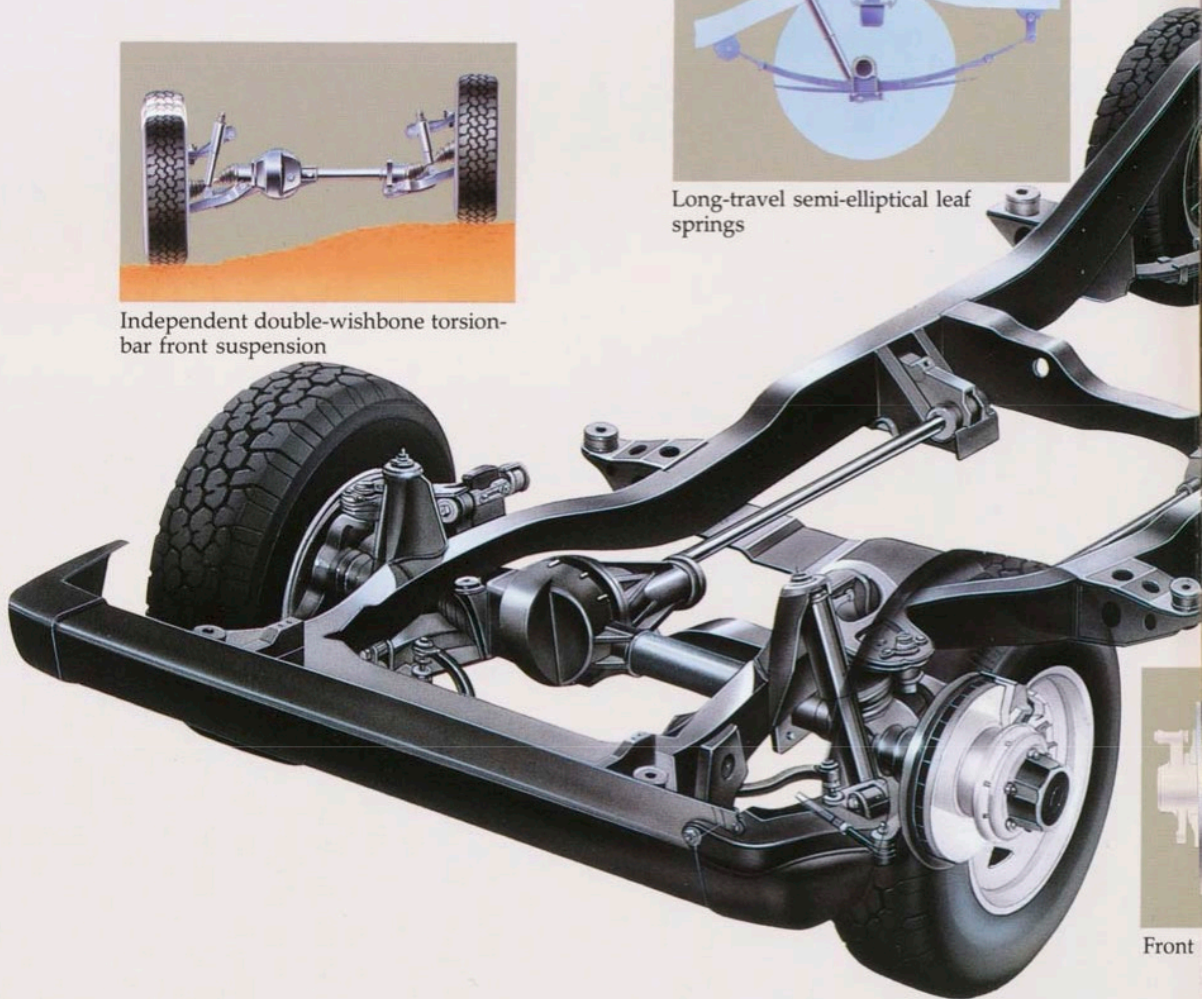

Front

Big, Bold Powerplants



4JB1-T Turbo Diesel

Improved fuel flow characteristics have boosted the power of this 2,771cc diesel engine to 100 PS at 3,800rpm. Massive turbo-powered torque delivers up to 23.0kg-m at 2,300rpm.

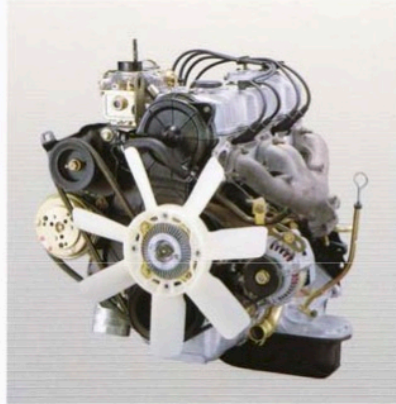

4ZE1 Gasoline

Gasoline-driven take-off and torque in a quiet, 2,559cc engine. This light-weight powerplant delivers 115 PS of high-performance power at 4,600rpm.

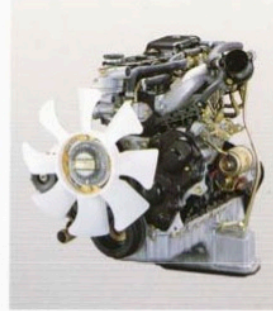

4JB1 Diesel

This direct injection 2,771cc diesel engine delivers outstanding fuel economy. Improved fuel flow characteristics turn out 87 PS at 3,800rpm.

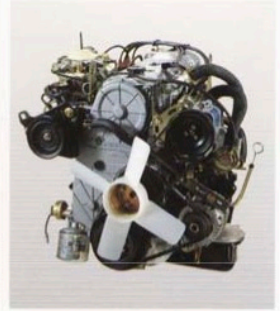

4ZD1 Gasoline

The worldwide reputation of this 2,254cc gasoline engine is well-earned. It is compact and light-weight, yet puts out a hefty 111 PS at 5,000rpm.

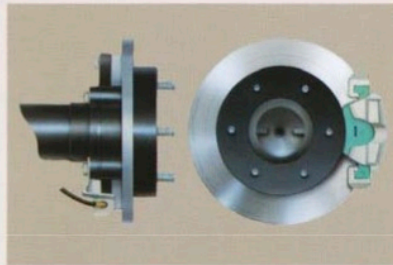
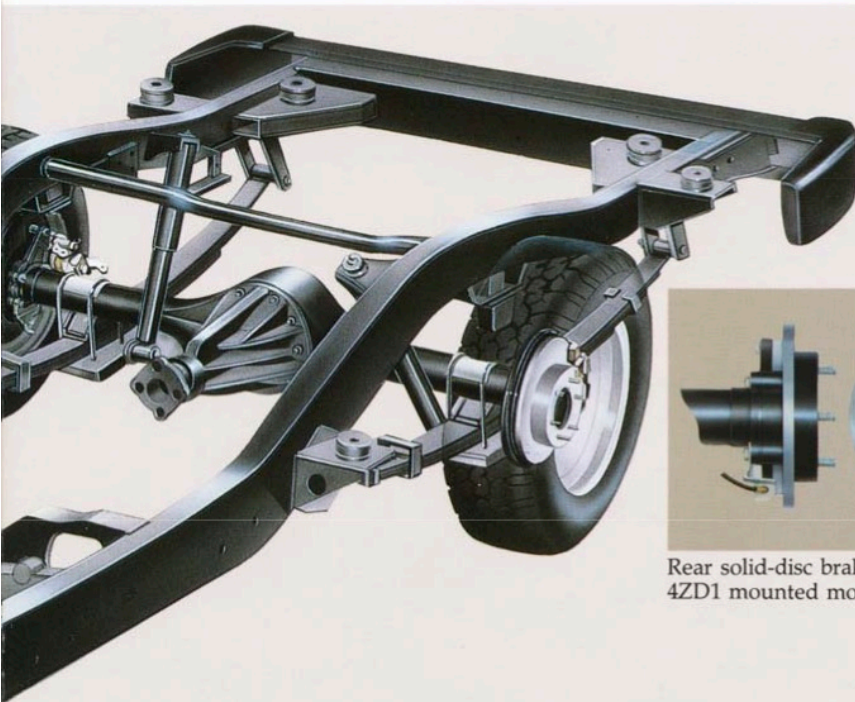

Rear solid-disc brakes (excluding the 4ZD1 mounted model)

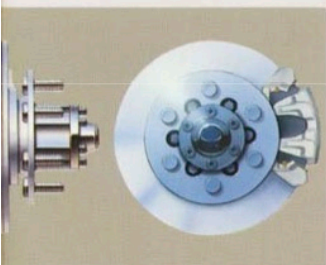

ventilated-disc brakes

Approach and departure angles



Excellent cross-slope stability



Tight turning radius





GO-TROOPER

It can drive you anywhere.



IS HARD TOP

TROOPER Takes You in Comfort

Lean back... Relax... Feel yourself being cradled in a driving environment so well planned, so luxurious, that you'll look forward to every driving experience. Notice how your hands fall naturally to each control as you need it, and your eyes quickly scan the instruments without wasted motion. You'll enjoy the quality workmanship and design as an important part of your daily life. And you'll feel the natural sense of pride that comes from owning excellence.



Control is in Your Hands

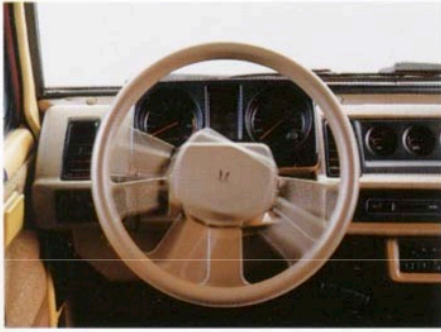

TROOPER's power steering system gives you an extra edge of control for tackling any situation, from seaside to mountain side. Leaves you the full excitement of driving, while taking over the hard work.



Warning indicators for gasoline engine model graphically show you at a glance the most important factors of your TROOPER's operating condition. Vehicle safety and dependability are safeguarded; you always know what's happening when you drive.



The smoothly spaced gear ratios of this 5-speed precision transmission turns out smooth driving on the road, and rugged dirt-grabbing traction off-road is provided by a tough 2-speed transfer box.



LS WAGON



RELAX-TROOPER

It can drive you anywhere.



ES WAGON
Front bar is locally supplied.

Hard Travel Goes Easy

Everybody will rest easy in the TROOPER. Comfortable, ergonomically designed seats provide the kind of pleasant support you'd only expect from your easy chair. Hard driving over any terrain becomes more pleasurable than ever when driver and passenger alike arrive at the destination rested and ready for excitement. And as you drive, you'll like the way your hand rests naturally on each control while every dial and indicator is clearly visible.



4 Versatile Rear Seating Arrangements (For LS Wagon)



Each seat reclines independently so that each passenger can adjust the seat angle for personal comfort.



Fold down the narrower rear seat and haul long cargo beside the passengers.



Recline both front and rear seats fully, and make a full-length bed. Perfect for overnight stops.



Fold both rear seats forward for maximum cargo space and easy access.



LS WAGON

Expandable Convenience

TROOPER is available with a wide range of optional and standard features to expand usefulness and increase versatility. Choose the body color, accent stripe, wheel cover and interior grade you like. Other options, such as headlamp washer, instrument cluster, and rear wiper-washer and defogger further enhance TROOPER's capabilities.



Body Color and Stripe Combinations



Body Color	Stripe (TYPE-D)		Stripe (TYPE-E)		Pin Stripe
	Reddish	Greenish	Reddish	Greenish	Red
PURE WHITE	●	●	●	●	—
PARTHENON IVORY	●	●	●	●	—
CAVALIER BLUE	●	●	●	●	—
SPECTRA RED	●	●	●	●	—
DARK FIRE OPAL	●	●	●	●	—
HOLLY GREEN	●	●	●	●	—
HAZEL NUT METALLIC	●	●	●	●	—
PEWTER METALLIC	●	●	●	●	—
HYPER SILVER METALLIC	●	●	●	●	—
SEASIDE BEIGE METALLIC	●	●	●	●	—
*CAVALIER BLUE/ HYPER SILVER METALLIC	—	—	—	—	●
*PURE WHITE/ SEASIDE BEIGE METALLIC	—	—	—	—	●
*DARK FIRE OPAL/ SEASIDE BEIGE METALLIC	—	—	—	—	●

*mark means 2-tone body color.
Pin stripe is standard equipment for 2-tone body color.



Options Some features are standard depending on grade (LS, DLX)



Headlamp washer



Spare fuel tank



Bench seat



Rear wiper-washer and defogger combination



Automatic free-wheeling hubs with styled wheel



Aluminum wheel



Combination meter (Altitude/Climo/Voltage)



Air conditioner and sub meters



Digital quartz clock in center console



AM/FM radio with cassette player

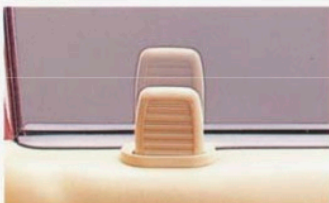

Auto door lock mechanism



Power window switch

The Right TROOPER for You

Take plenty of time. Check all the different choices. There is a combination that's perfect for you. Two wheelbase lengths can provide either large passenger and cargo capacity, or agile maneuverability. And three different body types plus three grades of luxury make the possibilities even more fascinating. There's a TROOPER just made for you.



HARD TOP



WAGON

Five, 7, 9 adults sit comfortably in this luxurious long-wheelbase TROOPER.





This short-wheelbase TROOPER delivers excitement and rugged agility anywhere you go.



SOFT TOP

Go open-air or enclosed-top. Short-wheelbase gives you sporty good looks.

3 Levels of Luxury

LS (WAGON & HARD TOP)

The most luxurious and the most highly equipped grade.

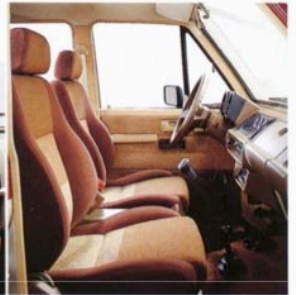

DLX (WAGON & HARD TOP)

The intermediate grade is well-equipped and luxurious.

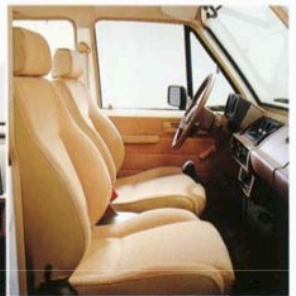

STD (WAGON, HARD TOP & SOFT TOP)

The basic grade vehicle for standard, dependable transportation.

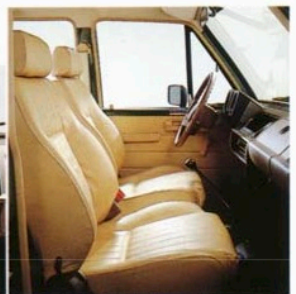

Headrest optional

WAGON

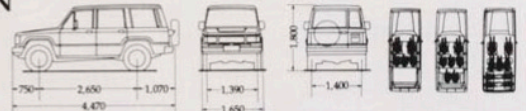

HARD TOP

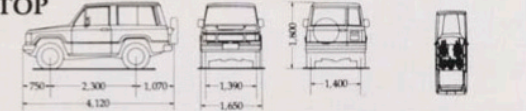

SOFT TOP

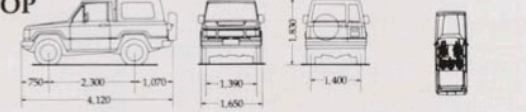

Unit: mm

EQUIPMENT

The equipment below may differ depending on the local market.

ITEM	MODEL	BODY TYPE	WAGON			HARD TOP			SOFT TOP
			GRADE	STD	DLX	LS	STD	DLX	LS
OPERATION	Power Steering		○	●	●	○	●	●	○
	Rear Axle with Limited Slip Differential		○	○	○	○	○	○	○
	Free Wheeling Hubs	Manual	○	○	○	○	○	○	○
Automatic		○	○	○	○	○	○	○	
FUEL	Fuel Low Level Warning Indicator		●	●	●	●	●	●	●
	Spare Fuel Tank: 20ℓ		○	○	○	○	○	○	○
AIR CONTROL	Heater & Defroster		○	○	○	○	○	○	○
	Air Conditioner		○	○	○	○	○	○	○
AUDIO	AM Radio		○	○	—	○	○	—	○
	AM/FM Cassette Player: 4 Speaker (2 Speaker Only for Soft Top)		○	○	●	○	○	●	○
INTERIOR	Steering Wheel	2-Spoke Wheel	●	●	—	●	●	—	●
		Sports Type	—	○	●	—	○	●	—
	Tachometer & Sub Meters (Water Temp., Fuel & Oil Press.)		—	○	●	—	○	●	—
	Digital Clock with Center Console		—	○	●	—	○	●	—
	Seat Belt	Front: 3 Point (2 Point for Soft Top)	○	●	●	○	●	●	○
		Rear: 2 Point	○	●	●	○	●	●	○
	Shift Knob	Standard Type	●	—	—	●	—	—	●
		Deluxe Type	—	●	●	—	●	●	—
	Brake Fluid Level Warning Indicator		●	●	●	●	●	●	●
	Combination Meter (Altitude/Clino/Thermo or Volt)		—	○	●	—	○	●	—
Bench Seats: 9 Passengers		○	○	○	—	—	—	—	
Third Seats: 7 Passengers		—	○	○	—	—	—	—	
EXTERIOR	Styled Wheels		○	●	●	○	●	●	○
	Aluminum Alloy Styled Wheels		—	○	○	—	○	○	—
	Rear Step Bumper		○	○	●	○	○	●	○
	Body Side Protector Moulding		○	○	●	○	○	●	○
	Body Stripe		○	○	○	○	○	○	○
	Spare Tire Cover		●	●	●	●	●	●	●
	Radiator Grille Guard		○	○	○	○	○	○	○
	Laminated Windshield Glass		○	●	●	○	●	●	○
	Engine Hood Ornament		○	○	○	○	○	○	○
	Tow Hook; Front & Rear		●	●	●	●	●	●	●
Splash Guard; Rear		●	●	●	●	●	●	●	
Bright Parts Package		○	○	○	○	○	○	○	
BODY CONFIGURATION	High Roof		○	○	○	—	—	—	—
ELECTRICAL	Power Window		—	○	○	—	—	—	—
	Automatic Door Lock		—	○	●	—	○	●	—
	Rear Wiper, Washer & Defogger		○	●	●	○	●	●	—
	Electrical Winch		○	○	○	○	○	○	○
	Headlamp Washer		○	○	○	○	○	○	○
Fog Lamp: Halogen		○	○	○	○	○	○	○	

●=Standard ○=Option

EXTERIOR BODY COLORS

BODY COLOR	INTERIOR COLOR	STD	DLX		LS	
		Beige	Beige	Gray	Beige	Gray
PURE WHITE		●	●	—	●	—
PARTHENON IVORY		●	●	—	—	—
CAVALIER BLUE		●	—	●	—	—
SPECTRA RED		●	—	●	—	—
DARK FIRE OPAL		●	●	—	—	—
HOLLY GREEN		●	●	—	●	—
*HAZEL NUT METALLIC		●	●	—	—	—
*PEWTER METALLIC		●	—	●	—	●
*HYPER SILVER METALLIC		●	—	●	—	●
*SEASIDE BEIGE METALLIC		●	●	—	●	—
*CAVALIER BLUE/HYPER SILVER METALLIC		—	—	—	—	●
*PURE WHITE/SEASIDE BEIGE METALLIC		—	—	—	●	—
*DARK FIRE OPAL/SEASIDE BEIGE METALLIC		—	—	—	●	—

NOTE: (1) Exterior colors with *mark are extra costs. (2) Actual exterior color may vary slightly from the color printed in this chart.

SPECIFICATIONS

ITEM	MODEL	WAGON				HARD TOP				SOFT TOP			
		4ZE1 Gasoline	4ZD1 Gasoline	4JB1-T Turbo Diesel	4JB1 Diesel	4ZE1 Gasoline	4ZD1 Gasoline	4JB1-T Turbo Diesel	4JB1 Diesel	4ZE1 Gasoline	4ZD1 Gasoline	4JB1-T Turbo Diesel	4JB1 Diesel
ENGINE	Type	4cyl., in-line SOHC		4cyl., in-line OHV		4cyl., in-line SOHC		4cyl., in-line OHV		4cyl., in-line SOHC		4cyl., in-line OHV	
	Bore × stroke mm (in)	92.6 × 95 (3.65 × 3.74)	89.3 × 90.0 (3.52 × 3.55)	93 × 102 (3.66 × 4.02)		92.6 × 95 (3.65 × 3.74)	89.3 × 90.0 (3.52 × 3.55)	93 × 102 (3.66 × 4.02)		92.6 × 95 (3.65 × 3.74)	89.3 × 90.0 (3.52 × 3.55)	93 × 102 (3.66 × 4.02)	
	Displacement cc (cu. in.)	2,559 (156.1)	2,254 (137.5)	2,771 (169)		2,559 (156.1)	2,254 (137.5)	2,771 (169)		2,559 (156.1)	2,254 (137.5)	2,771 (169)	
	Max. output (DIN) kw (PS)/rpm	85 (115)/4,600	82 (111)/5,000	74 (100)/3,800	64 (87)/3,800	85 (115)/4,600	82 (111)/5,000	74 (100)/3,800	64 (87)/3,800	85 (115)/4,600	82 (111)/5,000	74 (100)/3,800	64 (87)/3,800
	Max. torque (DIN) N.m. (kg. m)/rpm	195 (20.0)/2,600	185 (18.9)/3,000	225 (23.0)/2,300	180 (18.5)/2,300	195 (20.0)/2,600	185 (18.9)/3,000	225 (23.0)/2,300	180 (18.5)/2,300	195 (20.0)/2,600	185 (18.9)/3,000	225 (23.0)/2,300	180 (18.5)/2,300
	Compression ratio (to 1)	8.3		17.5	18.2	8.3		17.5	18.2	8.3		17.5	18.2
FUEL	Type	2-barrel carburetor		Bosch "VE" distributor type fuel injection		2-barrel carburetor		Bosch "VE" distributor type fuel injection		2-barrel carburetor		Bosch "VE" distributor type fuel injection	
	Tank capacity lit. (U.S. gal)	83 (21.9)											
SUSPENSION	Front	Independent double wishbone arms, torsion bar springs with stabilizer bar											
	Rear	Semi-elliptical alloy steel leaf springs											
TRANSMISSION	Type	5-speed overdrive											
	Gear ratio	(4ZD1) 1st 3.785, 2nd 2.171, 3rd 1.413, 4th 1.000, 5th 0.855, REV. 3.720 (4ZE1/4JB1/4JB1-T) 1st 3.767, 2nd 2.314, 3rd 1.404, 4th 1.000, 5th 0.809, REV. 3.873											
FINAL GEAR RATIO	4ZE1, 4ZD1; 41/9 (4.555) 4JB1, 4JB1-T; 43/10 (4.300)												
BRAKES	4ZD1; Hydraulic with vacuum assist, front ventilated disc, leading/trailing rear drum 4ZE1, 4JB1, 4JB1-T; Hydraulic with vacuum assist, front ventilated disc, rear solid disc												
CLUTCH	Diaphragm pressure spring and dry single plate with cushioning springs												
TRANSFER	2-speed transfer case on right side of transmission, Gear ratio: High; 1.000 Low; 1.870 (4ZD1), High; 1.000 Low; 2.283 (4ZE1/4JB1/4JB1-T)												
STEERING	Recirculating ball, manual, collapsible												
TIRES & DISC WHEELS	STD 6.00-16-6 and 4.5E × 16, DLX/LS H78-15-4PR & 6J × 15 styled wheel												

WEIGHT, DIMENSIONS AND PERFORMANCE

ITEM	MODEL	WAGON				HARD TOP				SOFT TOP			
		4ZE1 Gasoline	4ZD1 Gasoline	4JB1-T Turbo Diesel	4JB1 Diesel	4ZE1 Gasoline	4ZD1 Gasoline	4JB1-T Turbo Diesel	4JB1 Diesel	4ZE1 Gasoline	4ZD1 Gasoline	4JB1-T Turbo Diesel	4JB1 Diesel
DIMENSIONS	Overall length mm (in.)	4,470 (176.0)				4,120 (162.2)							
	Overall width mm (in.)	1,650 (65.0)											
	Overall height mm (in.)	1,800 (70.9)						1,830 (72.0)					
	Wheelbase mm (in.)	2,650 (104.3)				2,300 (100.6)							
	Front overhang mm (in.)	750 (29.5)											
	Rear overhang mm (in.)	1,070 (42.1)											
	Tread (front) mm (in.)	1,390 (54.7)											
	Tread (rear) mm (in.)	1,400 (55.1)											
	Min. ground clearance mm (in.)	225 (8.9)											
WEIGHTS	G.V.M kg (lbs.)	2,150 (4,740)											
	Vehicle weight kg (lbs.)	1,545 (3,405)	1,480 (3,265)	1,645 (3,625)	1,630 (3,595)	1,485 (3,275)	1,415 (3,120)	1,585 (3,495)	1,570 (3,460)	1,430 (3,155)	1,360 (3,000)	1,530 (3,375)	1,515 (3,340)
PERFORMANCE	Turning radius m (ft.)	5.4 (17.7)				4.8 (15.7)							
	Approach angle deg.	43											
	Departure angle deg.	32											
	Ramp breakover angle deg.	30				33							

ISUZU MOTORS LIMITED reserves the right to change specifications and equipment without notice.
Details of specifications and equipment are also subject to change to meet local conditions and government requirements.
Please inquire at your local ISUZU dealer for more complete details of any such changes that may be required.
Note: Actual vehicle body colors may vary slightly from the colors of the photographs printed in the catalog.



ISUZU MOTORS LIMITED

Tokyo, Japan