

QX70

 INFINITI

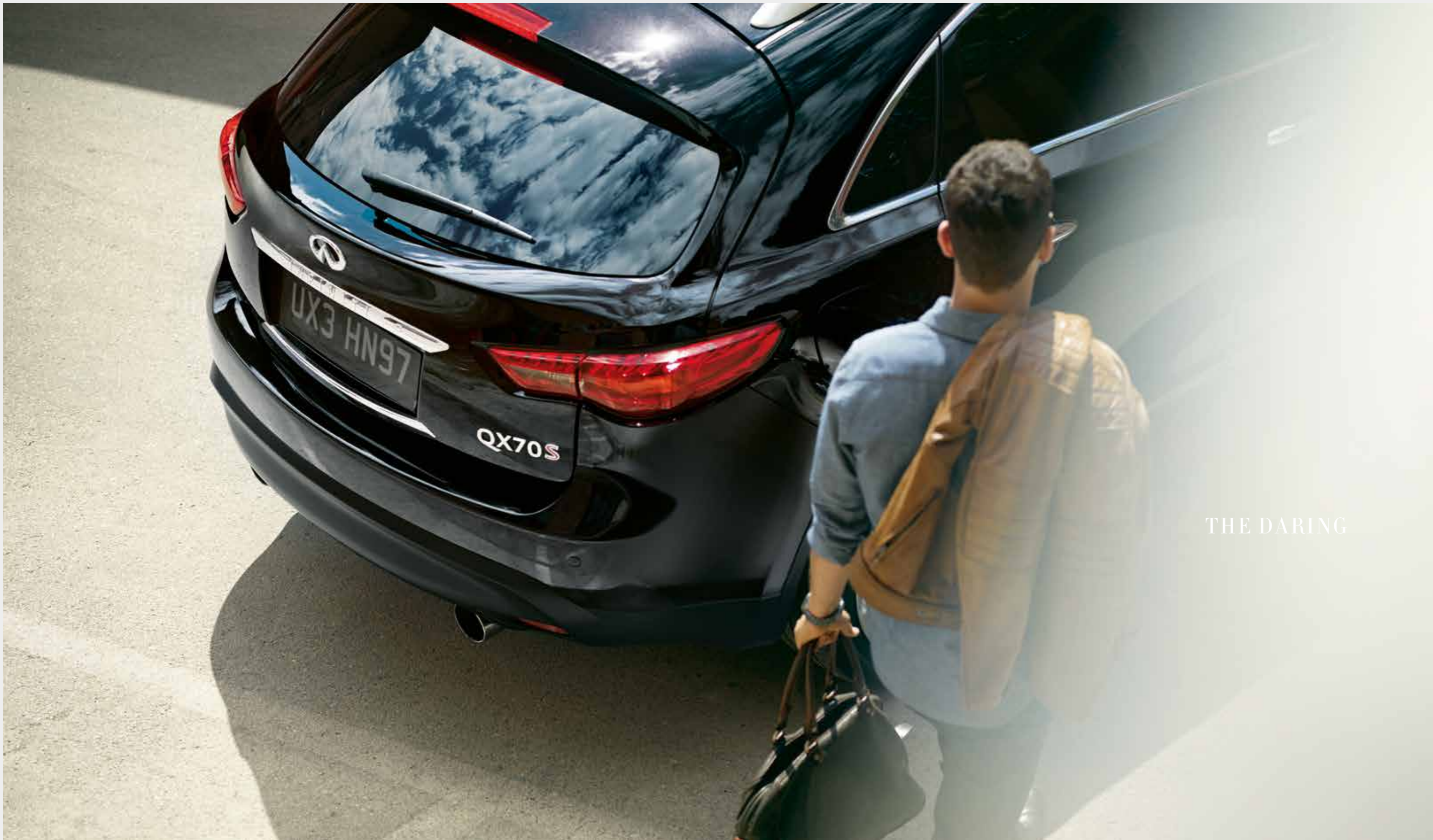



THE DARING

The vehicle that continues to break new ground between sport, utility and modern art, the Infiniti QX70 escapes all classification. It's a luxury crossover of high reward, unabashedly bold design and surprising versatility. And yet, it's motivated by the soul of a sports car. Uncompromising in its vision, it's a manifesto in motion proclaiming that some are satisfied only when they write their own rules.

THE EXCEPTION



A rare few move through the world with a confidence borne of intelligence and speed. An acute sense of relaxed readiness stemming from technology that is always on the lookout. When you're prepared, you're in total control.

FORWARD COLLISION WARNING (FCW)¹ scans ahead with laser sensors to help warn you of a potential collision and can trigger Intelligent Brake Assist (IBA) to apply the brakes to help minimise an unavoidable collision.

LANE DEPARTURE PREVENTION (LDP) watches road markings with a camera and can subtly apply the brakes to help keep your vehicle from unintentionally drifting from your lane. Traffic may surround you, but so will confidence.

INTELLIGENT CRUISE CONTROL (ICC) automatically reduces your speed when the traffic in front of you slows down. When the way is clear, it accelerates back to your desired speed. Less effort, more ease.



THE POWER

Don't waste the opportunity for excitement that lives in every moment. With performance at the core of the QX70, the rush is always ready. Experienced every time you open the throttle, our unique take on engineering gives acceleration an emotional quality that goes beyond pure speed.

SIGNATURE EXHAUST NOTE enhances your driving experience with a thrilling growl. Even with your eyes closed, the QX70 will be hard to mistake.

ACCELERATION SWELL transforms mechanical power into emotional excitement. Precise engine tuning unleashes torque over a broader rev range, and the feeling of acceleration is shaped to increase the faster you go.



INFINITI HARD DRIVE NAVIGATION SYSTEM offers a more intuitive view and interface for increased ease and confidence, helping you expertly find your location and your destination, even in crowded city environs.

ADAPTIVE FRONT-LIGHTING SYSTEM (AFS) turns your headlights to shed light on where you're steering, helping heighten visibility as you manoeuvre. The Bi-Xenon headlights of the QX70 do more than impress – they respond to your needs.



Love straights but devour curves. Each turn is met with immediacy and the g-forces sustained with a tenacity that reveals its athletic nature. With surprising poise and responsiveness, you'll experience design that redefines the crossover.



THE INTENSE

CONTINUOUS DAMPING CONTROL (CDC) automatically adjusts the suspension to deliver stability, control and comfort. In Sport Mode, the suspension firms for the most immediate response.

DOWNSHIFT REV MATCHING expertly translates performance driving technique. Flick the magnesium paddle shifter for a lower gear and it blips the throttle to ready the engine for the new gear. Smoother, quicker downshifts mean balance and response.



THE REWARD

21-INCH ALLOY WHEELS are designed to heighten both performance and visual appeal. They fuse the function of lightweight construction with the raw force of personality.

INFINITI INTELLIGENT KEY Keep it in your pocket or purse, and the seat and mirrors are adjusted to your personal preferences. The ignition button will even illuminate, pulsing like a heartbeat, to let you know it's ready to please and to excite.



OBJECT OF ATTRACTION

INFINITI QX70

AMBIANCE

A welcoming and evocative space is measured by its ability to stir your emotions.



-0.6_{MM}
OFFSET

OPTICAL PERFECTION Where interior components meet – where the dashboard meets the door or the centre console – they are assembled not to be mathematically perfect, but to look perfect. This requires an exacting manufacturing process, tightening the space where dashboard meets door from 3 mm to 2.4 mm in order to achieve a seamless visual design from the driver's point of view. But we believe in considering every angle in creating an emotionally transcendent environment.



LEATHER SEATS The soft leather offers an exquisite and natural feel, like luxury furniture, a sheer masterpiece of quality and texture.

INVITING YOU IN We use light not just to make you feel more secure, but to make you feel like an honoured guest. Welcome Lighting responds to your presence automatically by gently illuminating the puddle lights. Then, as you get closer, the interior lights are illuminated. This choreographed sequence ends with the Start/Stop Button, pulsing as though with a heartbeat – inviting you to bring your QX70 to life and building anticipation for the road ahead.

EVERY BREATH FRESHER AND CLEANER Even the invisible is never overlooked. The Advanced Climate Control System features the dual-zone adaptive climate control with auto-recirculation. It works in concert with the Grape Polyphenol Filter, which removes up to 99.5% of allergens from the air coming in from the outside.

POWER

Award-winning build quality, fuel efficiency and output can be measured with instruments or graphs, but the true excellence of Infiniti engines is in the feeling unleashed as you drive.



390
PS

13.5*
l/100 km
20.9
mpg

5.0-LITRE V8 ENGINE is a torrent just waiting for you to unleash it. Every touch of the throttle puts a massive 390 PS and 500 Nm of torque at your disposal, and natural aspiration means that the power comes on with a thrilling immediacy. Yet, acceleration is only one component. Its power is shaped to feel limitless. Its roar – unforgettable.

320
PS

12.1*
l/100 km
22.4
mpg

3.7-LITRE V6 ENGINE is a potent blend of exciting response and intelligent efficiency. Benefitting from Variable Valve Event and Lift (VVEL) technology, the engine adjusts on the fly to make the most of every bit of fuel and every breath it takes. The result is a stirring 320 PS that still manages to achieve up to 9.4 l/100km (30 mpg)**.

238
PS

8.6*
l/100 km
32.8
mpg

6-CYLINDER DIRECT INJECTION TURBO DIESEL ENGINE*** is a refined 3.0-litre V6 direct injection powerhouse that delivers 550 Nm of torque, maximising overtaking performance. It's paired with a 7-speed automatic transmission that adapts to your driving style.

* This figure refers to the lowest combined fuel consumption available.

** This figure refers to the extra-urban fuel efficiency.

*** EU: The QX70 3.0d is subject to availability from existing stock (availability is limited). The car can no longer be imported into the EU after 31/08/2015, and generally must be registered before 31/08/2015. Speak to your dealer for more information.
Switzerland: The QX70 3.0d is subject to availability from existing stock (availability is limited). The car must be imported and registered before 31/08/2015. Speak to your dealer for more information.

5.0 390 500
Litres PS Nm

PERFORM

On its surface you'll find spacious luxury. At its foundation – the thrilling dynamics of Infiniti Direct Response performance engineering.

47%
REAR

53%
FRONT



INNATELY RESPONSIVE BALANCE The engineering philosophy behind Infiniti performance saloons, the Front-Midship Platform, also underlies the design of the QX70. Placing the engine just behind the front wheel centreline creates a near-equal front-to-rear weight ratio, with a slight front bias that you'll feel as quicker turn-in and even balance as you accelerate out of a corner. Precision and engagement that belie its crossover proportions.



ALWAYS THE PERFECT RIDE Tight corners. Rough roads. Continuous Damping Control (CDC) helps maintain the perfect balance of smoothness and response in your car. The system monitors body roll and road impacts, sending the information received to each individual shock absorber and adjusting it to the ideal level. If you want to really feel the road, select Sport mode, which firms up the ride for maximum response.



MAXIMISING POTENTIAL Better power and efficiency depends on better breathing, so our exclusive VVEL (Variable Valve Event and Lift) technology improves performance while delivering enhanced engine efficiency. VVEL continually adjusts not just when intake valves open, but also how much. It delivers a quicker response and broader torque curve, while improving fuel efficiency and lowering carbon emissions up to 10%.



CONTROL WITHOUT COMPROMISE When conditions are ideal, Intelligent All-Wheel Drive sends 100% of the power to the rear wheels for sportier response and performance. But it also constantly monitors wheelspin, throttle position and vehicle speed, and can divert up to 50% of the available power to the front wheels to enhance traction and control when conditions are less than ideal. Your need for control and your desire for excitement are both satisfied.



TIGHTER TURNS Rear Active Steer (RAS) sharpens handling and increases precision by actively turning the rear wheels as you manoeuvre. By tightening response in every corner and curve, it helps you take full advantage of the surprising balance and poise of the QX70.



THE SOUND OF PERFORMANCE A performance car speaks to you through its exhaust, and the specialty exhaust tuning on the QX70 shapes that sound into something uniquely compelling. Not only does it make an Infiniti unmistakable, it makes every trip up and down the rev counter an experience that transcends engineering and enters the realm of pure emotion.



LIGHT ON ITS FEET These stunning 21-inch alloy wheels heighten both the looks and performance of the QX70. Lightweight, thanks to both material and design, they reduce the unsprung weight. That reduction of mass makes driving more exciting by allowing the suspension to be more finely tuned and by making the handling of the QX70 more responsive. It even increases fuel efficiency.

ASSIST/ENTERTAIN

Infiniti InSuite™ integrates a host of intuitive technologies to simplify tasks and anticipate your needs as they keep you in touch with and in control of your world.

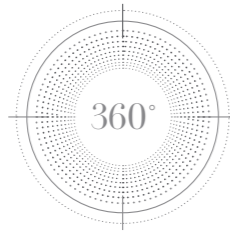

ALL-AROUND AWARENESS The Around View Monitor (AVM) with corner parking sensors, Moving Object Detection (MOD) and parking guidance gives you exceptional awareness of your environment as you park. You'll see a simulated 360° view from above, showing you clearly the objects detected around your car. And the system will even alert you to moving objects detected in your vicinity. It helps put you intuitively in control of your surroundings, while simultaneously putting you at ease.



EASE IN TRAFFIC Intelligent Cruise Control (ICC) with Low Speed Following (LSF) allows you to choose your desired speed, and automatically slows your vehicle in slowing traffic, going all the way to a complete stop. Then, as traffic flow picks up again, it re-accelerates your vehicle to your preset speed.



SECURING YOUR SPACE Distance Control Assist (DCA) employs radar to monitor the distance between you and the vehicle in front of you. And, working in concert with the innovative Intelligent Cruise Control (ICC), it allows you to select a preset following distance. It automatically engages the brakes when the traffic slows, and re-accelerates when the way clears.



A SMARTER WAY TO SEE The Adaptive Front-lighting System (AFS) on the QX70 lights not just the way ahead, but around as well. It directs light towards corners by turning the headlights in coordination with input from the steering to help the driver see upcoming vehicles and pedestrians, and to help you reach your destination safely.



A BETTER VIEW OF YOUR WORLD Infiniti Hard Drive Navigation System is packed with advanced yet intuitive technology that makes it both more informative and easier to use. Birdview perspective control gives you a more natural view of the map, while 3-D building graphics make it easy to locate your destination in crowded urban environments. Also, you can simply speak your instructions to the system, thanks to full integration with Infiniti Voice Recognition².



AUDITORY INDULGENCE With 11 speakers, including two subwoofers, the Bose® Premium Sound System delivers your music with captivating depth and astonishing clarity. Optimised for the interior of the QX70, it will create precisely the mood you desire, wherever you go. You'll also enjoy greater choice: play CDs, or stream music from a compatible Bluetooth® device or connect and control your iPod via the USB port.



POWER REAR LIFTGATE is where space meets ease and elegance. It opens and closes automatically with the push of a button on the liftgate handle or the dashboard.

PROTECTION

The Infiniti Safety Shield® concept – our comprehensive approach to safety – layers technologies to monitor conditions, help you avoid a collision, and help protect you and your passengers if one occurs.

STRONGER AND LIGHTER Ultra-high-strength steel is used in areas critical to preserving your safety in the case of a collision. The unique process used to create this material can give it more than twice the tensile strength of conventional steel. Not only does this ultra-strong material add to the vehicle's resiliency, it allows us to make the vehicle lighter overall.

1,350 MPa
ULTRA-HIGH
TENSILE STEEL

590 MPa
CONVENTIONAL
STEEL



BETTER STABILITY WHILE STOPPING Electronic Brake force Distribution (EBD) adjusts the amount of brake force applied to the front and rear wheels for improved braking performance. It not only helps the brakes wear more evenly, it reduces front-end “dive” during heavy braking, helping increase the stability of your vehicle. The system also detects vehicle-load conditions, and distributes additional brake pressure to the rear brakes as needed.

ALWAYS LOOKING FOR DANGER Intelligent Brake Assist (IBA) with Forward Collision Warning (FCW)¹ uses radar to continuously monitor and analyse your closing speed to the vehicle ahead of you, helping detect an imminent collision. It provides a two-stage warning to alert the driver as the vehicle moves towards impact and – if needed – can automatically apply the brakes to help reduce the impact speed.

MAINTAINING YOUR LANE The Lane Departure Prevention System (LDP) uses a camera to monitor for departure from the travel lane when you haven't signalled, and audibly warns you if it's detected. Then, if the drift continues, the system lightly applies selected brakes to help ease your vehicle back into the travel lane. But you never give up control. It's designed to assist, not override.

KEEPING YOU IN CONTROL Comparing actual vehicle cornering performance to the driver's input, Vehicle Dynamic Control (VDC) adjusts power levels and applies appropriate brake pressure to individual wheels to help correct oversteer or understeer, helping keep the vehicle on the steered path. Working in tandem, the Traction Control System (TCS) senses wheelspin and automatically helps give you a surer foothold.



PREPARED TO PROTECT Under certain braking conditions or when the Intelligent Brake Assist (IBA) system is activated without brake pedal input, the Front-seat Pre-Crash Seat Belts automatically tighten the front seat belts – helping restrain you and helping to maximise the effectiveness of the other occupant protection devices, such as airbags.

THE SUPPORT YOU NEED In certain rear-end collisions, the Front-seat Active Head Restraints found on the QX70 can move forward to help cushion the head to help assist in reducing whiplash-type injuries.

SELECTION

Hues that change in response to light and angle. Matching exterior and interior colours to reflect the distinctive energy and mood of the seasons. These are just two ways Infiniti designs colour to evoke feeling, express character and shape the emotional essence of a vehicle.

EXTERIOR COLOURS (CODE)



INTERIOR COLOURS (CODE)



WHEELS



20 INCH 5 DOUBLE-SPOKE ALLOY WHEELS



21 INCH 6 SPOKE LIGHT ALLOY WHEELS

All Infiniti QX70 models for UK are right-hand drive

INFINITI Europe, Division of Nissan International SA, CH-550-1047524-0, Z.A. La Pièce – Bât. B2, Route de l'Etraz, 1180 Rolle, Switzerland

This brochure is intended for general descriptive and informational purposes only. It is subject to change and does not constitute an offer, representation or warranty (express or implied) by INFINITI Europe. Before relying on this brochure to make a purchase decision, interested parties should directly contact the Infiniti Centre to confirm the accuracy of any information herein with regard to a specific vehicle. INFINITI Europe reserves the right to make changes, at any time, without prior notice, in prices, colours, materials, equipment, specifications, and models and to discontinue models or equipment. Due to continuous product development and other pre- and post-production factors, actual vehicle, materials and specifications may vary from this brochure. Some vehicles are shown with optional equipment. See the actual vehicle for complete accuracy. Availability and delivery times for particular models or equipment may vary. Specifications, options and accessories may differ in other countries. For additional information on availability, options or accessories, contact your Infiniti Centre.

¹ FCW is intended to warn you before a collision occurs; it cannot prevent a collision. Speed limitations apply. Always drive safely.

² Some Voice Recognition functions are limited depending on the language. Please contact your local Infiniti Centre for further details.

Infiniti has taken care to ensure that the colour swatches presented here are the closest possible representations of actual vehicle colours. Swatches may vary slightly due to the printing process and whether viewed in daylight, fluorescent or incandescent light. Please see the actual colours at your local Infiniti Centre.

Reproduction in whole or part of this brochure without the written permission of INFINITI Europe is forbidden.

GENUINE INFINITI ACCESSORIES

The same exacting standards applied to creating an Infiniti vehicle go into designing and manufacturing Genuine Infiniti Accessories. With a wide array of quality products designed to integrate seamlessly, you can be assured of a custom fit and finish.



ACCESSORIES SHOWN Crossbars, Infiniti branded roof box and 21-inch turbine dark silver alloy wheels.



ENTRY GUARDS Set in a stainless steel panel, these soft "Infiniti" illuminated entry guards give the sill area a sporty and sophisticated look. The kit, supplied in pairs, lights up your entrance and protects the paintwork.



20-INCH SILVER ALLOY WHEELS Wherever you go, there'll be no questions to your sense of style and love of sporty design. 265/50 R 20, 5 spoke alloy wheels.



SKI CARRIER These ski carriers make your QX70 the perfect holiday partner. Easy to mount and lock you can transport up to 6 pairs of skis. Available in smaller sizes as well.



TOW BAR Tested to meet the highest demands of safety and functionality, the tow bar allows you to bring your needs wherever you want. It is integrated into the car's bodywork and can be removed easily when not needed.



STAINLESS STEEL REAR BUMPER PROTECTOR While you load, unload and handle all your cargo, scuffs and scrapes can happen. This protector not only adds a sophisticated look, but it's durable enough to resist the wear and tear of everyday life.



TRUNKLINER Constructed of heavy, durable and flexible material, it helps keep your packages and other items from moving around while driving, while also protecting your cargo area from scratches and damage.

THE FORMULA FOR PARTNERSHIP

The excitement builds. The pressure mounts. Emotions surge. This is how partnership feels when technology, ingenuity and passion fulfil their promise. This is Infiniti Red Bull Racing and you.



Car shown is RB11/2015. Information and images correct at time of printing.



We may be the ones racing, but you are the winner. By combining our long-standing synergistic relationship with Infiniti Red Bull Racing and our Infiniti Performance Engineering Academy (<http://academy.infiniti.com/engineering/>), we can translate racing technology and driver exhilaration – from on-the-track to

on-the-road – with the speed and mastery of the pit crew. Giving you a vehicle which is more forward thinking, emotionally powered and ahead of the curve than any other automobile on the road today. This is the Infiniti formula for partnership; you can feel it every time you take the wheel.





Established in 1989, Infiniti has now grown to include saloons, coupés, convertibles, crossovers and SUVs in its line-up and spans 50 countries worldwide. Infiniti is unique and distinctive – not trying to be all things to all people, but everything to some people. At the heart of the Infiniti brand is a history of human attentiveness where the belief that the total ownership experience is much more important than just the car itself, coupled with a commitment to delivering a more empowering, more assured and more exhilarating driving and ownership experience.

Infiniti has come to be recognised as a brand that delivers expressive and striking car design. A distinctive design crafted by human hand and delivered with a powerful and daring presence on the road. This, combined with an obsessive attention to detail and precision engineering, all contribute to the feeling that to drive an Infiniti is something special.

FEATURES

	QX70 GT	QX70 GT Premium	QX70 S	QX70 S Premium
PERFORMANCE				
Speed sensitive power steering assistance	■	■	■	■
Rear Active Steering (RAS) (except on 3.7-litre V6 petrol)	-	-	■	■
Suspension with active Continuous Damping Control (CDC)	-	-	■	■
SAFETY AND SECURITY				
Opposed calliper brakes (front 4 pistons; rear 2 pistons)	■	■	■	■
Tyre Pressure Monitoring System (TPMS) (pressure display)	■	■	■	■
6 airbags (front driver and passenger airbags, front hip-thorax side airbags and front-to-rear curtain airbags)	■	■	■	■
Active front headrests	■	■	■	■
Rain sensor and light sensor	■	■	■	■
Auto dimming rear view mirror	■	■	■	■
Cruise Control	■	■	■	■
Speed limiter	■	■	■	■
Intelligent Cruise Control (ICC) with Low Speed Following (LSF)	-	■	-	■
Forward Collision Warning (FCW)	-	■	-	■
Intelligent Brake Assist (IBA)	-	■	-	■
Lane Departure Warning (LDW) and Lane Departure Prevention (LDP)	-	■	-	■
Anti-theft system	■	■	■	■
WHEELS				
Temporary spare wheel (replaces tyre repair kit, not available with 3.0-litre V6 diesel engine)	■	■	■	■
20" 5 double-spoke alloy wheels	■	■	-	-
21" 6 spoke light alloy wheels	-	-	■	■
EXTERIOR				
Body colour exterior mirrors	■	■	■	■
Tilt door mirrors while reversing	■	■	■	■
Heated, electrically folding exterior mirrors	■	■	■	■
Privacy glass for rear side and tailgate	■	■	■	■
Polished Aluminium roof rails	■	■	■	■
Dark chrome exterior air vent and sill strip	-	-	■	■
Red 'S' grade exterior badge	-	-	■	■
Smoked headlamps	-	-	■	■
Bi-Xenon lights with Adaptive Front-lighting System (AFS), auto-level and headlight washers	■	■	■	■
Front and rear fog lamps	■	■	■	■
LED rear lamps	■	■	■	■
Metallic paint	□	□	□	□
Scratch Shield paint	■	■	■	■
This paint is a soft clear coat that heals light scratches and swirl marks for long-lasting brilliance of the exterior colour.				

	QX70 GT	QX70 GT Premium	QX70 S	QX70 S Premium
TECHNOLOGY ON BOARD				
Full colour central display with Infiniti Controller	■	■	■	■
Rear view camera with front and rear parking sensors with display	■	-	■	-
Around View Monitor (AVM) with corner parking sensors, moving object detection and parking guidance	-	■	-	■
Multimedia pack	□	■	□	■
<ul style="list-style-type: none"> - High resolution touch screen central display with Infiniti Controller - 30 GB HDD Navigation system with RDS-TMC (Traffic Message Channel), Michelin guides and 3D POI content - 1 CD/DVD reader with MP3 WMA DivX compatibility and 10 GB Infiniti Music Box supported by Gracenote® music database - Voice recognition for navigation system* - Bose® Premium Sound System with 11 speakers 				
Bluetooth® technology for mobile connectivity and voice activation*	■	■	■	■
Bluetooth® audio streaming	■	■	■	■
I-Key with smart access, tailgate release and smart ignition	■	■	■	■
All-doors power windows with auto-closure linked to I-Key	■	■	■	■
COMFORT				
Sequential lighting system	■	■	■	■
Follow-me home lighting system	■	■	■	■
Analogue Infiniti clock	■	■	■	■
Dual zone adaptive climate control with auto-recirculation	■	■	■	■
Rear air conditioning vents	■	■	■	■
Illuminated vanity mirrors (driver, front passenger)	■	■	■	■
Electric glass sunroof	■	■	■	■
AUDIO				
7-speaker audio system	■	-	■	-
1 CD reader with MP3 WMA compatibility and 2 GB Infiniti Music Box	■	-	■	-
Multimedia pack	□	■	□	■
USB/iPod connectivity and AUX-in RCA	■	■	■	■

* Some Voice Recognition functions are limited depending on the language. Please contact your local Infiniti Centre for further details.

- Standard (no additional cost)
- Optional (at a cost)
- Not available

COLOURS & TRIMS

	QX70 GT	QX70 GT Premium	QX70 S	QX70 S Premium
INTERIOR				
Multifunction steering wheel	■	■	■	■
Leather steering wheel and gear shift lever	■	■	■	■
Power reach and rake adjustment for steering column	■	■	■	■
Aluminium pedals	■	■	■	■
Cello Flame Maple Wood	■	■	■	■
Black Lacquer and Aluminium interior trim (not available with Wheat upholstery)	□	□	□	□
SEATS				
Leather seat facings	■	■	■	■
10-way power driver's seat	■	■	-	-
14-way power driver's seat	-	-	■	■
8-way power front passenger seat	■	■	■	■
Front sports seats including power lateral thigh (driver only) and back-rest width adjustment (driver only), manual thigh extension	-	-	■	■
Driver's power lumbar support	■	■	■	■
Memory for driver's seat, steering wheel column and door mirrors (linked to I-Key)	■	■	■	■
Heated and ventilated driver and front passenger seats	■	■	■	■
2/3-1/3 folding rear seat back rest	■	■	■	■
Reclining rear seat back rest	■	■	■	■
ISOFIX seat mounting points in the rear seats	■	■	■	■
TRUNK AREA				
Power tailgate	■	■	■	■
Cargo cover with multi-partition net	■	■	■	■
First aid kit with warning triangle	■	■	■	■

VARIANT/ENGINE AVAILABILITY	QX70 3.0*	QX70 3.7	QX70 5.0
QX70 GT	✓	✓	
QX70 GT Premium	✓	✓	
QX70 S	✓	✓	
QX70 S Premium	✓	✓	✓

* EU: The QX70 3.0d is subject to availability from existing stock (availability is limited). The car can no longer be imported into the EU after 31/08/2015, and generally must be registered before 31/08/2015. Speak to your dealer for more information. **Switzerland:** The QX70 3.0d is subject to availability from existing stock (availability is limited). The car must be imported and registered before 31/08/2015. Speak to your dealer for more information.

			QX70 GT / QX70 GT Premium			QX70 S / QX70 S Premium		
			Leather			Leather		
Interior colours (code)			Graphite (G)	Java (P)	Wheat (C)	Graphite (G)	Java (P)	Wheat (C)
Exterior colours	Code	Type						
Black Obsidian	KH3	Solid	■	■	■	■	■	■
Malbec Black	GAC		□	□	□	□	□	□
Midnight Mocha	NAE		□	□	□	□	□	□
Iridium Blue	RAY		□	□	□	□	□	□
Graphite Shadow	KAD	Metallic	□	□	□	□	□	□
Umbria Twilight	JAA		□	□	□	□	□	□
Liquid Platinum	K23		□	□	□	□	□	□
Moonlight White	QAA		□	□	□	□	□	□
Interior trims								
Cello Flame Maple Wood			■	■	■	■	■	■
Black Lacquer and Aluminium			□	□	-	□	□	-

■ Standard (no additional cost)
 □ Optional (at a cost)
 - Not available

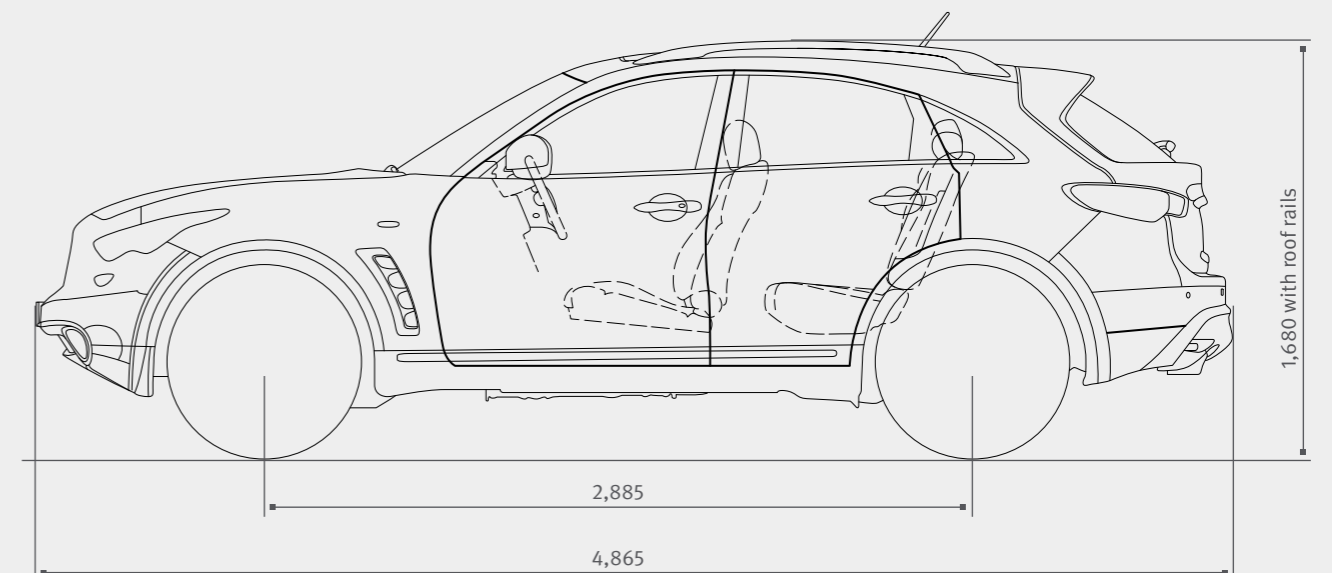
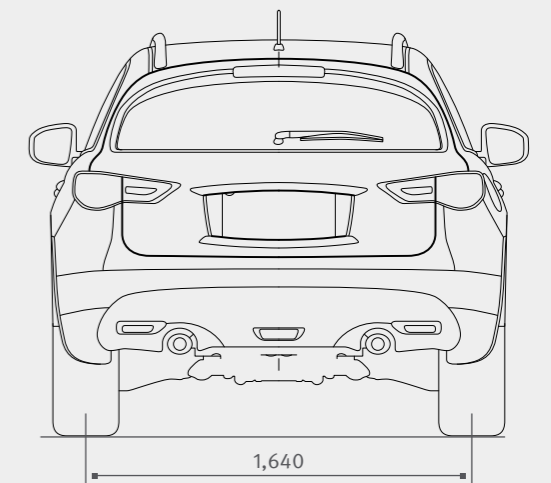
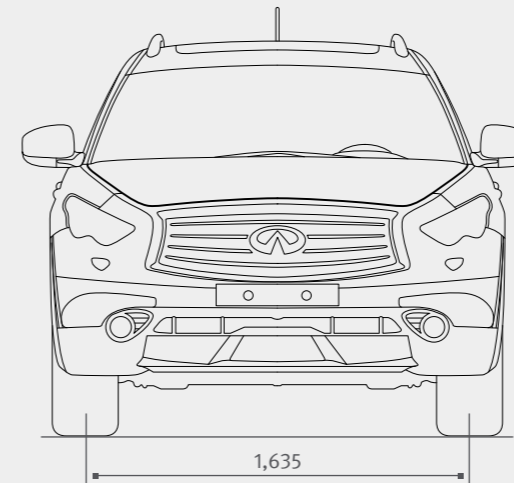

All dimensions are indicated in mm.

TECHNICAL SPECIFICATIONS

	QX70 3.0d [*]	QX70 3.7	QX70 5.0
ENGINE			
Fuel type	Diesel	Petrol	Petrol
Cylinders	V6	V6	V8
Displacement	2,993 cc	3,696 cc	5,026 cc
Power	175 kW (238 PS) at 3,750 rpm	235 kW (320 PS) at 7,000 rpm	287 kW (390 PS) at 6,500 rpm
Torque	550 Nm at 1,750 rpm	360 Nm at 5,200 rpm	500 Nm at 4,400 rpm
Transmission	Electronically controlled 7-speed automatic transmission with manual mode & magnesium paddle shifts. Driver-adaptive learning algorithm senses driving style and adjusts automatic shifting accordingly. Manual shift mode offers sequentially selected manual gearshifts	Electronically controlled 7-speed automatic transmission with manual mode & magnesium paddle shifts. Driver-adaptive learning algorithm senses driving style and adjusts automatic shifting accordingly. Manual shift mode offers sequentially selected manual gearshifts	Electronically controlled 7-speed automatic transmission with manual mode & magnesium paddle shifts. Driver-adaptive learning algorithm senses driving style and adjusts automatic shifting accordingly. Manual shift mode offers sequentially selected manual gearshifts
Driven wheels	Intelligent All-Wheel Drive (AWD)	Intelligent All-Wheel Drive (AWD)	Intelligent All-Wheel Drive (AWD)
Emissions	Euro 5 b+	Euro 6 b	Euro 6 b
PERFORMANCE			
Top speed	132 mph (212 km/h)	145 mph (233 km/h)	149 mph (240 km/h)
0–62 mph (0–100 km/h)	8.3 s	6.8 s	5.8 s
Estimated fuel consumption ¹			
urban	26.2 mpg (10.8 l/100 km)	16.2 mpg (16.8 l/100 km) ² / 16.8 mpg (17.4 l/100 km) ³	14.7 mpg (19.2 l/100 km)
extra-urban	38.7 mpg (7.3 l/100 km)	28.8 mpg (9.4 l/100 km) ² / 30 mpg (9.8 l/100 km) ³	27.7 mpg (10.2 l/100 km)
combined	32.8 mpg (8.6 l/100 km)	22.4 mpg (12.1 l/100 km) ² / 23.4 mpg (12.6 l/100 km) ³	20.9 mpg (13.5 l/100 km)
CO ₂ emissions ¹	225 g/km	282 g/km ² / 293 g/km ³	316 g/km
HANDLING			
Steering			
Type	Vehicle-speed-sensitive variable-assist power rack and pinion	Vehicle-speed-sensitive variable-assist power rack and pinion	Vehicle-speed-sensitive variable-assist power rack and pinion
Turning diameter	11.2 m	11.2 m	11.2 m
Suspension			
Front	Independent, double wishbone with coil springs over shock absorbers, stabiliser bar. S and S Premium: Continuous Damping Control (CDC)	Independent, double wishbone with coil springs over shock absorbers, stabiliser bar. S and S Premium: Continuous Damping Control (CDC)	Independent, double wishbone with coil springs over shock absorbers, stabiliser bar. Continuous Damping Control (CDC)
Rear	Independent, multi-link suspension, Dual Flow Path (DFP) shock absorbers, stabiliser bar. S and S Premium: Continuous Damping Control (CDC) and Rear Active Steering (RAS)	Independent, multi-link suspension, Dual Flow Path (DFP) shock absorbers, stabiliser bar. S and S Premium: Continuous Damping Control (CDC)	Independent, multi-link suspension, Dual Flow Path (DFP) shock absorbers, stabiliser bar. Continuous Damping Control (CDC) and Rear Active Steering (RAS)
Brakes			
Front/rear	355 mm front/350 mm rear ventilated discs with aluminium opposed front callipers (4-piston front, 2-piston rear)	355 mm front/350 mm rear ventilated discs with aluminium opposed front callipers (4-piston front, 2-piston rear)	355 mm front/350 mm rear ventilated discs with aluminium opposed front callipers (4-piston front, 2-piston rear)
CAPACITIES AND WEIGHTS			
Kerb weight	2,175 kg	2,012 kg	2,120 kg
Luggage volume	410 litres	410 litres	410 litres
Fuel capacity	90 litres	90 litres	90 litres
DIMENSIONS			
Exterior			
Coefficient of drag	0.36 x 2.71	0.35 x 2.71	0.35 x 2.71
Overall length	4,865 mm	4,865 mm	4,865 mm
Overall width with mirrors	2,134 mm	2,134 mm	2,134 mm
Overall height with roof rails	1,680 mm	1,680 mm	1,680 mm
Wheelbase	2,885 mm	2,885 mm	2,885 mm
Track width Front/Rear	1,635/1,640 mm	1,635/1,640 mm	1,635/1,640 mm

¹ The values stated were determined under test conditions according to the measuring methods specified in the most recently amended version of European Directive 715/2007/EC and may not represent the actual results achieved in real world driving conditions. In addition to the fuel efficiency of a car, driving behaviour as well as other non-technical factors play a role in determining a car's fuel consumption and CO₂ emissions.

² With 20" 5 double-spoke alloy wheels

³ With 21" 6 spoke light alloy wheels / 21-inch exclusive anthracite alloy turbine wheels with diamond cut finish

^{*} EU: The QX70 3.0d is subject to availability from existing stock (availability is limited). The car can no longer be imported into the EU after 31/08/2015, and generally must be registered before 31/08/2015. Speak to your dealer for more information. **Switzerland:** The QX70 3.0d is subject to availability from existing stock (availability is limited). The car must be imported and registered before 31/08/2015. Speak to your dealer for more information.



Visit us online to create your ideal Infiniti, get pricing and more.

www.infiniti.eu

QX70

CONNECT Join our community, and get the latest on Infiniti.

f [Facebook.com/InfinitiEurope](https://www.facebook.com/InfinitiEurope) **t** [Twitter.com/InfinitiEurope](https://www.twitter.com/InfinitiEurope)