



New Personal Coupe

PRELUDE

HONDA®



**An Intelligent And Glamorous Profile
That Many Will Find Irresistible.**







**A Long Nose With Honeycomb Grill,
A Wide And Low Body. And A Sunroof
To Top Everything Off!**





**Note The Short Deck,
Wrap-Around Bumpers – The Image
Of Strength Tempered With Dignity.**





**A Calm, Color-Coordinated Interior, Relaxing
It's Plain To See How Much Comfort The Prel**



Seats ...
ude Has To Offer.



**Highly Functional Instrumentation Featuring
Innovation. It's A Sign Of The Prelude's Preci**



Typical Honda
sion.

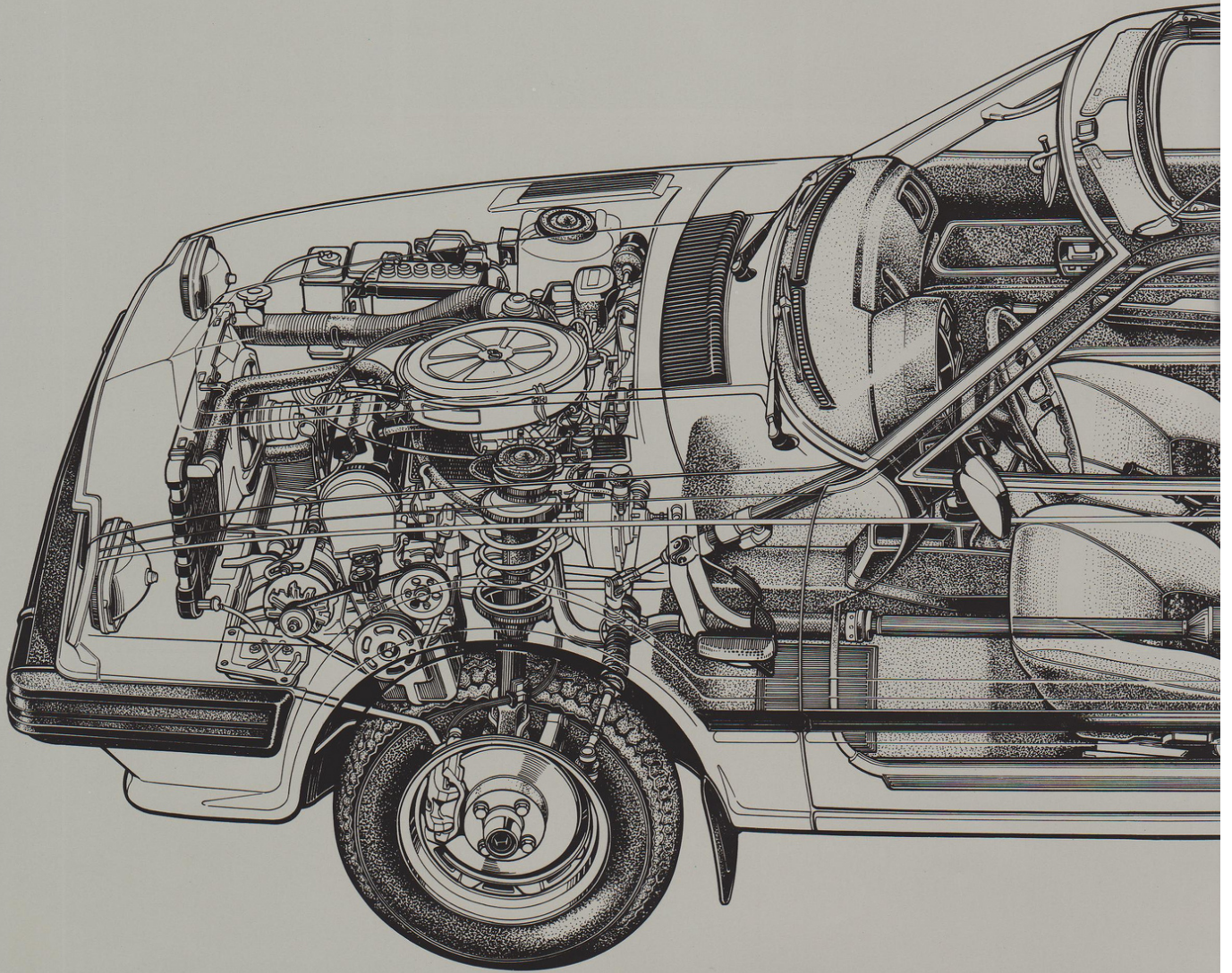

Honda's "Balanced" Ap It's What Makes The Prel



Honeycomb grill

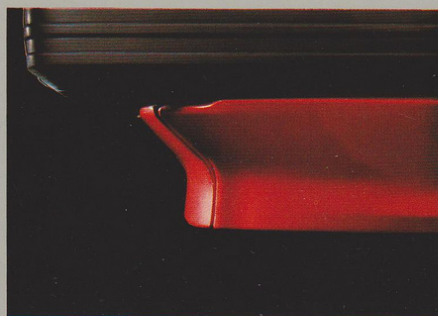

Air-dam skirt



Protective rubber bumper cover

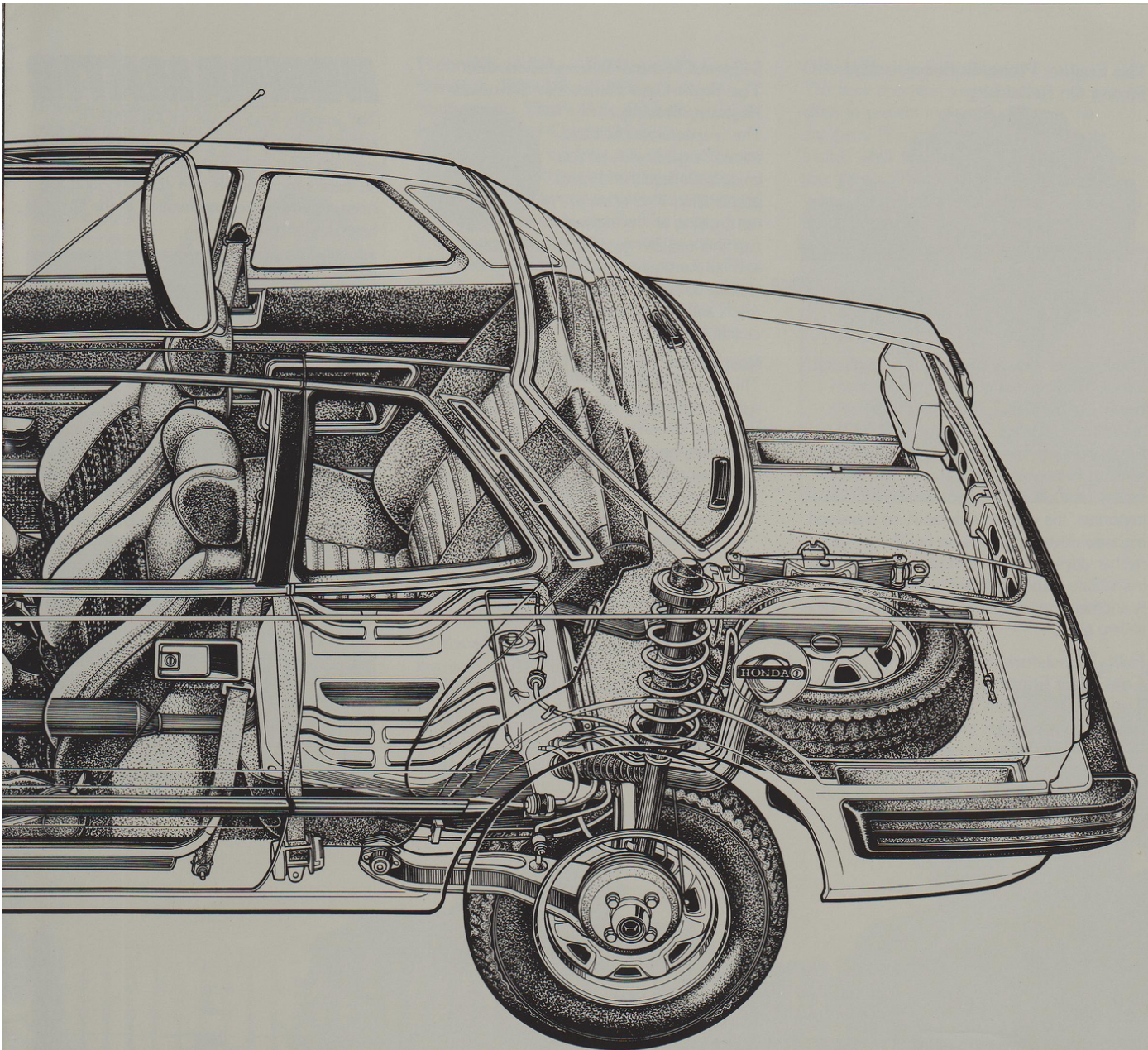

**Approach To Engineering.
Appears Sensible Yet Exciting.**



Rectangular headlight and snow drain

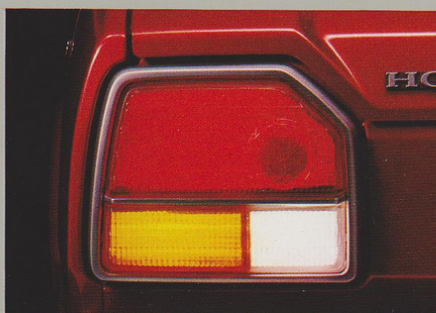

Rear light cluster



Side protection moulding

The Engine: Plenty In Reserve And Strong On Reliability.

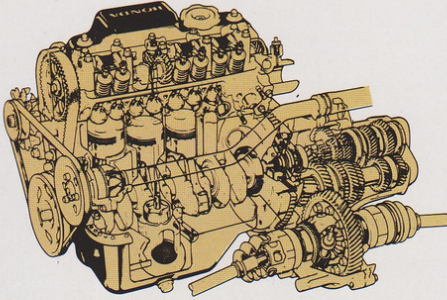

The Prelude's power package is a tough, flat torque 1602cc engine having a maximum power of 80 PS at 5,300 r.p.m. (DIN) and maximum torque of 12.9kg/m at 3,500 r.p.m. (DIN). It delivers steady power to assure smooth running throughout the low and high speed ranges, and offers great acceleration. Equally important, the engine is durable, so sustained highway driving presents no problems—and neither does stop-and-start city driving. Immediate response to accelerator movement is another appreciable feature. And the engine is very quiet.

Fully Transistorized Ignition For Consistent Starting, Stable Performance.

Thanks to this system, the Prelude is a consistent first-time starter, and it maintains accurate ignition timing for a long period. Because there are no points, there's naturally no need for point gap adjusting, point changing and other conventional maintenance tasks.

5-Speed Manual Transmission: Just The Right Gear Ratios For City And Highway Driving.

The 5-speed manual transmission's gear ratios let you enjoy both sedate and rapid acceleration. And when you're out cruising on the highway you can shift into 5th gear for greater economy and an even quieter ride. Smooth gear shifting is assured by the unique synchromesh and hydraulic diaphragm clutch.



Responsive Rack And Pinion Steering.

This type of steering matches the suspension system perfectly to provide excellent handling. Rack and pinion steering is very responsive, and helps the driver maintain his control over the car.

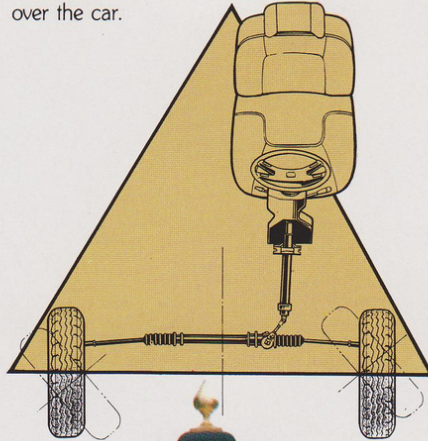

HONDAMATIC

The smooth, time-proven HONDAMATIC automatic transmission is now even better than ever. An **OD** overdrive range has been added, so there's more power and comfort—and less noise. What's more, acceleration in the **+** range has been improved.



Target Meter Transmission Mode Indicator

For greater convenience, an automatic transmission mode display has been incorporated into the centralized target meter. So there's no need to look down to ensure that you've selected the correct position.

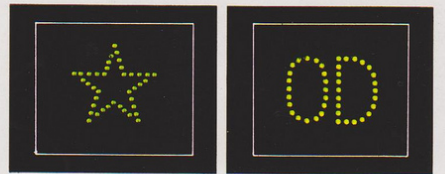

**The Engine-Suspension Combination
It Assures Responsive**



Smooth, Responsive Brake System.

The Prelude's new servo-assisted brake system provides a swift and dependable yet soft response to light pressure on the brake pedal. A diagonal dual circuit system is employed, so if one circuit should fail the other will continue to provide stopping power. Both the new front discs, which have calipers designed to resist salt and muddy water, and the rear drums adjust themselves automatically.

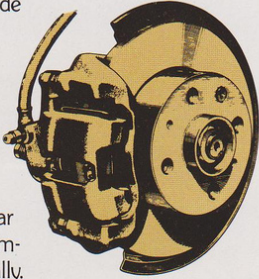

Steel Belted Radial Tires Are Standard.

The Prelude comes complete with 155SR-13 steel belted radial tires, which offer outstanding performance and durability.



Front Wheel Drive, Rack And Pinion Steering, Four-Wheel Independent Suspension. That's Why Prelude Is A Road-And-Corner Hugger.

Take the Prelude out for a run and you'll soon see just how good it is at holding the road. You'll also feel how comfortable the ride is and how easy the car is to handle. The sporty four-wheel independent suspension incorporating MacPherson struts and front and rear stabilizers is a major factor in the Prelude's outstanding performance. Other contributors are the front wheel drive system, which improves traction and makes steering easier, and the highly responsive rack and pinion steering.

Damper Characteristics Help The Prelude Grip The Road.

The highly accurate damper setting affords even greater comfort. You get a firm feeling of the road, and road holding is dependable at high speed. In fact, the overall suspension performance is so good it may cause you to think that your driving has improved!

Rear Suspension Provided With Optimum Compliance.

Radius arms and lower arms incorporated in the rear suspension have optimum compliance. Therefore, unpleasant bumps caused by poor road section joints and other road surface faults are smoothed out considerably.

Offset Spring Suspension.

The front and rear suspension springs are offset to prevent excessive stress on the dampers. This results in reduced damper friction while the car is running, which means you get a more comfortable ride. Driveability is improved by the front and rear stabilizers, which reduce body roll during cornering.

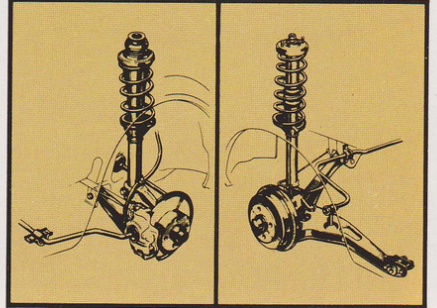

Provides A Quiet, Comfortable Ride.
Handling, Too.





The Sunroof And The They're Two Of The Big Features



Electric Smoked-Glass Sunroof Adds To Driving Fun!

Open the sunroof and go for a drive on a clear, early morning...or sunny afternoon... or on a star-lit night. That's when you'll experience an exhilarating feeling of spaciousness, of freedom. It's a pleasurable feeling, too, to drive with the smoked-glass sunroof closed and the inner sunshade open.

The car body has extra strength and rigidity to compensate for the sunroof, which is 521mm long and 905mm wide. The electrically powered sunroof opens smoothly when you press the dash-mounted control button, and it will stop wherever you want it to when you release the button.



Deflector Prevents Wind Problems.

Even at high speed you can have the sunroof fully open and not worry about wind noise and ruffled hair styles. That's because a deflector automatically moves up into position whenever the sunroof is opened.

Three ways to enjoy the electric sunroof/manual sunshade combination:

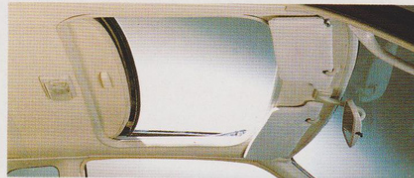

Open both the sunroof and sunshade to let in light and air.

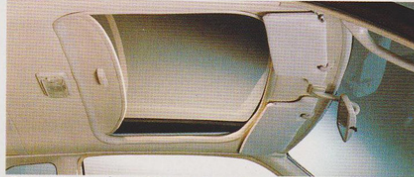

Close the sunroof but leave the sunshade open, so the car interior is bright and quiet.



Close both the sunroof and sunshade to turn the Prelude into a conventional car.



Highly Functional And Safety-Oriented Instrumentation And Controls.

The comprehensive instrumentation and control systems are positioned so that they are easy to see and use. And, to minimize the driver's eye movement, the instruments are located in order of priority so that the most important ones stand out clearest of all. You get such a lot of information from the various meters and indicators that you have a good idea of the car's condition at all times.

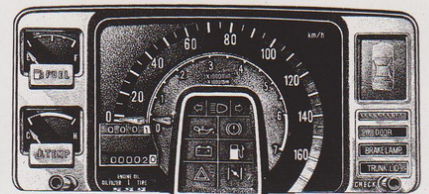

Unique Centralized Target Meter.

Since the speedometer is the instrument you have to monitor most often, the Prelude has a large, clear, easy-to-read one. Right in the center, on the same axis, is the tachometer, so speed-wise you know at a glance how the car and engine are performing. To help you further, the speedometer's dial is black while the tachometer's is grey, and illumination of the speedometer is brighter. To the left of the target meter are the fuel and water temperature gauges.



Instrument Panel. That Make The Prelude A Great Car.

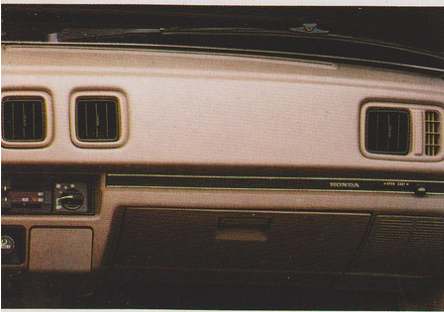

Safety Indicators Tell You In Words And Pictures If Something Is Amiss.

If you don't properly close one of the doors or the trunk lid, the Prelude's safety indicators will tell you. They'll also inform you if one or both of the brake light bulbs has burnt out. The indicators are dual types: a diagram of the car lights up to indicate the malfunction simultaneously with an illuminated printed warning.

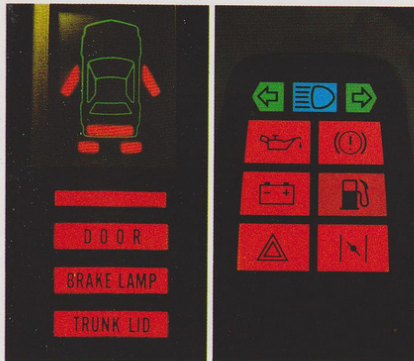

Maintenance Indicators Give You Automatic Reminders.

The Prelude really does make things easier for you. These maintenance indicators tell you when to change the oil and oil filter and to rotate the tires. The indicators change color according to the mileage done: a green indicator means everything is normal, a yellow one is a warning signal, and a red indicator means you should take action immediately.

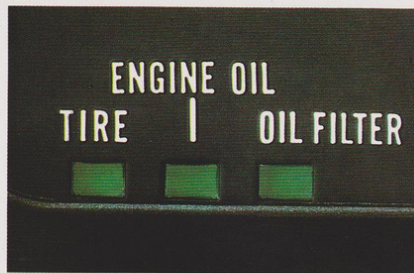

Conveniently Located Controls.

All the controls are positioned so that to operate them the driver does not have to take his hands off the wheel for more than a moment. The light controls are located on one steering column stalk and the wiper/washer controls on another.

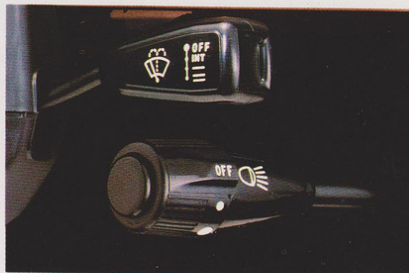

Electronic Digital Quartz Clock.

The highly accurate clock has a bright display so that it is easy to see. The display comes on when the ignition is switched on; when the ignition is off the time is displayed if the cover of the time-adjusting buttons is pressed. These buttons make time resetting simple.



New Rotary-Dial Radio.

The radio has been designed from the viewpoints of audio performance and driver convenience. Simple to operate, it's located so that the driver doesn't have to lean forward to operate it. Preset stations don't drift, rotary tuning in to other stations is smooth, and sensitivity is high.



Tasteful Color Schemes, A Refined Atmosphere.

The entire interior is tastefully designed to give you not only physical but also visual comfort. There's the deep-pile, wall-to-wall carpet. The attractive roof lining. The quality materials and excellent finishing of the upholstery. And the overall color scheme is based on one of three colors to match the body color: glamorous soft red, lustrous black or classical soft ivory. Each of these colors is very easy on the eyes, restful. Very contemporary, too.

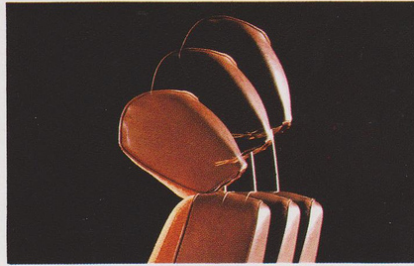
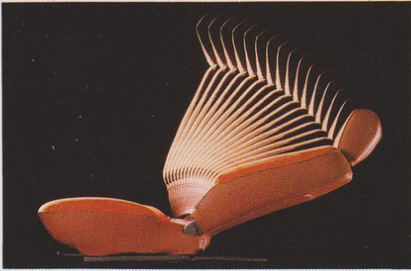

Headrests Adjustable In Four Directions!

The front headrests can be moved up and down to one of three positions, and can also be adjusted up to 48 degrees in the forward-backward direction. With so many combinations available, you're bound to find the one that is just right for you.



Body-Hugging Front Buckets.

You get a feeling of luxury and contentment when you sit in one of the front seats. It's like sinking into one of your very favorite chairs. Such a nice fit. The shoulder section is indented to give your shoulders freedom of movement; the waist section is filled out to provide better support and improved holding. Many human-engineering considerations are integrated in the seat design to facilitate the driver's movements and reduce his fatigue. A long drive will prove to you how worthwhile these efforts have been.

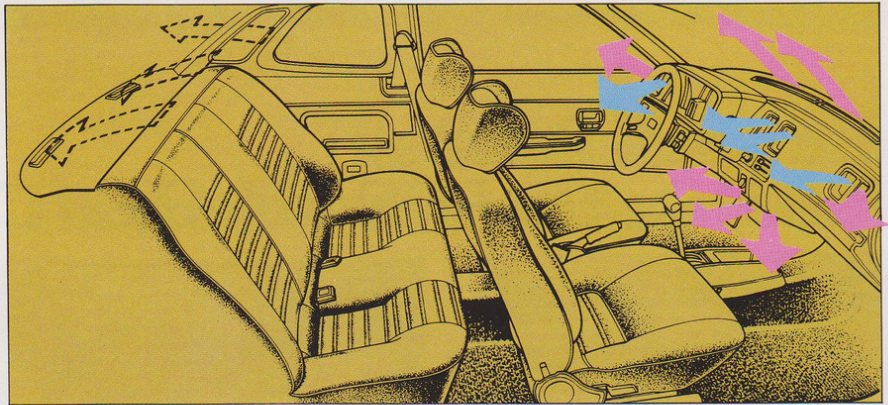

Good Ventilation Keeps You Alert.

You can use the Prelude's flow-through fresh air ventilation or forced air ventilation system with its 3-speed blower to enable you to enjoy every minute of your driving. For the sake of safety, the control levers move horizontally.

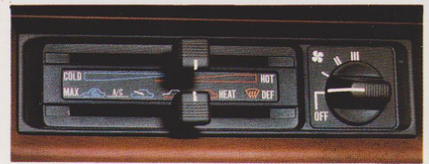

Optional Built-In Air Conditioner Saves Room.

Because the optional air conditioner is built into the instrument panel, there's no bulky unit to deprive the front passenger of legroom. The air conditioner functions with the air-mix heater to assure a comfortable temperature throughout the year.

The Stylish Interior ... It Turns Everyday Driving Dullness Into A New, Refreshing Experience.



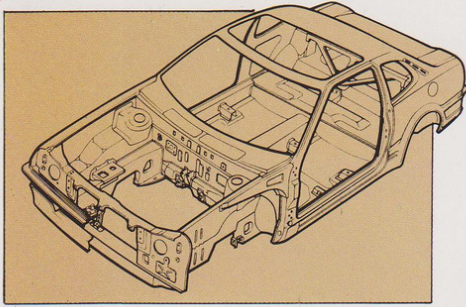

To Keep Things Quiet Inside Prelude, Most Noise Is Kept Outside.

When the Prelude is on the highway, conversations can still be held naturally thanks to thorough noise and vibration suppression. For instance, the crankshaft has eight counterweights to ensure smooth running of the engine. Then there's the new engine mounting method that reduces vibrations. The large silencer with prechamber and flexible exhaust pipe. The highly effective bulkhead insulation. The sound-deadening wall-to-wall carpeting. The full doors, which are designed to reduce wind noise. And yet another wind-noise reducer: the bonded windshield.

Safety: Always A Honda Priority.

The Prelude has some safety features that are designed to prevent accidents as well as others that are intended to minimize damage should an accident occur. Standard safety features include the unique monocoque body, which is tough and solid on the one hand, yet absorbs impacts on the other. The three-point anchored ELR seat belts up front. The electric rear window demister. The side window demisters. The dual windshield washer nozzles. The side view mirror with its flexible mounting. And the anti-dazzle day/night rearview mirror.



ELR 3-point seat belts (front)

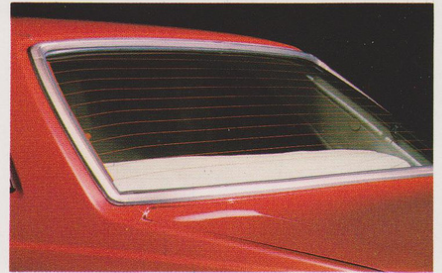

Electric rear window demister



Door window demister



Dual windshield washer nozzles



Flexible side view mirror mounting

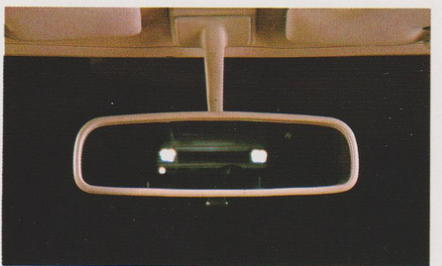

Day/night breakaway mirror





Technical Specifications

Horsepower (DIN)	80 PS/5,300 rpm, 59 kW/5,300 min ⁻¹		
Torque (DIN)	12.9 kg·m/3,500 rpm 126.5 N.m./3,500 min ⁻¹		
Engine	Water-cooled 4-stroke OHC in-line 4-cylinder transversely mounted		
Displacement	1,602 cm ³		
Bore & Stroke	77 × 86 mm		
Compression Ratio	8.4:1		
Transmission	Manual	5-speed synchromesh	
	Hondamatic	Torque converter with three manually selected forward speeds	
Gear Ratios	Manual	Hondamatic	
	1st	3.181	L 2.047
	2nd	1.842	
	3rd	1.200	☆ 1.370
	4th	0.896	OD 0.969
	5th	0.718	
	Reverse	3.000	R 1.954
Clutch	Dry single plate, diaphragm spring		
Steering System	Rack and pinion, collapsible steering column, locking type, 3.26 steering wheel turns lock-to-lock		
Drive Wheels	Front		
Suspension	4-wheel independent with MacPherson struts and front and rear stabilizers		
Brakes	Front	Hydraulic servo-assisted discs	
	Rear	Hydraulic servo-assisted leading/trailing shoe drum type with PCV (pressure control valve)	
Tires	155SR-13		
Dimensions	L×W×H	4,090 × 1,635 × 1,295 mm	
Wheelbase		2,320 mm	
Tread	Front	1,400 mm	
	Rear	1,410 mm	
Ground Clearance		170 mm	
Fuel Tank Capacity		50 liters	
Curb Weight		920 kg (manual transmission)	

Standard Equipment

Exterior	Electric glass sunroof with sliding sunshade and wind deflector	
	Door mirrors (both sides)	
	Side protection mouldings	
	Protective rubber bumper covers	
	Mudguards (front)	
	Inner fenders (front)	
	Interior	Fully reclining bucket seats with adjustable headrests (front)
		3-point seat belts with Emergency Lock Retractor (front)
		Day/night rearview mirror
		Sun visors, vanity mirror on passenger's side
Collapsible steering column with lock		
Centralized target meter		
● Speedometer (odometer/tripmeter) / Tachometer		
● Fuel gauge / Water temperature gauge		
● Pilot lamps (choke/brake/oil pressure/oil level/battery charge/ high beam/fuel/hazard lights)		
● Safety indicators (doors/trunk lid/brake lamps)		
● Maintenance indicators (tire rotation/engine oil change/oil filter change)		
Door window demisters		
Hand grip (front passenger side)		
Rear side pockets		
Carpet (wall-to-wall)		
Remote trunk lid release		
Passing lights		
Lights	Instrument illumination control	
	Hazard warning lights	
	Glove box light	
	Interior light	
	Trunk room light	
	Halogen headlights	
Electrical system	2-speed wipers with intermittent wipe	
	Electric windshield washer	
	Electric rear window demister	
	Radio (AM/FM)	
	Electronic digital clock	
	Heater/Illuminated heater control panel	
	Some of the above equipment may not be available in certain countries.	

Body & Upholstery Colors

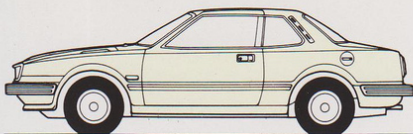

Shetland White

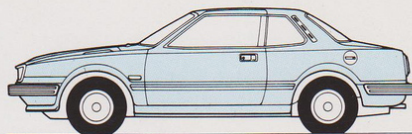
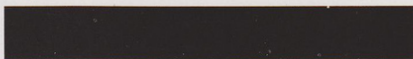

St. Moritz Silver Metallic

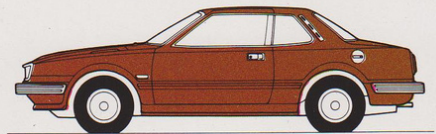
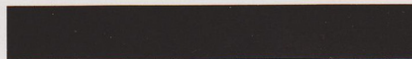

Tudor Red Metallic

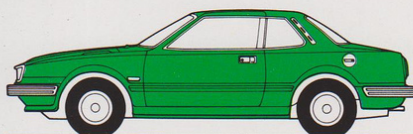

Stuart Green Metallic

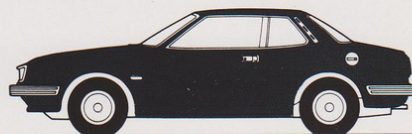
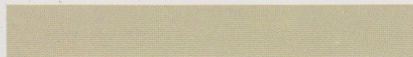

Inverness Blue Black Metallic



Shades of colors printed here may differ slightly from those of the actual automobile. Some of the colors may not be available in certain countries.

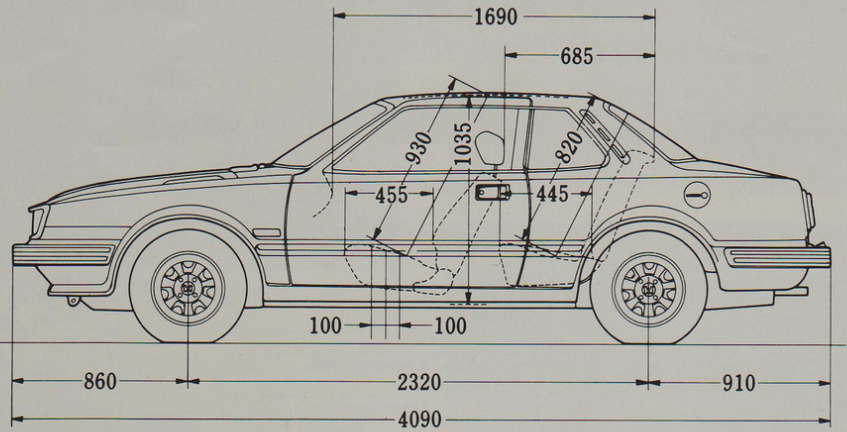
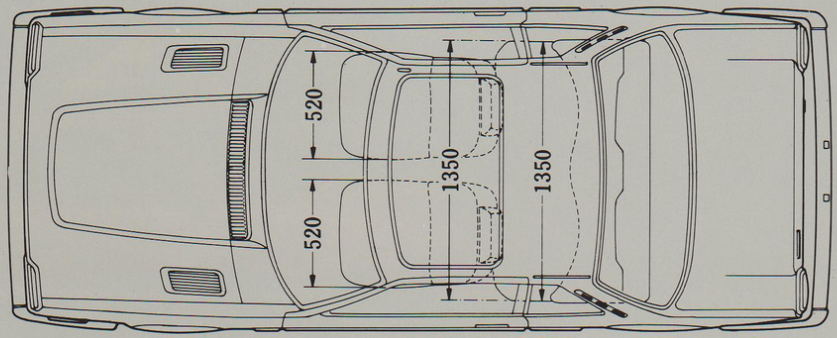

PRELUDE

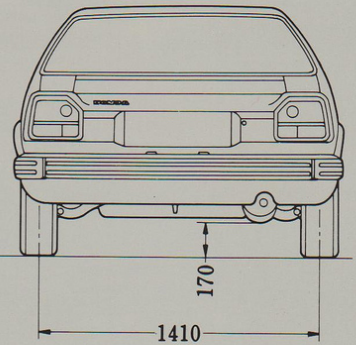
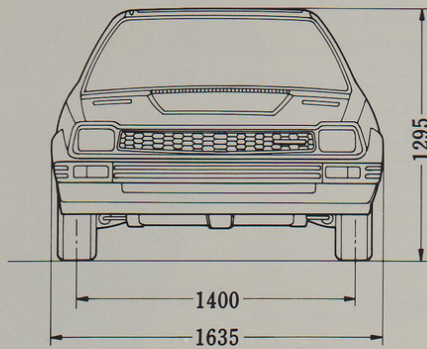

Unit: mm

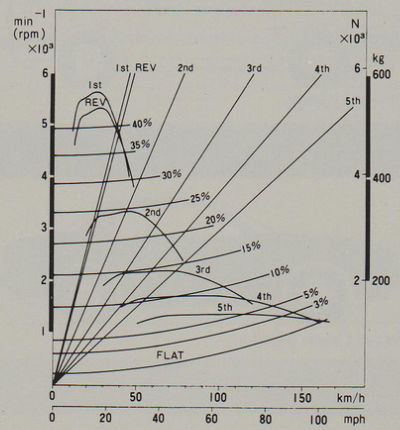
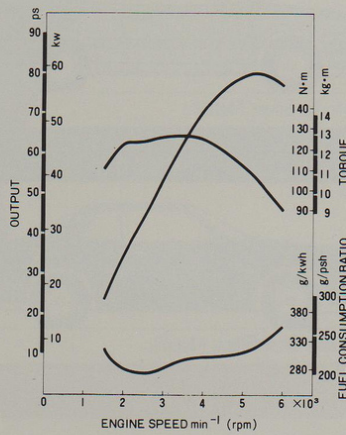

NEW PERSONAL COUPE

Honda Brings You

PRELUDE

Honda's new Prelude...featuring a magnificent, classical body contour, a luxurious and tastefully colored interior, and an electrically powered smoked-glass sun-roof that opens really wide. The Prelude's beautiful lines perfectly complement the smooth, high-performance engine and sports car-like suspension—and add something



extra to the pleasure of driving this new breed of car.

In terms of overall driving comfort, performance and pride of ownership, the Prelude is bound to please the most demanding driver, especially the individualist.

That's why we call it the Personal Coupe...a stylish car for stylish people who love to be independent.

Honda-0132



Honda Motor Co., Ltd. reserves the right to change or modify equipment or specifications at any time without prior notice. Details, colors, descriptions and illustrations are for information purposes only. As specifications or equipment may vary in some countries, please check with your nearby Honda dealer. **HONDA**[®]
HONDA MOTOR CO., LTD. TOKYO, JAPAN