



The Honda Price Promise

One sharp, fair price for everyone and better resale values. That's our promise to protect the value of your investment in a new Honda.

Special deals, demonstrator sales and fleet discounts all work to lower resale prices, undermining the value of your new car and speeding up its depreciation. So at Honda New Zealand, we've traded in the old sales model for a new one that is easier, fairer and offers our customers better value.

You don't have to negotiate to get a fair deal on a new Honda. Our Price Promise gives every buyer the same sharp price right from the start and we promise to keep our prices as reliable and consistent as we possibly can. And that means your new Honda will hold its value better than most other brands.

So when you choose a new Honda, you'll drive away with a great car and lasting value. We promise.

How to contact us

Tel: 0800 255 666
Fax: 0-9-262 3247
Email: hondacare@honda.co.nz
Website: www.honda.co.nz
Honda New Zealand Limited
105 Wiri Station Road
PO Box 97-340
South Auckland Mail Centre

Specifications and features listed are accurate at the time of printing (August 2004). Honda New Zealand Limited reserves the right to change specifications at any time without prior notice. Some vehicles may be shown with optional equipment and illustrated examples may differ slightly from New Zealand specification. Paint and trim colours shown may differ from actual colours due to limitations of the printing process.

August 2004 (2004 YM). Part No. 09008-SFE-04

© Honda New Zealand Limited.

Honda New Zealand is committed to planting 10 native trees for every new Honda sold through the Honda TreeFund. Over 60,000 native trees are expected to be planted every year, as a measurable way of absorbing some of the emissions produced by motor vehicles. See www.honda.co.nz/environment

Printed on Environmentally Responsible Novatech which has EMAS, ISO14001, and FSC certifications and is ECF.

HONDA
The Power of Dreams



Odyssey



Odyssey



VTIL

THE ALL NEW ODYSSEY

Throughout life's journey it's important to continuously adapt and evolve. By challenging convention we can create new and better solutions. That's the Power of Dreams.

At Honda, this thinking has borne the third generation Odyssey – an exciting new vehicle that blurs the line between seven-seater and wagon.

The Odyssey will elevate your expectations. Built on an ultra-low platform, its sleek and flowing form is both sporty and elegant. Inside there's more space, flexibility, and comfort than ever before, while the lower centre of gravity produces performance and handling in a class of its own.

The car you've always needed, has become the car you really want.





A NEW LEVEL OF STYLE

VTIL

Taking the Black Panther as a design cue, the sleek aggressive form is beautifully aerodynamic. Poised and elegant, the Odyssey leads the field in style and design.

Once again, Honda innovation has led to mould-breaking design. An ingenious ultra low-floor platform has lowered the profile, producing the most stylish and spacious Odyssey ever. This is the result of the clever layout of the fuel tank, rear suspension and exhaust system. You don't have to compromise on style to get the versatility you need.

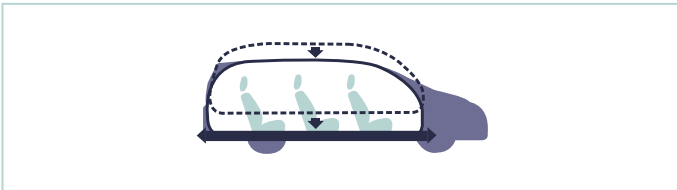

The chrome-plated floating grille, slim-profile headlights and front bumper create a bold look. The stance is flared low and wide to emphasize the Odyssey's breadth and strength, while the side profile features an elegant, smooth silhouette. The Odyssey is a car you'll be proud to own and happy to be seen in.



Inside, an ergonomically refined, 3-D dash design complements the Odyssey's exterior styling. The wrap-around dash creates a welcoming, cockpit-style environment for the driver, bringing all the controls within easy reach. The instrument display features blue translucent illumination. The effect is simply stunning and easy to read. Real time and average fuel consumption meters let you keep an eye on how much, or little, petrol you're using.



A centre console table has a lidded compartment and cup-holders, with a dimpled surface to keep things from sliding around. The console has power and auxiliary sockets for individual entertainment choices. It folds away to make extra space and allow walk-through from the front seats to the back.



For complete comfort the Odyssey is fully air-conditioned. The system is incredibly quiet, with individual vents in all three rows and controls front and middle.



The 6-speaker CD system and Cruise Control can be operated by buttons on the steering wheel - so you're free to focus solely and safely on the road ahead.



Woodgrain and titanium-look panelling from the dashboard to the doors gives a unified, luxurious feel to the interior, adding a sense of prestige. You'll find sunglasses holders, eight cup-holders, map lights, and plenty of storage for maps, magazines and other items.





A NEW LEVEL OF FLEXIBILITY AND COMFORT

VTIL

As our lifestyles become more dynamic, we need vehicles that will keep up. The Odyssey's revolutionary design offers more space and versatility than ever before. You can comfortably seat between one and seven people, and have the freedom to carry loads of all shapes and sizes. Whether you're taking a trip, or just going for a cruise, the Odyssey is all the cars you'll ever need.

Our latest 7, 6, 5, 4, 3, 2 and 1 seater has a huge range of seating and cargo variations. The Odyssey's interior can be quickly transformed from a seven-seat cabin to a massive luggage area. The low, flat luggage space has no intrusions for extra space and ease of loading. When all rear seats are folded down there is a remarkable 1056 litre capacity.



Comfort abounds wherever you go in the Odyssey. Multi-adjustable front seats with supportive cushioning are designed for better lower back and hip support. This will help keep you comfortable on longer journeys. The second row seats have a 60:40 split while the third row has a 50:50 split for extra versatility and stowing options. There are two-stage heated front seats in Odyssey L models.



The second-row seats slide 320mm making it easier to get into the third row. They also have an easy double fold-down mechanism, allowing them to be stowed flush.

Operation sequence for stowing row two:

- 1 Lift up the front edge of the seat cushion and then push it from the back edge forward to sit flush behind the front seatbacks.
- 2 Collapse the headrest by pushing forward from the back.
- 3 Collapse the second row seat-back forward with the lower lever.



The third row seats fold neatly into the floor, opening up a wagon-style cargo space. In the Odyssey VTIL and VTIL-S these seats fold away electronically. (Some interior colours are unavailable)





A NEW LEVEL OF PERFORMANCE AND HANDLING

VTIL

By lowering the centre of gravity, we've raised the level of performance and handling. With luxury car standards of ride comfort, and a drive that's much more like a sports-sedan, the latest Odyssey breaks the mould at every turn, and down every straight.

The Odyssey has a lithe and responsive chassis, proving a smooth ride and sporty handling are not mutually exclusive. It also has one of the worlds most advanced suspension systems. A double-wishbone layout at the front ensures exemplary straight-line stability and smoothness. The compact rear suspension is a reactive-link double wishbone system - which plays a big part in achieving the low floor platform.

The new Odyssey is based on the global Accord platform, and is powered by a version of the award winning New Zealand Car of the Year, the Accord Euro's advanced 2.4 litre i-VTEC engine. This powerplant is renowned for its all-round excellence in the sporty mid-sized sedan and for the Odyssey it has been optimised for power and torque characteristics more suited to a load-carrying vehicle. In Odyssey guise the engine produces 118kW at 5500rpm, with 218 Nm of torque at 4500rpm.

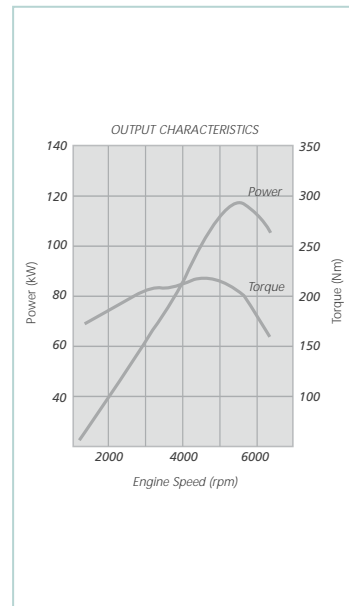
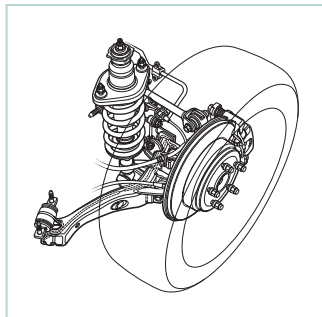
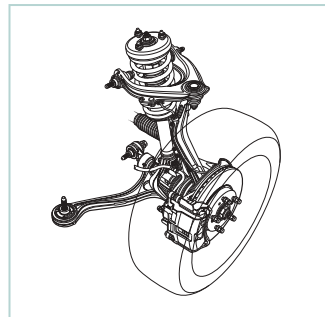

i-VTEC DOHC

The i stands for intelligent because this is a thinking engine. Synchronising Honda's VTEC and VTC systems, the Odyssey's i-VTEC engine reads your driving style to deliver spirited performance, outstanding fuel economy and reduced exhaust emissions.

VTEC (Variable Valve Timing and Electronic Lift Control) adjusts the lift and opening duration of the valves to produce low-rpm torque and high rpm power. At low-rpm, VTEC adjusts valve timing and lift for optimum fuel efficiency. The timing of the intake valves is staggered and their lift asymmetric - creating a swirl effect within the combustion chamber. The result is increased burn speed and improved combustion stability. As engine rpm changes, VTEC shifts to a dual-valve, high-lift, long-duration cam profile for improved high-rpm engine output.

VTC (Variable Timing Control) continuously adjusts camshaft phasing across the power band. As engine rpm changes, the VTC system monitors cam position, ignition timing, exhaust emissions and throttle position and advances or retards the intake cam throughout a 50 degree range, optimising engine output and reducing emissions.



A 5-speed automatic transmission with SportShift delivers you seamless, perfectly timed shifts and outstanding fuel economy. Select SportShift mode and take control, by shifting up and down gears at the flick of a lever, you'll optimise the Odyssey's sporty characteristics.

Grade Logic Control ensures even smoother gear selection and acceleration by detecting whether you're driving uphill or down, and adjusting the shift patterns to suit.

Honda's linear Variable Gear Ratio (VGR) steering contributes to the smooth, responsive handling. VGR senses the amount of steering torque generated as the wheel is turned. This provides precise, predictable control on the highway and extra assistance at low speeds.

Transmission Lock-Up Control

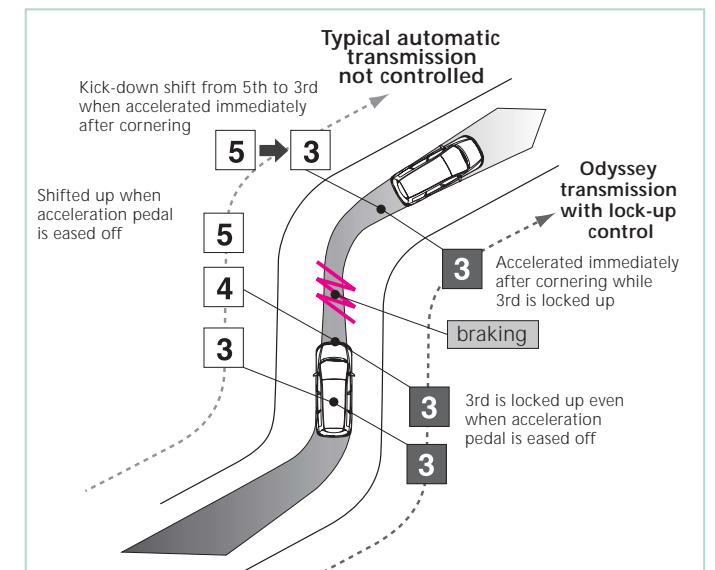

The Odyssey has an impressive turning radius of only 5.4m. This is equal to the Accord Euro sedan.





A NEW LEVEL OF SAFETY AND CARE

At Honda we design cars to protect people from every possible angle. We also design cars to protect our environment.

The Odyssey can accurately detect the level of G-Force impact and will react accordingly. Dual-stage front i-SRS airbags and SRS side airbags provide all-round protection. All three rows are equipped with a side curtain airbag system to protect the head and neck of occupants during a side collision. In total you'll be protected by ten airbag positions.



G-CON

Honda's unique G-CON technology is built into the very core of the Odyssey. The passenger compartment shields and protects you with a ring of high tensile steel, side intrusion beams, and passenger safety zones. This absorbs the energy of a collision and deflects impact forces away from the passenger cell.

Honda is a leader in the area of pedestrian safety technology. The Odyssey boasts impact absorbing materials and body-structures to also reduce the risk of injury to pedestrians.

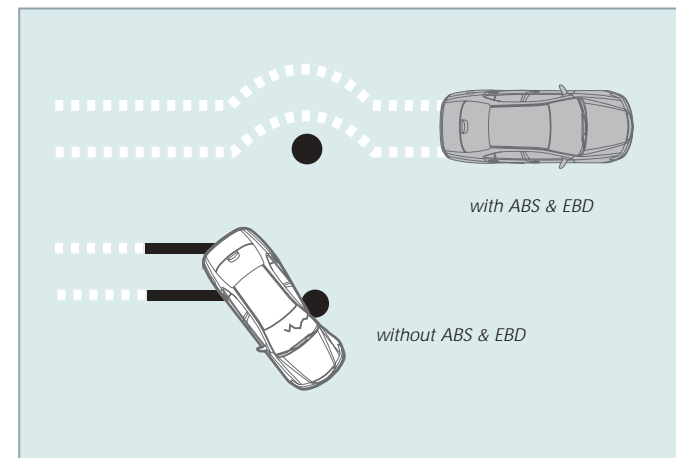

Anti-Lock Braking System

Computer controlled ABS prevents the wheels from locking and allows you to retain steering control while braking hard or on slippery surfaces. With ABS you can steer around potential accidents, which could otherwise occur with locked wheels.

Electronic Brake Distribution (EBD)

EBD maximises the distribution of braking force between the front and rear wheels, depending on the passenger and cargo positions.

Emergency Brake Assist

If you ever have to brake hard in an emergency, the Odyssey is ready to lend a hand. Sensors detect sudden pedal action, automatically boosting your braking power to reduce stopping distance.

Parking Sensors

To avoid any small bumps or scrapes, front and rear parking sensors are standard.



Security also means keeping your car safe when you're away from it. So every Odyssey has central door locking activated remotely from your key, an alarm and an engine immobiliser.



For the safety of young passengers, there are child seat anchor points and tethers for all five rear seats.



LEV

As a Low Emission Vehicle, the Odyssey falls within international standards for reduced carbon dioxide, hydrocarbon and nitrous oxide emissions. Specifically designed fuel injection and exhaust systems mean that Honda LEV engines are gentle on the environment without sacrificing performance.

Well into the future, the Odyssey will continue to care for the environment as most of the materials used in the car can be recycled.



We have set up the Honda TreeFund and are committed to fund the planting of 10 native trees for every new vehicle sold. We see this as a measurable way to help offset vehicle emissions.

ACCESSORIES



Add your own personal touch to the Odyssey's revolutionary design with a range of genuine Honda accessories. Upgrade the entertainment system, choose some low profile alloy wheels, then top it all off with a roof rack. Your Honda Agent can help you select the accessories for your Odyssey, and have them installed at the time of purchase.

CD stacker	Bumper corner protector	Towbar
Fog lights	Floor mats	Roof rack
Side mouldings	Boot liner	17" Alloy wheels
Door visor	Wooden shift knob	Rear vision mirror
Gold emblem	Side step garnish	

COLOURS: EXTERIOR



Premium White	Satin Silver	Nighthawk Black	Royal Ruby Red	Desert Mist	Greyish Mauve
Pearl	Metallic		Pearl	Metallic	Metallic

INTERIOR



Beige Velour*	Grey Velour**	Beige Leather***
---------------	---------------	------------------

*VTI & VTI-S MODELS EXCLUDING SATIN SILVER
 **SATIN SILVER VTI & VTI-S ONLY
 ***ALL VTIL & VTIL-S MODELS

SPECIFICATIONS

MECHANICAL

16-valve PGM-Fi engine	•	•	•	•
2.4 litre DOHC with maximum power of 118kW @ 5500rpm & maximum torque of 218Nm @ 4500rpm	•	•	•	•
i-VTEC (Intelligent Variable Valve Timing with Electronic Lift Control) performance enhancing technology	•	•	•	•
LEVII (Low Emission Vehicle) rating	•	•	•	•
91-octane fuel. 65 litre tank capacity	•	•	•	•
5-speed auto transmission with SportShift, Grade Logic Control and Transmission Lock-Up Control	•	•	•	•
Front & rear independent double wishbone suspension with coil spring and front and rear stabiliser bars	•	•	•	•
Speed sensitive power assisted rack and pinion steering with VGR	•	•	•	•
300mm front ventilated and 305mm solid rear disc brakes with Anti-Lock Braking System	•	•	•	•
Double action foot parking brake	•	•	•	•
16" Steel wheels. 16x6.5JJ SP with 215/60 R16 tyres	•			
17" Alloy wheels. 17x7JJ AL with 215/55 R17 tyres (optional on VTIL-S)		•		
16" Alloy wheels. 16x6.5JJ AL with 215/60 R16 tyres			•	•

SAFETY AND SECURITY

Engine immobiliser. Remote central locking on all doors and integrated security alarm system	•	•	•	•
G-Force Control technology bodysell for maximum passenger protection (G-CON)	•	•	•	•
ABS (Anti-Lock Braking System) with EBD (Electronic Brakes Distribution) and EBA (Emergency Brake Assist)	•	•	•	•
Driver and passenger front i-SRS airbags	•	•	•	•
Side airbags in front seats with OPDS (Occupant Position Detection System) on passenger seat	•	•	•	•
Side curtain airbags for all 3 rows of seats	•	•	•	•
Twin side intrusion beams	•	•	•	•
Two front and four rear parking sensors	•	•	•	•
Impact absorbing body coloured bumpers	•	•	•	•
Seatbelts: (1st row) 3-point ELR with pretensioners and shoulder adjustor	•	•	•	•
(2nd row) 3-point ELR x 2, 2-point manual x 1	•	•	•	•
(3rd row) 3-point ELR x 2	•	•	•	•
5 child seat anchor points and child-proof locks	•	•	•	•

EXTERIOR

Body coloured bumpers, side sills, and powered mirrors	•	•	•	•
Chrome door handles and inserts	•	•	•	•
Integrated rear window antenna	•	•	•	•
Roof spoiler	•	•	•	•
Twin exhaust pipes with finisher	•	•	•	•
Front & rear mudflaps - black on VTI and body coloured on VTIL	•	•	•	•
Halogen headlamps (with light sensitive auto-on feature on VTIL and VTIL-S)	•	•	•	•
Fog lamps	•	•	•	•
2-speed and variable intermittent front wipers. Rear wiper	•	•	•	•
Sunroof			•	•
Front, rear and side skirts. Front honeycomb grille		•		•

INTERIOR

Seating capacity - 3 rows sitting 2/3/2 with headrests in all positions	7	7	7	7
Retractable/fold-down 3rd row 50/50 seats creating spacious flat floor loading area	•	•		
Power retractable/fold-down 3rd row 50/50 seats creating spacious flat floor loading area			•	•
Foldable split 2nd row 60/40 sliding and fold down seats creating even greater loading area	•	•	•	•
Cruise Control and remote stereo buttons on steering wheel	•	•	•	•
Power windows with remote all down and key all up feature and anti-trap	•	•	•	•
Flip down centre console with power and auxillary sockets	•	•	•	•
Tilt adjustable steering wheel	•	•	•	•
Climate control air conditioning with full control front row, fan control middle row and vents to third row	•	•	•	•
Manual seat height adjustment (driver)	•	•		
8-way electric power seat adjustor (driver)			•	•
3-D dash with instant fuel consumption gauge, trip meters and outside temperature display	•	•	•	•
Velour interior trim with woodgrain-look garnish	•	•		
Leather interior trim with woodgrain-look garnish, leather and wood grain look steering wheel			•	•
Heated front row seats - high and low options			•	•
Front driver and passenger armrests, 2nd row armrest	•	•		
Front driver and passenger adjustable armrests, 2nd row armrest			•	•
Security coded stereo tuner. Single in-dash CD player. Six speakers	•	•	•	•
Additional 8-disc CD stacker under front passenger seat			•	•
8 cup holders. Coin pocket. Sunglass holder	•	•	•	•
Passenger and drivers vanity mirror	•	•		
Passenger and drivers vanity mirror with illumination			•	•
Front and rear map reading lights. Door courtesy lights	•	•	•	•
Coat hook. Boot light	•	•	•	•

DIMENSIONS

Exterior Length (mm)	4780
Exterior Width (mm) / including door mirrors (mm)	1800/2068
Exterior Height (mm)	1550
Interior Length (mm)	2790
Interior Width (mm)	1535
Interior Height (mm)	1220
Wheelbase (mm)	2830
Track - Front/Rear (mm)	1560/1560
Ground Clearance (mm) empty / laden	119/110
Turning Circle (metres) / Radius (metres)	10.8/5.4

CAPACITIES

Boot capacity (VDA litres) rear seat up	245L
Boot capacity (VDA litres) rear seat down - second and third rows / third rows. (Up to window line)	1056L/674L
Maximum warrantable towing weight (kg), seven passengers	720
Kerb weight (kg)	1670

36 MONTH
 OR 100,000 KILOMETRES
 WHICHEVER COMES FIRST
 BODY AND MECHANICAL WARRANTY

Every new Honda comes with a body and mechanical warranty and 24 hr road-side assistance.

G-CON
 G-FORCE CONTROL TECHNOLOGY

LEV
 LOW EMISSION VEHICLE