

**HONDA**  
The Power of Dreams

**FREED**

**FREED**



**KAHMOTOR**  
(A MEMBER OF ORIENTAL HOLDINGS BERHAD)

For more information on the all-new Honda Freed, visit [www.honda.com.sg](http://www.honda.com.sg) or a **Kah Motor showroom**.  
Ubi Showroom, 370 Ubi Road 3, Singapore 408651. Tel 6840 6888. Mon to Sat 9am-7pm, Sun 10am-7pm.  
Alexandra Showroom, 255 Alexandra Road, Singapore 159937. Tel 6339 9880. Mon to Sat 9am-7pm, Sun 10am-7pm.





Life is a breeze with the new  
Honda Freed.

## The power of FREEDOM.

In keeping with Honda's tradition for creating stylish family cars, one multi-utility vehicle (MUV) has broken new ground and surpasses all that have come before it. Introducing the new Honda Freed, a compact MUV specifically catering to the exciting lifestyle and needs of urban families.

The innovative low-floor, low centre of gravity technology adopted by the Honda Freed, create outstanding space, performance and usability. And more importantly it sets new standards in the compact class.

The new Honda Freed is the vehicle just made for you to enjoy every day. Come on, it's time to get free.



Actual equipment may vary from picture shown.



## Comfort and privilege you can feel.

The Honda Freed's uniform design seamlessly fuses a sharp triangle shape with a voluminous square box, creating its unique and distinctive styling and maximizing space.

Its compact body size is one of the many reasons why the Honda Freed will become a great success in Singapore. It makes navigating in narrow streets and tight multi-storey car parks a breeze. Visibility, effortless steering and a powerful 1.5L i-VTEC engine make a life of zipping around from place to place just so easy. Inside, the generous space comfortably seats seven adults with

a convenient 2-2-3 arrangement. While the 2740mm wheelbase and Honda's ingenious flat floor design ensure ample legroom even with a full car.

Offering a one-of-a-kind driving experience, the Honda Freed gives you the freedom no other vehicle in its class can provide. Life is a breeze with the Honda Freed.

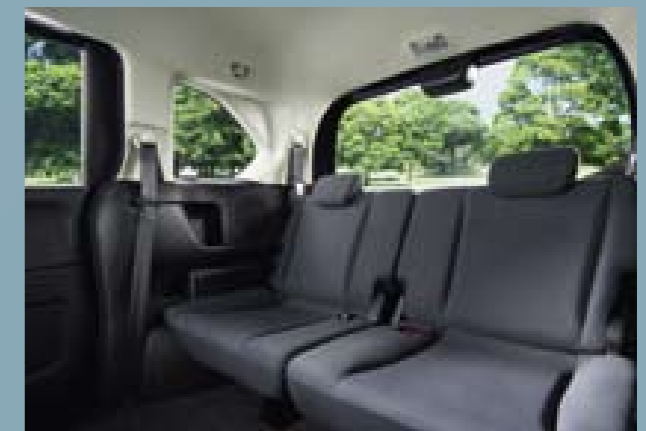

Actual equipment may vary from picture shown.



A bold opportunity is waiting.

Actual equipment may vary from picture shown.





## Be at one with your surroundings.

The interior design was inspired by the image of an open, light filled café. It needed to be more than just high quality, it needed to feel spacious and friendly – somewhere you're always happy to be.



The two-layer console puts all the controls at the driver's fingertips. Its wrap-around design keeps everything within the driver's eye line to make driving safer for everyone. For example - the multi information display shows instantaneous fuel economy, continuously. At the flick of a switch, it can display accumulated distance, trip distance, average fuel consumption as well as the estimated cruising range before the next petrol top up.

More importantly, the operating system functions have been intelligently positioned around the driver's seat. The audio and air conditioning controls are placed in the center of the instrument panel where they are clearly visible and can be easily operated by the driver or front passenger.

Actual equipment may vary from picture shown.



## What you want, when you want.

The fully automatic\* air conditioning has cleverly designed outlets to achieve cool driving comfort. Located high on the instrument panel, the air conditioning ducts ensure enhanced efficiency at the same time as well as delivering a comfortable temperature to all three rows.

Comfort was a key factor in achieving our vision. That's why the first and second rows are fitted with 'Captain Seats.' These large, luxurious and comfortable seats bear a slim back and rounded shoulders, firmly holding your body in the correct posture. They also allow passengers in the third row to move freely without having to adjust the row in front.

The one step floor design, easy to reach door handle and adjustable door opening steps all provide easy and secured access. And with rear sliding doors at both sides opening a full width of 600mm, getting in and out of the Freed is a breeze even in narrow spaces. But the convenience doesn't stop there. The doors can be operated with a touch sensor at the driver's seat, or by the keyless entry remote control system. And for additional safety, they will automatically close from the 'door-ajar' position.^ The front doors too, despite being compact, are cleverly designed with a forward-leaning hinge and spacious headroom allowing for easy access.

\* Available on the Freed 1.5EX model.

^ Available on the Freed 1.5EX model with power sliding doors.



Actual equipment may vary from picture shown.

## Stylish features.

The Honda Freed offers the kind of space required to meet the varying needs of a family. With its larger, low-floor tailgate opening (height of 1,120mm and maximum width of 1,160mm) enhancing storage space, it's practical for loading and unloading everything from sports equipment to furniture. The third row can also be conveniently stowed away to create even more space.

And with its ingenious seating arrangement that provides every row with ample legroom and headroom, the whole family can sit, relax and be together without feeling on top of each other. And all the while enjoying the freedom and spaciousness the Honda Freed has to offer - like individual beverage holders and convenient storage spaces within easy reach of everyone.



Hand grip for easy access.



Keyless entry remote control system.

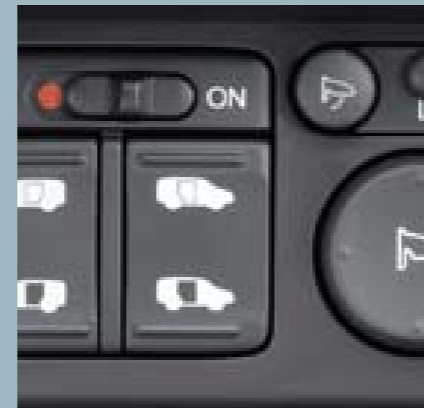

Touch sensor at the driver's seat.



3rd row flip-up seats for ample equipment space.



Wider door opening angle.



## Clever conveniences.

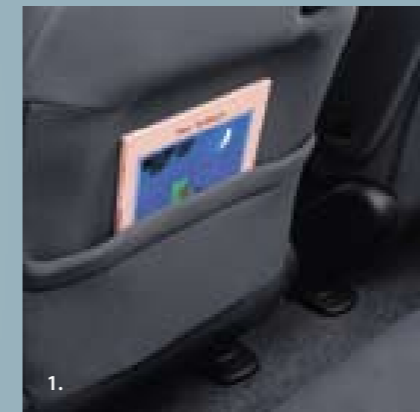

1.

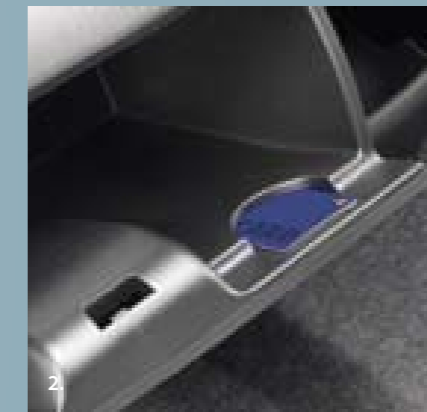

2.



3.

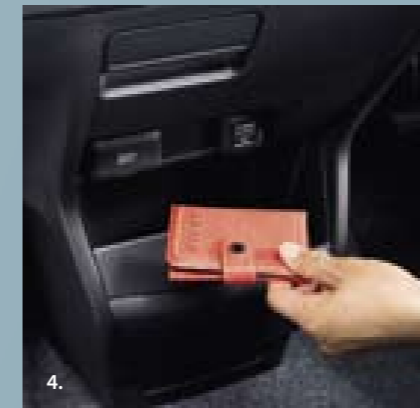

4.

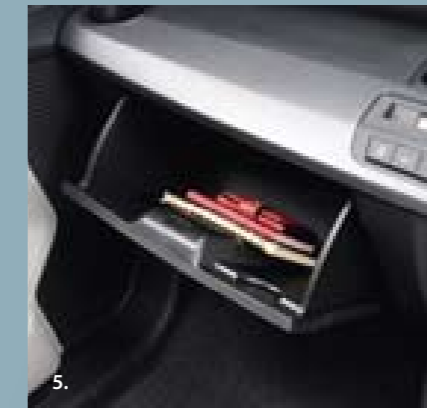

5.



6.



7.

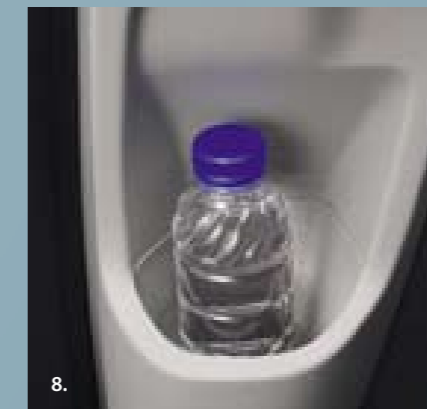

8.

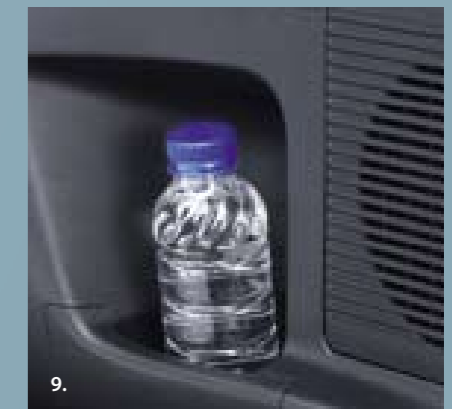

9.



10.

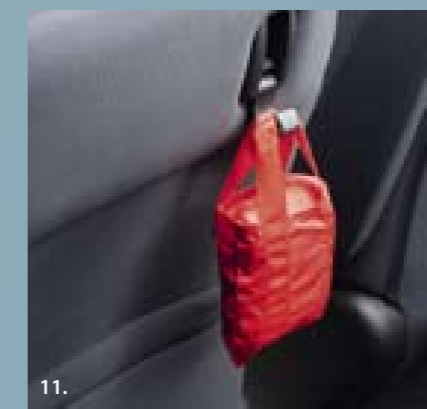

11.

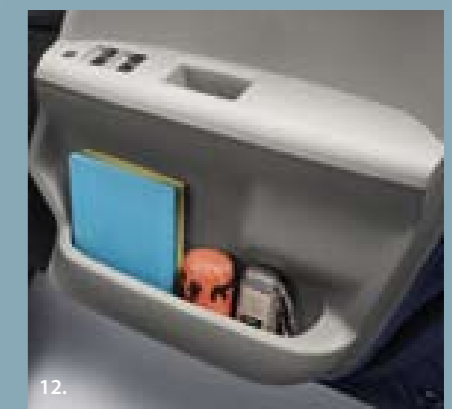

12.

1. Backrest pocket. 2. Glove box card holder. 3. Lower centre storage box. 4. Illuminated centre tray. 5. Glove box. 6. Driver and front passenger drink holders. 7. Centre console drink holders. 8. Second row side door drink holders. 9. Rear side door drink holders. 10. Sun visor ticket holder. 11. Convenient backrest hooks. 12. Driver and front passenger large door pockets.

Actual equipment may vary from picture shown.





## A break out performance.

The Honda Freed is about more than just style and comfort. Honda's new and powerful 118ps (87kW) 1.5L i-VTEC engine power delivers powerful performance. Its ample 144nM of torque (at 4,800rpm) allows strong, smooth acceleration on both flat and hilly terrain. Coupled with a newly developed 5-speed automatic transmission, the Honda Freed is a satisfying drive both in the city and on the highways. At the same time its advanced i-VTEC design enhances its fuel economy at both high and low speeds. It gives you the kind of performance you want as well as everything you need to enjoy sporty driving.



## Your freedom is at hand.



Because of the compact engine placement and power train, handling is as easy as can be. The turning radius is a mere 5.2m – very much like that of the compact Honda Jazz. And with an overall width and height of 1,695mm and 1,735mm respectively, it turns navigating through narrow city streets and parallel parking into simple tasks. Together with its impressive fuel economy, the Honda Freed is the complete car for the urban lifestyle.

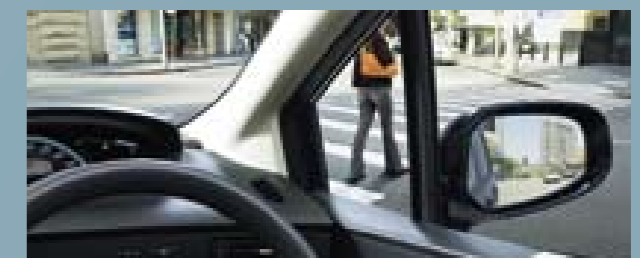

The tilt steering wheel adjusts the wheel up and down to the driver's most natural position. It's these touches that make the Honda Freed so special. But it doesn't stop there. The thinner A-pillar creates a panoramic view which not only helps minimise blind spots but also provides all passengers a refreshing view of what's ahead on the road.

Actual equipment may vary from picture shown.





## Effortless driving means it's always smooth sailing.

Sometimes it's the things you don't notice that make a car so special. The Honda Freed is packed with so many little touches that add to your driving pleasure, that what noticeable is its refined engineering.

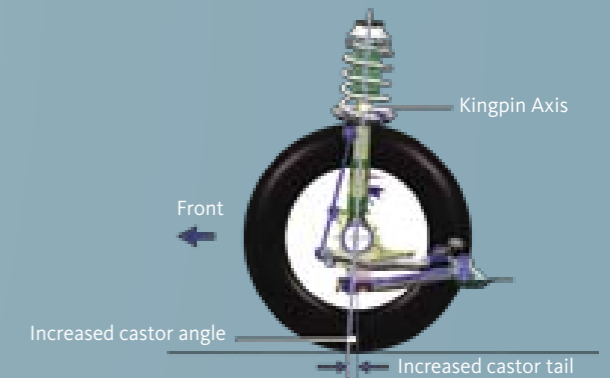

Advanced Honda technology reduces cabin noise in several ways including uniquely designed sound insulation and damping, specialised engine position and specific tuning of windows and panels - resulting in a more stable drive. And stability is a key element in the Honda Freed. That's why it features McPherson strut front suspension, which combines flexibility, high stability and manoeuvrability in both the front and rear. And by increasing the rigidity of the suspension mounting points, the front is more nimble and responsive. Coupled with the greater control offered by Electronic Power Steering (EPS), the Honda Freed has brilliantly responsive handling.

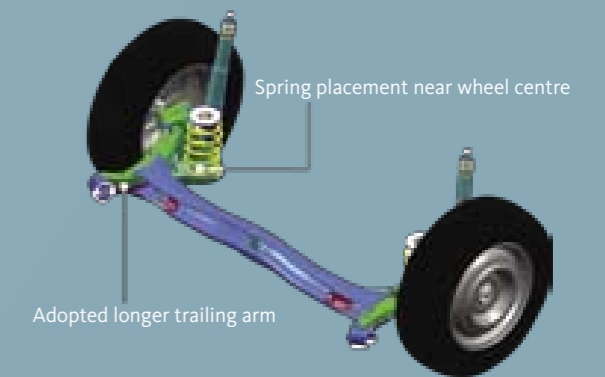

Everything is made easier for you to enjoy. Even down to the high-tensile steel that has been used in both sliding doors and tailgate, ensuring their strength and efficiency while maintaining light weight, so they open with ease.



## Careful and carefree.

Style, performance and comfort are all important but the Honda Freed would not be complete without its comprehensive safety engineering.

The Honda Freed is designed with Honda's advanced crash safety technology, GCON. This system reduces the impact of collisions through highly efficient energy absorption areas of the car, shielding the cabin from collision force. However there are several systems in place to prevent a collision from ever occurring. The Anti-lock Braking System (ABS) helps you overcome potentially dangerous situations such as wet roads and emergency braking, which restore traction and stability. This works in conjunction with the Brake Assist (BA) to help you stop quickly, smoothly and safely.

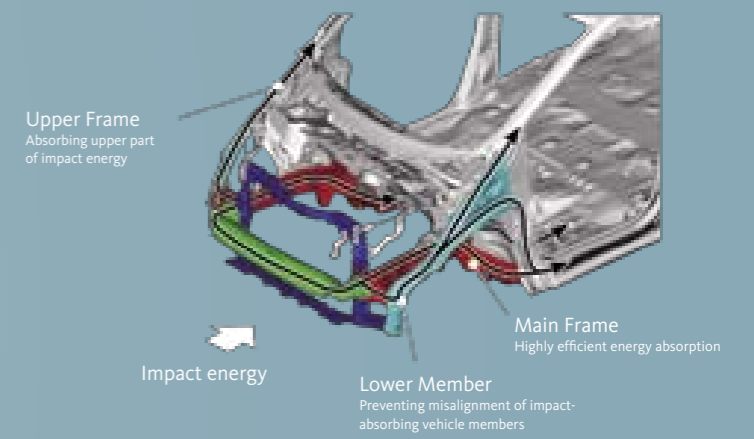
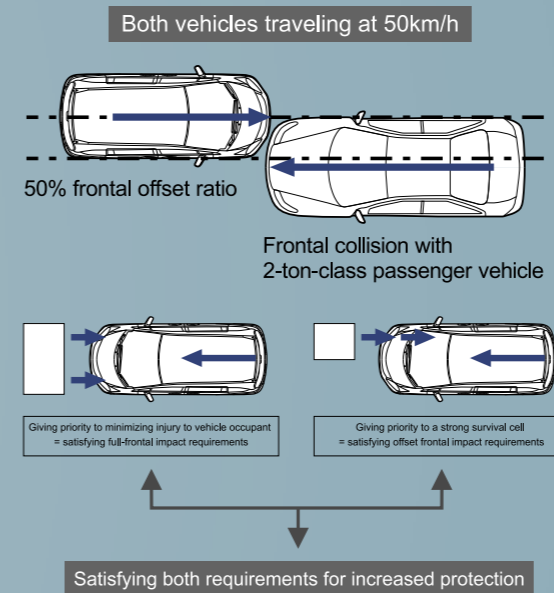
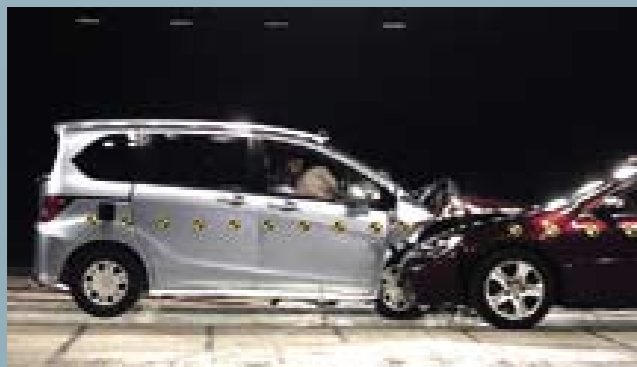

An impact is the last thing you'd want to happen in the Honda Freed. But in the event of a collision the front air bag system helps protect the head and neck of the driver and the front passenger. The GCON body design also forms a protective shell over all occupants. Impact energy is cleverly channelled to the floor, potentially reducing impact by effectively dispersing the energy away from the occupants.

Safety design takes the Honda Freed to a new level with pedestrian safety. To mitigate the impact on pedestrians during an accident, Honda adopted an impact dispersing system that spreads the force of the car's impact. The front hood features an impact absorbing design. Hinges and wipers are also designed to collapse and tear away to reduce injury.

● **Shock-Absorbing Hood Hinge Structure**  
Easily deformed hood hinges help absorb shock during collisions.

● **Shock-Absorbing Windshield Frame**  
Easily deformed windshield sill helps absorb shock during collisions.

● **Shock-Absorbing Wiper**  
Detachable wiper arm helps absorb shock during collisions.

● **Shock-Absorbing Hood**  
Sufficient space between the hood and the engine provides the space needed to help absorb shock during collisions.

● **Shock-Absorbing Bumper**  
Optimised bumper beam configuration provides the space needed to help absorb shock during collisions.

● **Shock-Absorbing Fender**  
Easily deformed fender attachment points help absorb shock during collisions.



Actual equipment may vary from picture shown.



# Commitment.



## Honda moves ahead in new directions, so you can explore more paths in life.

We're making new strides in moving technology. Honda is a company in motion, dedicated to finding better ways to harness movement for mutual well-being. Over a half-century we've developed a wide range of engineering technologies – from motorcycles and automobiles to power equipment, motorboat engines and aircraft – constantly challenging the limits of mobility for greater enrichment of life.

Our continuing research even includes a 10-year effort in robot development, leading to the creation of the world's first humanoid robot, ASIMO, that walks and runs on two legs. What does the future hold? The possibilities are as infinite as the Honda spirit of enthusiasm for exploration and innovation.



## We believe that every drop of fuel is important.

At Honda we're constantly thinking of new ways to reduce our impact on the environment. Conserving fuel has always been one of our top priorities. And thanks to our innovative i-VTEC technology we can make every drop of fuel do more and take you further. By utilising a revolutionary new valve control timing system, it can achieve superior power, low fuel consumption and lower emissions, which is not only good news for you, but it's also good news for the environment.



## Our progress is driven by energetic research.

Emerging from the realms of research, Honda fuel cell vehicles are now on the market. Having an originally-designed fuel cell stack that uses pressurised hydrogen to generate electricity, these fuel cell vehicles are not only quiet and quick-starting but also excellent in driving response. And the end result is high efficiency with zero emissions (including zero CO<sub>2</sub>).



## We keep surpassing our own stringent standards.

Honda continually strives to achieve ever higher levels of passenger and pedestrian safety. At our indoor Real World Crash Test Facility – the first of its kind in the world – we simulate actual traffic accidents much more faithfully than conventional tests, enabling us to develop vehicles that offer greater protection for people outside of our cars, as well as within.

# Why Kah Motor?

## Kah Motor gives your Honda a better resale value and a longer car life.

### Exclusive after-sales services.

Only when you opt for Kah Motor will you be entitled to the superior after-sales services devoted to your Honda. Enjoy the additional peace of mind of knowing that your Honda will be in the good hands of people who understand what's best.

### Reliable warranty from manufacturer.

The warranty coverage for your Honda is 3 years or 100,000 km, whichever comes first. In the short term, it is more convenient for your servicing needs. Over time, it just means improved life span for your car.

### Proprietary servicing equipment.

Your Honda will be handled only with authentic, high technology equipment from Honda Japan. The Honda Diagnostic Equipment will efficiently isolate any malfunction for swift rectification. Specially designed tools will prevent damage to components that may be costly to replace.

### Specialist care.

Our team of 128 Honda experts from the Kah Motor Service Division is at your service. These specialists undergo relentless technical skills upgrades under the Honda Individualistic Skill Training (IST) programme. They will recommend the best preventive measures for your car to save you from hefty bills in the future.

### Genuine components.

No corners are cut, as all the parts used at the Kah Motor Service Centres are 100% genuine and of the highest quality. The components are manufactured especially for Honda vehicles, and provide the best fit and performance.

### Round-the-clock assistance.

With the 24-hour breakdown and towing services from Kah Motor, your needs will be attended to any time of the day.

### Islandwide network.

Six strategically located Service Centres and two Body Repair & Paint Shops ensure that your Honda will be promptly serviced at your convenience.

### Higher resale value.

All these add up to a higher price you can fetch for your Honda in the resale market, should you decide to transfer ownership.

## Who else takes care of your Honda like one of its own?

Only Kah Motor provides you with the high quality services you deserve when you invest in a Honda. That's great peace of mind for you.

No one knows a Honda the way Kah Motor does. As the official exclusive distributor of Honda automobiles for more than 30 years in Singapore, Kah Motor is committed to providing the most comprehensive and reliable pre and post sales services.

Choosing a Honda is already a wise decision. Now, you can repeat that good judgement by choosing from Kah Motor.



## Kah Motor Rental & Leasing.

Rent or lease your favourite Honda from Kah Motor Rental & Leasing.

In addition to the standard features available in our rental cars, we also provide:

- 24-hour back-up/breakdown service
- Free delivery anywhere within Singapore (subject to min. 4 days rental)
- Free additional driver
- Replacement car in the event of accident or breakdown
- Free doorstep pick-up and delivery for cars due for service
- Insurance cover for Malaysia use

For interest in rental or leasing, please call 6840 6854.



As a Kahshare member, you are able to use car sharing to compliment your travel needs while your car is being serviced. Kahshare will be available at Alexandra, Ubi service centres. For more information about Kahshare, please visit [www.kahshare.com.sg](http://www.kahshare.com.sg) or call 6840 6858.

## KAH MOTOR SERVICE CENTRES

**Ubi Service Centre**  
370 Ubi Road 3  
Mon to Fri: 8am to 6pm  
Sat: 8am to 5pm

**Leng Kee Service Centre**  
255 Alexandra Road  
Mon to Fri: 8am to 5:30pm  
Sat: 8am to 5pm

**Mandai Service Centre**  
6A Mandai Estate  
Mon to Fri: 8am to 5:30pm  
Sat: 8am to 5pm

**Dunearn Service Centre**  
314 Dunearn Road  
Mon to Fri: 8am to 5:30pm  
Sat: 8am to 3pm

**Jurong Service Centre**  
311 Jalan Ahmad Ibrahim  
Mon to Fri: 8am to 5:30pm  
Sat: 8am to 3pm

**Thomson Service Centre**  
80 Upper Thomson Road  
Mon to Fri: 8am to 5:30pm  
Sat: 8am to 3pm

**Body Repair & Paint Centre**  
15 Ubi Road 4  
Mon to Fri: 8am to 5:30pm  
Sat: 8am to 5pm

**Body Repair & Paint Centre**  
6A Mandai Estate  
Mon to Fri: 8am to 5:30pm  
Sat: 8am to 5pm

**Call 6841 3838  
to book your next service  
appointment.**



# Freed Specifications.

DESCRIPTION	FREED 1.5	FREED 1.5 EX
<b>DIMENSIONS</b>		
Overall Length (mm)	4215	4215
Overall Width (mm)	1700	1700
Overall Height (mm)	1735	1735
Wheelbase (mm)	2740	2740
Tread (mm) – front	1478	1478
– rear	1466	1466
Ground Clearance (mm)	165	165
Curb Weight (kg)	1330	1355
Turning radius – at body (m)	5.6	5.6
– at wheel centre	5.2	5.2
<b>ENGINE</b>		
Engine Type	Water Cooled 4-stroke SOHC i-VTEC	Water Cooled 4-stroke SOHC i-VTEC
Fuel Supply System	PGM-FI	PGM-FI
Bore x Stroke (mm)	73x 89.4	73x 89.4
Displacement (cc)	1497	1497
Compression Ratio	10.4	10.4
Maximum Power kw[ps]/rpm	87[118]/ 6600	87[118]/ 6600
Maximum Torque N-m[kg.m]/rpm	146[14.8]/4800	146[14.8]/4800
<b>TRANSMISSION</b>		
AT Clutch Type	Torque converter with lock-up clutch	Torque converter with lock-up clutch
AT Transmission Type	Electronically Controlled 5-speed Auto, 1 speed Reverse	Electronically Controlled 5-speed Auto, 1 speed Reverse
<b>STEERING</b>		
Type	Rack and Pinion with Electric Power Assist	Rack and Pinion with Electric Power Assist
<b>BRAKE SYSTEM</b>		
Brake Type – Front	Ventilated Disc	Ventilated Disc
– Rear	Drums	Drums
Parking Brake Type	Hand Brake	Hand Brake
Brake Circuit	Split service brake	Split service brake
<b>SUSPENSION</b>		
Suspension Type – Front	Strut	Strut
Suspension Type – Rear	Axle torsion beam	Axle torsion beam
Shock Absorber	Gas Pressurised	Gas Pressurised
<b>TYRES AND WHEELS</b>		
Tyre Size	185/65 R15	185/65 R15
Wheel Size/Type	15 x 5 1/2J AL	15 x 5 1/2J AL
<b>OTHERS</b>		
Fuel Tank (ltr)	42	42
<b>EXTERIOR</b>		
Halogen Headlights	✓	✓
Alloy Wheels	✓ (15")	✓ (15")
Door Mirror – Electrically operated, electric folding	✓	✓
– with integrated side turn	–	✓
Door Handles – Grab type	Body-coloured	Body-coloured
Rear Trunk Garnish	Body-coloured	Chrome

# Freed Specifications.

DESCRIPTION	FREED 1.5	FREED 1.5 EX
<b>CABIN</b>		
Upholstery	Black	Black
Climate Control System – Type	Manual	Climate Control
Filter (Odour reducing/ High dust maintenance)	✓	✓
Audio – 4 speaker system	✓	✓
Steering Wheel 3 spoke, urethane	✓	✓
Adjustment	Tilt only	Tilt only
Driver Seat – Driver seat with armrest	✓	✓
Row 2 Seats – Captain seats with armrests	✓	✓
Row 3 Seats – 50:50 split, stowaway design	✓	✓
<b>CONVENIENCE</b>		
Vanity Mirrors – x2 (Front Driver and Front Passenger)	✓	✓
Map Light, Interior Light	✓	✓
Cup Holders – Front, 3 nos	✓	✓
– Rear, 3 nos	✓	✓
Head Rest – Front	✓	✓
– Row 2: 2 headrests,	✓	✓
– Row 3: 2 X retractable	✓	✓
Convenience Hook (Front passenger seat back)	✓	✓
Rear Doors – Manual type	✓	–
– Power sliding, L+R doors, with anti-pinch function	–	✓
<b>ELECTRICAL</b>		
Power Windows Front and Rear	✓	✓
Power Door Locks	✓	✓
Front wipers	Intermittent	Variable intermittent
<b>SAFETY</b>		
Anti-lock Brake System with EBD and Brake Assist	✓	✓
SRS Airbags – Front	✓	✓
Fog Lights – Front	–	–
Seat Belts – 1st Row: 3-pt ELX x2, pretensioner with load-limiter	✓	✓
– Second Row: 3-pt ELR x 02	✓	✓
– Third Row: 3-pt ELR x 02, 2-pt lap belt x 01	✓	✓
Automatic Door Locks – Activated by vehicle speed	✓	✓
High Mount Stop Light	✓	✓
Keyless Entry System (2 Transmitters)	✓	✓
Security Alarm	✓	✓
Engine Immobiliser	✓	✓



Luminous Blue Pearl (B - 556P)



Alabaster Silver Metallic (NH - 700M)



Polished Metal Metallic (NH - 737M)



Brilliant White Pearl (NH - 636P)



Crystal Black Pearl (NH - 731P)