

The Honda Accord 2006





Model shown throughout is 2.4 i-VTEC EX with ADAS



Exterior Design	5
Interior Design	13
Technology	23
Performance	33
Product Detail	43
Model Line-up	49
Specification	55
Options	59
Glossary	67
Finance	69
Aftercare	71
Environment	73
Innovation	75
Colour Options	77



Always pushing the boundaries. If you thought the Honda Accord could not become more distinctive in its styling, more sporty in its nature, or more refined in its level of luxury, you're in for a pleasant surprise. The Accord 2006 has even more dramatic road presence with refined lines and ultra smooth shape. But there's more to the new Accord than breathtaking looks and style. Under the skin you'll find innovation after innovation. Like ADAS (Advanced Driver Assist System). Designed to increase comfort and safety, it utilises both LKAS (Lane Keeping Assist System) and ACC (Adaptive Cruise Control). It's pure Honda, and takes the award winning Accord to a new dimension.



One glance tells you it's a performance car. Class-leading aerodynamics fused into a satisfyingly smooth shape. The new Accord is easy on the eye yet with commanding presence. The low stance on the road, accentuated by the 17" alloys (standard on Type-S models and 2.4 i-VTEC EX with ADAS) and low profile tyres hint at the exceptional performance, whilst the chrome handles and electric fold-away door mirrors hint at its refinement.



More punch, but quieter. The exciting shape, refined aerodynamics and high quality design of the new Accord are more than matched by its exhilarating performance. Strong and lightweight, with a choice of 2.2 i-CTDi diesel (now available with 6-speed transmission) and 2.0 i-VTEC or 2.4 i-VTEC petrol engines. Whichever model you choose, you'll find it surges ahead effortlessly whilst minimising noise and vibration.



A driver's dream. In developing the new Accord, our engineers scrutinised every detail, improving performance at every opportunity. Innovation followed innovation, outside and inside. So you'll find the new Accord has re-sculpted bumpers to help the air flow more easily around them, re-designed wipers that fit flatter and flusher to the windscreen resulting in reduced wind noise. High Intensity Discharge headlights (HID – available on 2.4 i-VTEC EX with ADAS), and a new V shaped grille. This not only looks imposing, but improves aerodynamics. With an even more luxurious interior and agile handling, it's an immensely satisfying car to drive.





Luxurious and serene. The interior of the Accord is a very special place to be. Sumptuous materials and sophisticated design combine with the latest innovations for total comfort and control. There's a new sporty gearshift, individual climate control zones for both driver and passenger, deep arm rests and a multi-function driver computer. On EX models you'll find leather and electrically adjustable heated seats. It's typically refined and understated. Typically Honda.

Intuitive control. The driver environment in the new Accord is spacious, relaxed and comfortable. Controls are intuitively where you'd expect them to be, just a fingertip away, whilst driver information is clear and easy to take in at a glance. Speak to the intelligent voice recognition Satellite Navigation system and it automatically finds the best route to where you want to go. Audio volume increases with speed without the need to touch a thing (although there is steering wheel volume control if you wish to). There's even a Bluetooth® Hands Free Telephone system (HFT). Everything is designed to help you focus on the road and keep your hands on the wheel.

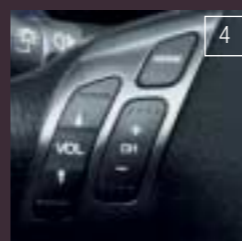
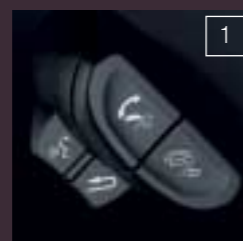

1. Bluetooth® Hands Free Telephone system (HFT) is an innovative hands free solution enabling you to take those essential telephone calls, while providing an overall safer driving experience. **2. (A)** Lane Keeping Assist System (LKAS) button activates the system initially. **(B)** Distance button then changes the selected distance to the vehicle ahead. **3.** Main switch activates the Adaptive Cruise Control (ACC) and LKAS system. **4.** Audio controls for CD or radio.



Any excuse for a long journey. Head-turning on the outside, the new Accord is remarkably spacious on the inside. With five passengers comfortably seated, there's still plenty of room for heads, legs and elbows. The seats are ergonomically designed with lumbar supports that mould themselves to fit every body shape, and are upholstered in new improved fabric, including soft grain leather on EX models. For long family journeys or weekends away, the Accord is the perfect place to be.



Little things make a big difference. Every car has the same basic ingredients, but it's Honda's ability to take them beyond the norm that makes such a difference. In the new Accord, for example, the gearshift is sporty and tactile and on our 5-speed automatic transmission, grade logic recognises different driving styles and conditions and will select the optimum gear ratio for you. The multi-function driver computer keeps the driver up to date on everything from current fuel consumption to miles left in the tank, whilst Bluetooth® technology means taking those essential phone calls is safer and less intrusive. And if you need to find your way, simply speak to the Satellite Navigation system without taking your eyes from the road.





Advanced Driver Assist System (ADAS)

ADAS is a combination of both Adaptive Cruise Control (ACC) and Lane Keeping Assist System (LKAS). Using the very latest technology these features are designed to make driving less stressful, more enjoyable and ultimately safer.

ADAS is available on 2.4 i-VTEC EX automatic.

Adaptive Cruise Control (ACC)

Keeping you at a safe distance. The new Accord is one of the safest cars for motorway driving because it's fitted with Adaptive Cruise Control (ACC). A radar fitted behind the Honda badge on the grille calculates and monitors the distance between you and the car in front. If the gap closes, it overrides your pre-set cruise control speed, decelerates, and applies brakes if necessary. When the car in front moves away again, it accelerates to the speed you previously set. If the radar senses a car from another lane cutting across in front of you, and an urgent response is required, the system starts braking and alerts the driver with a warning light and buzzer, prompting the driver to apply the brakes. It makes those longer journeys less tiring, safer and more comfortable, and all the time you are in complete control.

Lane Keeping Assist System (LKAS)

The very latest technology. Lane Keeping Assist System (LKAS) is designed to improve main road driving by helping you stay in lane. The intelligent system identifies the boundaries of the vehicle's lane by processing images from a camera mounted above the windscreen. It then calculates the optimum steering effort needed to keep the car in the centre of its lane, applying torque to the steering wheel to help maintain a central position. The system also gives you audible and visual warnings if you start to stray towards or across a white line. Again, it's all designed to make driving simpler and safer.



“take me home”

Voice Activated Satellite Navigation

Voice Activated Satellite Navigation. In keeping with the high levels of refinement, the new Accord has a voice activated Satellite Navigation system. Once programmed to recognise your voice, in any one of 11 languages, it will follow your instructions to find the quickest and easiest route. Even taking you home from the farthest corner of Europe. As the system is constantly assessing traffic report data, it can quickly adjust the route to avoid roadworks, accidents, tailbacks or any other driving hazard.



Taking safety to a new level. You'd expect a car with impressive looks, handling, power and comfort to have equally impressive safety features. The new Accord does not disappoint. As well as airbags all round, including dual front, side and curtain, you'll find Anti-lock Braking System (ABS), Electronic Brake-force Distribution (EBD) and Vehicle Stability Assist (VSA) for safe, powerful braking. For further protection, engineers at our Tochigi crash centre, the biggest in the world, tested the Accords crash resilience in all possible directions. But it isn't just car occupants who need protecting. It's pedestrians too. So Honda developed Polar II, the most advanced crash test dummy in existence.

Taking safety to a new level. The new Accord has been built with a steel cage at its heart and body shell that disperses energy away from the cabin. There are even crumple zones to help protect pedestrians if required. At Honda everything is considered.



Polar II



VSA controlling understeer

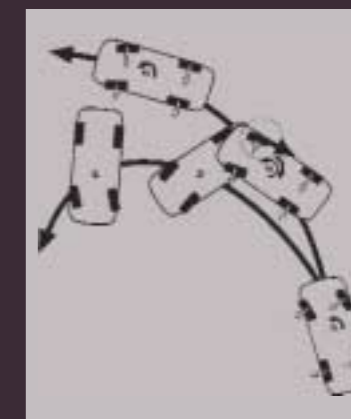

VSA controlling oversteer

VSA controlling oversteer, VSA controlling understeer:

Vehicle Stability Assist (VSA) - standard on the 2.2 i-CTDi diesel and 2.4 i-VTEC models (optional on the 2.0 i-VTEC models), helps you maintain control during cornering, acceleration and collision-avoidance manoeuvres. When it detects wheel-slip under acceleration, it applies braking to the affected wheel and reduces engine power until traction is regained.

Any understeer and oversteer that falls outside the system's predicted range of vehicle responses is also corrected automatically.



Now in even greater shape. The Accord was already an incredibly aerodynamic car. But still our engineers were not satisfied, so they built the highest specification wind tunnel in the world and reassessed every curve, every angle and every straight line to improve aerodynamics. And that means improved performance across the range.





Two petrol engines in one. With most cars you have to choose between performance and fuel economy. But the new Accord's i-VTEC petrol engines give you the best of both worlds. The innovative Variable Valve Timing and Electronic Control (VTEC) means maximum performance at motorway speeds and maximum economy at urban speeds. It's like having two engines in one. There are two petrol engines to choose from: a 2.0 i-VTEC engine which returns 38.2mpg at peak torque, and a 2.4 i-VTEC engine which takes the new Accord from 0-62mph in 8.0 seconds and still delivers 31.4mpg.

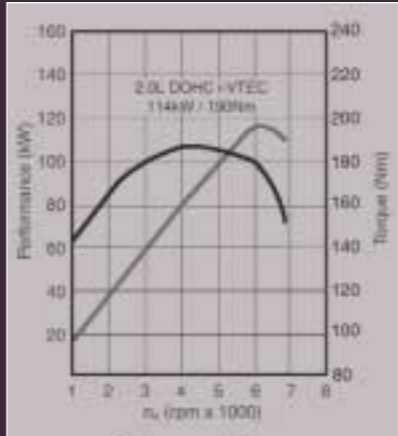

2.0 i-VTEC performance and torque

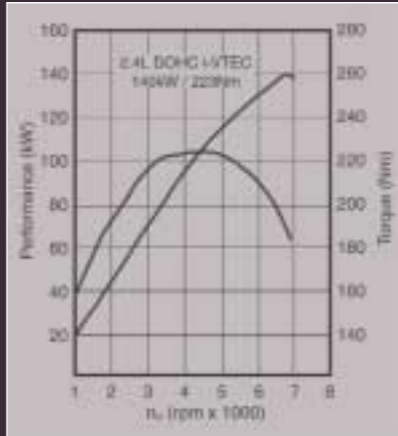

2.4 i-VTEC performance and torque

A diesel engine that's as quiet as a petrol engine. For the new Accord we wanted a diesel engine to match the sophistication and refinement of our petrol engines. So we used the revolutionary all-aluminium 2.2 i-CTDi diesel engine in semi-solid casting. Not only does it deliver outstanding power to weight ratio, it's stronger, stiffer and more compact, making it able to withstand class-leading levels of torque.

In fact, it has an award winning combination of balance, torque, power, fuel economy and emissions unmatched by any other diesel.



2.2 i-CTDi performance and torque



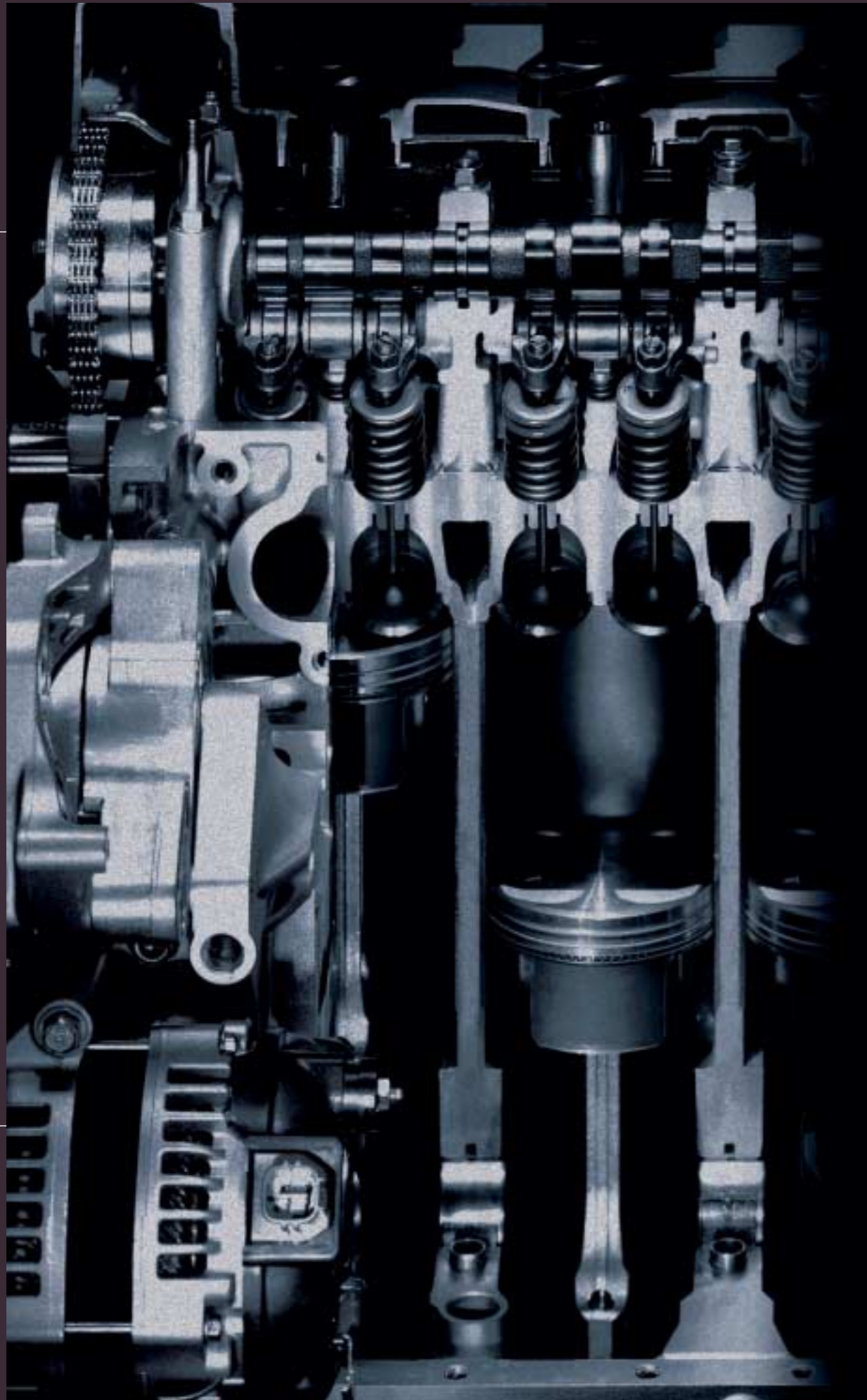

HondaJet



Formula-1



ASIMO

The more we innovate, the more we learn.

At Honda, innovation is in our blood. We're never satisfied. But it's not just the challenge to see if we can produce superior technology for its own sake. It's because by innovating in many spheres, we learn things that can be used to improve the performance and quality of all our products, including our cars. Which is why we're happy to have invested heavily in developing world-beating power boats, racing bikes with 557 Grand Prix titles, and ASIMO, the world's most advanced robot in manoeuvrability and voice recognition. With increasing podium places, we're even catching up fast in Formula-1. Then of course, there's our experimental, mould-breaking HondaJet which dramatically increases fuel economy by placing engines above the wing instead of underneath. With imagination and innovation, anything is possible. That's why we believe in the power of dreams.



VOL
CH
+
-
132

AM/FM



MAIN
RES
ACCEL
DECEL
SET
CANCEL

VOL
PWR
P/S

SRS
AIRBAG

RES
SET



RESET

OFF
AUTO
LO
3E

6
5
4
3
2
1
x1000rpm

80
60
40
mph
100
120
140
160
180
200
220
240
260
km/h



1



2



3



4



5



6

1-2. The central armrest provides comfort and additional storage space. **3.** Standard on SE and EX models, a sunroof brings light and a feeling of space into the car. **4.** Multi-jog dial controls the Satellite Navigation system and makes moving from screen to screen simple. **5.** The dashboard features a secure storage compartment, well positioned for driver and front passenger. **6.** For added comfort, heated leather seats are standard on EX models.



1



2



3



4



5



6



7

1-2. Washers on both headlights ensure maximum light on the road ahead whatever the conditions (standard on EX models). **3.** Quality detailing can be found throughout the Accord. **4.** A rear brake light mounted high on the rear screen is a welcome additional safety feature. **5.** The rear boot can be automatically opened with a push of a button on the key fob. **6.** The twin tailpipes on the Accord 2.4 i-VTEC models hint at its sporty nature. **7.** Door mirrors feature indicator repeaters for enhanced visibility. They are heated, electrically adjustable and will also fold inwards - ideal for parking in tight spots.

The same, only different. Choose the revolutionary 2.0 i-VTEC petrol, the award-winning 2.2 i-CTDi diesel with outstanding fuel economy or the refined 2.4 i-VTEC petrol.

Whether you complement this with the Type-S, giving a sporty look, or the EX with full leather interior, you're assured of performance and refinement with all the driving manners of a sporty saloon.

2.0 i-VTEC SE
2.0 i-VTEC Type-S
2.0 i-VTEC EX
2.2 i-CTDi Sport
2.2 i-CTDi EX
2.4 i-VTEC Type-S
2.4 i-VTEC EX
2.4 i-VTEC EX (with ADAS)





2.0 i-VTEC SE



2.2 i-CTDi Sport



*For full exterior colour options,
please see colour palette at the
back of brochure*



*For full exterior colour options,
please see colour palette at the
back of brochure*



2.0 i-VTEC Type-S / 2.4 i-VTEC Type-S



2.0 i-VTEC EX / 2.2 i-CTDi EX / 2.4 i-VTEC EX
(optional Satellite Navigation)



*For full exterior colour options,
please see colour palette at the
back of brochure*



*For full exterior colour options,
please see colour palette at the
back of brochure*

	2.0 i-VTEC SE	2.0 i-VTEC Type-S	2.0 i-VTEC EX	2.2 i-CTDi Sport	2.2 i-CTDi EX	2.4 i-VTEC Type-S	2.4 i-VTEC EX	2.4 i-VTEC EX (with ADAS)
Engine								
Type	DOHC i-VTEC	DOHC i-VTEC	DOHC i-VTEC	Common Rail Turbo Diesel	Common Rail Turbo Diesel	DOHC i-VTEC	DOHC i-VTEC	DOHC i-VTEC
Displacement (cc)	1998	1998	1998	2204	2204	2354	2354	2354
Maximum power (PS @ rpm)	155@6000	155@6000	155@6000	140@4000	140@4000	190@6800	190@6800	190@6800
Maximum torque (Nm @ rpm)	190@4500	190@4500	190@4500	340@2000	340@2000	223@4500	223@4500	223@4500
Recommended fuel rating (Research Octane Number - RON)	95 RON	95 RON	95 RON	Diesel	Diesel	95 RON	95 RON	95 RON
Fuel Economy (man/auto)*								
Urban (l/100km)	10.1/11.6	10.9/12.2	10.9/12.2	7.2	7.2	12.7	12.7/13.7	13.6
Urban (mpg)	28.0/24.4	25.9/23.2	25.9/23.2	39.2	39.2	22.2	22.2/20.6	20.8
Extra urban (l/100km)	5.9/6.0	6.3/6.3	6.3/6.3	4.5	4.5	6.9	6.9/6.9	6.7
Extra urban (mpg)	47.9/47.1	44.8/44.8	44.8/44.8	62.8	62.8	40.9	40.9/40.9	42.2
Combined (l/100km)	7.4/8.0	8.0/8.4	8.0/8.4	5.5	5.5	9.0	9.0/9.4	9.2
Combined (mpg)	38.2/35.3	35.3/33.6	35.3/33.6	51.4	51.4	31.4	31.4/30.1	30.7
CO ₂ (g/km)	176/189	189/200	189/200	145	145	214	214/223	218
Transmission								
5-speed manual	●	●	●	-	-	-	-	-
6-speed manual	-	-	-	●	●	●	●	-
5-speed automatic (sequential shift)	○	○	○	-	-	-	○	●
Performance								
Acceleration 0-62 mph (secs)	8.9/10.3	9.0/10.4	9.3/10.6	9.3	9.3	8.0	8.0/9.2	9.2
Maximum speed (mph)	137/134	135/134	135/134	132	132	141	141/141	141
Weights and Capacities (man/auto)								
Boot capacity seat up (litres, VDA method)	459	459	459	459	459	459	459	459
Fuel tank (litres)	65	65	65	65	65	65	65	65
Kerb weight (kg)	1379/1415	1365/1401	1365/1401	1477	1477	1398	1398/1436	1493
Turning circle - kerb to kerb (m)	10.8	11.4	10.8	10.8	10.8	10.8	10.8	11.4
Maximum towing weight with brakes (kg)*	1500	1500	1500	1500	1500	1500	1500	1500
Maximum trailer nose weight (kg)	75	75	75	75	75	75	75	75
Maximum roof load (kg)	65	65	65	65	65	65	65	65
Wheels and Tyres								
15" alloy wheels	●	-	-	-	-	-	-	-
16" alloy wheels	-	-	●	●	●	-	●	-
17" alloy wheels	○	●	○	○	○	●	○	●
18" alloy wheels	-	○	○	○	○	○	○	○
Space saver spare wheel	●	●	●	●	●	●	●	●
Tyres	195/65 R15	225/45 R17	205/55 R16	205/55 R16	205/55 R16	225/45 R17	205/55 R16	225/45 R17
Wheels	15X6JJ	17X7JJ	16X6.5JJ	16X6.5JJ	16X6.5JJ	17X7JJ	16x6.5JJ	17X7JJ
Sports suspension	-	●	○	-	-	●	○	●
Instruments and Controls								
Adaptive Cruise Control (ACC)	-	-	-	-	-	-	-	●
Lane Keeping Assist System (LKAS)	-	-	-	-	-	-	-	●
Multi-function driver computer	●	●	●	●	●	●	●	●
Dashboard illumination - White	●	-	●	-	●	-	●	●
Dashboard illumination - Red	-	●	-	●	-	●	-	-
Cruise control	-	●	●	●	●	●	●	●
Digital odometer (A / B trip)	●	●	●	●	●	●	●	●
Audible headlight on reminder	●	●	●	●	●	●	●	●
Illuminated ignition switch	●	●	●	●	●	●	●	●
Internally adjustable headlight height	●	●	●	●	●	●	●	-

	2.0 i-VTEC SE	2.0 i-VTEC Type-S	2.0 i-VTEC EX	2.2 i-CTDi Sport	2.2 i-CTDi EX	2.4 i-VTEC Type-S	2.4 i-VTEC EX	2.4 i-VTEC EX (with ADAS)
Front interior welcome light	●	●	●	●	●	●	●	●
Fuel filler release	●	●	●	●	●	●	●	●
External temperature gauge	●	●	●	●	●	●	●	●
Digital clock	●	●	●	●	●	●	●	●
Automatic headlight height	-	-	-	-	-	-	-	●
Front map lights	●	●	●	●	●	●	●	●
Rear interior welcome light	●	●	●	●	●	●	●	●
Low fuel warning light	●	●	●	●	●	●	●	●
Safety								
Dual front SRS airbags	●	●	●	●	●	●	●	●
Dual side SRS airbags	●	●	●	●	●	●	●	●
Dual curtain SRS airbags - front and rear	●	●	●	●	●	●	●	●
Anti-lock Braking System (ABS)	●	●	●	●	●	●	●	●
Electronic Brake-force Distribution (EBD)	●	●	●	●	●	●	●	●
Emergency Brake Assist	●	●	●	●	●	●	●	●
High level rear brake light	●	●	●	●	●	●	●	●
Side impact protection beams	●	●	●	●	●	●	●	●
Front seat belt pre-tensioners	●	●	●	●	●	●	●	●
Height adjustable front seat belts	●	●	●	●	●	●	●	●
5 x 3 point seat belts	●	●	●	●	●	●	●	●
ISOFix childseat restraint mechanism	●	●	●	●	●	●	●	●
Headlight washers	-	-	●	-	●	-	●	●
Dual tone horn	●	●	●	●	●	●	●	●
Front ventilated disc brakes	●	●	●	●	●	●	●	●
Rear disc brakes	●	●	●	●	●	●	●	●
Honda advanced pedestrian safety system	●	●	●	●	●	●	●	●
Vehicle Stability Assist (VSA)	○	○	○	●	●	●	●	●
Drive By Wire (DBW)	●	●	●	●	●	●	●	●
Security								
Rolling code ECU engine immobiliser	●	●	●	●	●	●	●	●
Honda Superlocks (deadlocks)	●	●	●	●	●	●	●	●
Externally visible Vehicle Identification Number (VIN)	●	●	●	●	●	●	●	●
Remote keyless entry	●	●	●	●	●	●	●	●
Central locking	●	●	●	●	●	●	●	●
High security integrated audio	●	●	●	●	●	●	●	●
Lockable glovebox	●	●	●	●	●	●	●	●
Locking wheelnuts	●	●	●	●	●	●	●	●
Perimeter security alarm	●	●	-	●	-	-	-	-
Interior and perimeter alarm (CAT1)	-	-	●	-	●	●	●	●

● standard ○ optional - not available

†Fuel consumption This test is designed to give an indication of on-road fuel consumption.

* Maximum towing weights are based on the ability of the car, with two occupants of 75kg each, to restart on a 12% gradient at sea level. At altitudes in excess of 1500 metres, engine output may drop with a reduction in towing capability. Extra weight, such as additional passengers or luggage, should also be deducted from the maximum towing weight.

	2.0 i-VTEC SE	2.0 i-VTEC Type-S	2.0 i-VTEC EX	2.2 i-CTDi Sport	2.2 i-CTDi EX	2.4 i-VTEC Type-S	2.4 i-VTEC EX	2.4 i-VTEC EX (with ADAS)
Exterior								
Automatic headlights with dusk sensor	-	-	●	-	●	-	●	●
Body colour bumpers	●	●	●	●	●	●	●	●
Body colour door mirrors	●	●	●	●	●	●	●	●
Chrome door handles	●	●	●	●	●	●	●	●
Electric adjustable and heated door mirrors	●	●	●	●	●	●	●	●
Glass electric tilt or slide sunroof with sunshade	●	-	●	-	●	-	●	●
Rear boot spoiler	○	○	○	●	○	○	○	○
HID headlights	-	-	-	-	-	-	-	●
Length (mm)	4665	4669	4665	4665	4665	4669	4665	4665
Width excluding door mirrors (mm)	1760	1760	1760	1760	1760	1760	1760	1760
Height (mm)	1445	1445	1445	1445	1445	1445	1445	1445
Wheelbase (mm)	2670	2670	2670	2670	2670	2670	2670	2670
Aerodynamic body kit	○	●	○	○	○	●	○	○
Front foglights	○	●	●	●	●	●	●	●
Single chrome exhaust	●	●	●	-	-	-	-	-
Twin chrome exhaust	-	-	-	-	-	●	●	●
Chrome window and grille surround	●	●	●	●	●	●	●	●
Standard slat front grille	●	-	●	●	●	-	●	●
Mesh front grille	-	●	-	-	-	●	-	-
Rear screen integrated aerial	●	●	●	●	●	●	●	●
Heat absorbing tinted windows	●	●	●	●	●	●	●	●
Electric folding door mirrors	●	●	●	●	●	●	●	●
Mirror integrated indicators	●	●	●	●	●	●	●	●
Comfort and Convenience								
Auto dimming rear view mirror	-	-	●	-	●	-	●	●
Tilt and telescopic steering wheel adjustment	●	●	●	●	●	●	●	●
Leather multi-function steering wheel	-	●	●	●	●	●	●	●
Organ accelerator pedal	●	●	●	●	●	●	●	●
Rain sensing windscreen wipers	-	-	●	-	●	-	●	●
Ashtray - front and rear	●	●	●	●	●	●	●	●
Tie down hooks in boot	●	●	●	●	●	●	●	●
Hydraulic power assisted steering	-	●	●	●	●	●	●	●
Electric power assisted steering	●	-	-	-	-	-	-	-
Boot light	●	●	●	●	●	●	●	●
Front power socket	●	●	●	●	●	●	●	●
Dual zone climate control (left:right independent)	●	●	●	●	●	●	●	●
Cabin filter	●	●	●	●	●	●	●	●
Driver vanity mirror with lid in sunshade	●	-	-	-	-	-	-	-
Passenger vanity mirror with lid in sunshade	●	-	-	-	-	-	-	-
Driver vanity mirror illuminated with lid	-	●	●	●	●	●	●	●
Passenger vanity mirror illuminated with lid	-	●	●	●	●	●	●	●
Drivers foot rest	●	●	●	●	●	●	●	●
Sunglasses storage box	●	●	-	●	-	-	-	-
Rear cupholders	●	●	●	●	●	●	●	●
Driver seatback pocket	-	-	●	-	●	-	●	●
Passenger seatback pocket	●	●	●	●	●	●	●	●
Front electric windows	●	●	●	●	●	●	●	●
Rear electric windows	●	●	●	●	●	●	●	●
Leather wrapped gear knob	-	-	●	-	●	-	●	-
Alloy gear knob	○	●	○	○	○	●	○	-

	2.0 i-VTEC SE	2.0 i-VTEC Type-S	2.0 i-VTEC EX	2.2 i-CTDi Sport	2.2 i-CTDi EX	2.4 i-VTEC Type-S	2.4 i-VTEC EX	2.4 i-VTEC EX (with ADAS)
Seating								
8 way power assisted driver seat	-	-	●	-	●	-	●	●
4 way power assisted passenger seat	-	-	●	-	●	-	●	●
Driver's seat height adjustment	●	●	-	●	-	●	-	-
Front seat - sliding centre armrest	●	●	●	●	●	●	●	●
Front seat - three stage heating system	-	-	●	-	●	-	●	●
Driver seat lumbar support	●	●	●	●	●	●	●	●
Rear centre headrest and 3-point seatbelt	●	●	●	●	●	●	●	●
Rear seat central armrest	●	●	●	●	●	●	●	●
60:40 split folding second row seats	●	●	●	●	●	●	●	●
Leather upholstery	-	-	●	-	●	-	●	●
Fabric Upholstery	●	-	-	-	-	-	-	-
Sports Upholstery	-	●	-	●	-	●	-	-
In Car Entertainment (ICE)								
Stereo CD tuner with RDS	●	●	-	●	-	●	-	-
Premium 6 CD tuner with RDS	-	-	●	-	●	-	●	●
Front speakers	●	●	●	●	●	●	●	●
Rear speakers	●	●	●	●	●	●	●	●
Parcel shelf speakers	-	-	●	-	●	-	●	●
Tweeters	●	●	●	●	●	●	●	●
Speed adjusting audio volume	-	-	●	-	●	-	●	●
Bluetooth® Hands Free Telephone System (HFT)	○	○	○	○	○	○	○	●
Voice recognition DVD Satellite Navigation	-	○	○	○	○	○	○	●

● standard ○ optional - not available

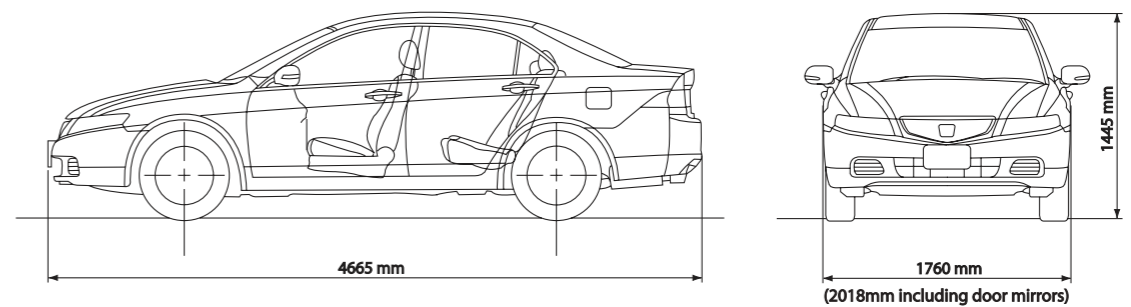





1. Front and rear bumper trim and side body trim **2.** Bluetooth® phone system – the most innovative hands free solution **3.** As you climb into your car, you are greeted by a high quality embossed door step garnish **4-5.** Sunshades are available for added sun protection for your passengers **6.** The keynote is sharpened looks and executive flair with door, front and rear trims.



Tailor your dreams. Your inspirations and dreams are as unique as you are. This is why Honda has developed a wide range of Honda Genuine Accessories that turn your driving experience into a truly personal one. For further information please contact your local dealer or visit www.honda.co.uk.



1. Front, rear and side skirts **2.** 17" Dynamic Alloy Wheel **3.** 18" Altimo Alloy Wheel, machine finished surface with grey silver inner finish **4-5.** Front bumper trims and rear skirt accentuate its lively character. **6.** Enhance the sporty lines of your Accord by adding a ducktail spoiler.



1. Leather steering wheel, leather/aluminium gearshift and blue ambient lighting adds a cool atmosphere to the interior of your Accord 2. Designed to protect your Accord's interior, this trunk tray is flexible and perfectly fits in your boot 3. CD disc changer that allows you to stow up to 8 of your favourite CDs 4. Range of childseats are available 5. Floor carpets prevent wear within the cabin. Available in black or ivory.

GLOSSARY

ABS The Anti-lock Braking System prevents the wheels from locking when the brakes are applied in an emergency, reducing the possibility of a skid on wet, icy or loose surfaces, and enabling the driver to retain steering control.

Adaptive Cruise Control (ACC) uses information from a millimetre-wave radar mounted inside the front grille to measure the distance to the vehicle ahead, whilst yaw rate sensors use vehicle speed to detect the safe driving parameters. In addition to maintaining a set speed, ACC is also able to automatically regulate both the vehicle speed and its distance to the vehicle ahead travelling in the same lane. This reduces the burden of motorway (or similar road) driving and enhances driver comfort. This system is available on the 2.4 i-VTEC EX automatic with ADAS.

ACC receives the signals from the millimetre-wave radar sensors to recognise the presence and the speed of the vehicle ahead, thus calculating the distance separating the two. The analysis of the impulses from the radar and their frequency variation makes it possible to calculate the exact distance and the relative speed between the vehicles. When this distance is reduced to below a predetermined value, the system instantly decelerates the vehicle through throttle control and, if necessary, by application of the brakes. In instances where quicker deceleration is required, such as sudden braking by the vehicle in front, the system starts braking and alerts the driver with a warning light and buzzer, prompting the driver to apply the brakes. If the vehicle ahead changes lane or the distance increases again, then the system returns the vehicle speed to the predetermined value.

ACC only operates if all the following conditions are fully fulfilled:

- the vehicle speed is set between 20 and 112 mph
- the main switch is activated

Advanced Driver Assist System (ADAS) is the Honda technology that utilises both LKAS (Lane Keeping Assist System) and ACC (Adaptive Cruise Control) to increase drive comfort and maximise safety.

Aerodynamics Aerodynamics refers to the ability of a car to overcome the resistance or 'drag' generated by its body as it moves through the atmosphere.

The lower the Coefficient of Drag (Cd) the more aerodynamic the shape. An aerodynamic shape is more fuel efficient, quieter and keeps the car firmly on the road.

The Cd value multiplied by the cross section area of the car is the wind drag of the car. The new Accord's Cd value of 0.26 is the best in its class.

Brake Assist If you have to make an emergency stop, the system detects the quick pedal action and automatically boosts braking power to reduce the stopping distance.

CO₂ Carbon dioxide is one of the exhaust gases believed to be one of the causes of the green house effect. The lower the CO₂ emissions, the better for the environment.

Common rail Common rail diesel engines have a reservoir of highly pressurised fuel close to the cylinder heads. As well as allowing extremely precise amounts of fuel to be injected into the combustion chamber very quickly, the pressure means the fuel forms a finer mist, so burns more efficiently. This makes the engine more economical, and reduces noise, smoke and emission levels.

Double wishbone suspension This wheel suspension layout provides maximum accuracy in defining the wheel movement during driving. The result is precise and predictable handling of the car as well as reduced body movement during braking and cornering. Double wishbone suspension systems are used in race cars.

EBD Electronic Brake-force Distribution works in tandem with ABS analysing weight distribution around the car and automatically adjusting the braking force applied to front and rear wheels to help maintain directional stability.

Electronic Throttle Control System

(ETCS or Drive-by-wire) The mechanical link from the accelerator pedal to the engine is replaced with sensors that detect the throttle position and feed instructions directly to the engine management system. This provides instant, directly proportional yet smooth responses to throttle inputs.

Ergonomics Ergonomics is the applied science of designing a working environment, in this case the car's cabin, in order to maximise the occupants comfort and safety. In simple terms, that means locating major controls and instruments in a way that makes them easy and comfortable to use and to see. This is extended to seating which minimises driver fatigue and discomfort.

Grade logic An intelligent system built into our 5-speed automatic transmissions. When the Accord is in fully automatic mode, grade logic recognises different driving styles and road conditions, then selects the optimum gear ratio for smooth, seamless driving, particularly over hilly routes and through corners.

High Intensity Discharge (HID) headlamps Instead of a bulb, the sealed HID headlamps contain xenon gas. An electric spark (arc) passing through the gas produces an even, true-white light with a higher intensity than conventional halogen units for improved visibility.

i-CTDi The Honda i-CTDi engine - the 'i' stands for 'intelligent' - is a new-generation direct injection engine that uses both the latest common rail and variable turbocharger technology. As a result, it's significantly quieter, smoother, more powerful and returns greater fuel economy than conventional diesels.

i-VTEC (Variable valve timing and lift, electronic control and VTC (Variable Timing Control) The result is an engine that adapts perfectly to your driving requirements, delivering power exactly when you need it, but with remarkable fuel efficiency.

Lane Keeping Assist System (LKAS) identifies the boundaries of the vehicle's lane by processing images from a C-MOS camera mounted behind the windscreen. It then calculates the optimum steering torque to keep the vehicle in the centre of the lane and provides steering torque to the wheel to keep the vehicle in the centre of the lane. A continuous beep sound will be emitted when the vehicle is about to cross the lane markings.

Lane Keeping Assist System operates when the following conditions are fully fulfilled:

- on roads with left and right lane boundary markings (where markings are clear and visible)
- on motorways or roads that are equivalent to motorways
- driver has to keep contact with the steering wheel; if the system fails to recognise the driver's input on the steering, it switches itself off
- side indicators are not activated
- steering torque generated by the driver does not indicate imminent lane change manoeuvre

Torque Torque is a twisting or rotational force. For example, when you use a spanner to tighten a bolt, you are actually applying torque to turn the bolt. The further out you hold the spanner, the more torque you apply. Low rev torque is the ability of an engine to develop strong response (rotational force), and hence, acceleration from lower revs and speeds. As speed rises, torque becomes less important than power for maintaining high speeds. Power: Power is a measurement of how fast work can be done.

VTC (Variable Timing Control) Changes the timing angle of the intake side camshaft relative to the crankshaft as engine speed and load change. This way the cylinder filling with air/fuel mixture is optimised for improved torque and performance, with 90% of torque available at just 3,000 rpm.

VTEC (Variable Valve Timing and Lift Electronic Control) Varies the amount of valve lift and the duration of valve opening during the intake stroke of each engine cylinder. The effect is optimised combustion over changing engine speeds with the result of reduced fuel consumption and emissions as well as increased engine performance.

Variable turbocharger Turbochargers use rotors to pressurise the air going into the cylinders. This increases the air's oxygen density, improving combustion and producing more power. The turbocharger fitted to the i-CTDi engine has variable nozzles, which boost the airflow according to how hard you press the accelerator - the more you put your foot down, the more the airflow is increased. This produces instant, smooth acceleration, virtually eliminating the problem of 'turbo lag'.



Why do we find it hard to talk about money?

You've studied it. Talked about it. Dreamed about it. Now you have to pay for it. Just doesn't feel like part of the fun, somehow. So we thought, there should be a better way to do this. Not a quick-fix, easy-terms, one-size-fits-all deal, either. Finance that sounds too good to be true usually is. We were thinking 'simple', 'flexible' and 'convenient'. And that's what you get, right from making the deposit.

So where do we start?

With the deposit. Your current car or cash are both fine. You don't have either? No problem: we can work out a zero-deposit package, too.

Done your sums?

The most important part of any finance is the monthly payments. Only you know how much you can really afford. So tell us. That way, we can work out monthly payments to fit in with your budget. Our finance packages are flexible enough to work round just about anything. After that, it's up to you.

We give you choices right through the process. Including at the end of the agreement. You want to keep the car? Simple: make the final payment and it's all yours. Or, you can give it back. As long as it's in good condition and within the agreed mileage, you can walk away with nothing more to pay*.

And if you're ready for a new Honda, we'll arrange a part exchange and a new finance package. Easy, really.

Making our finance more straightforward meant leaving out a few things.

The long, complex forms.

The dense technical jargon.

The wait to see if you've got the go-ahead.

We didn't think you'd miss them.

We don't. All of which means you get your new Honda quicker.

Of course, none of this is any substitute for talking it over with your local Honda dealer.

So now you know what to expect from a visit to us. When can we expect a visit from you?



Terms and Conditions

*Honda Aspirations only (Honda's PCP product).

Credit provided by Honda Finance Europe Plc. 470 London Road, Slough, Berkshire, SL3 8QY.



Want to predict the future?

The Accord, like all Hondas, is made to our exacting standards. But we take nothing for granted. So the Accord is covered by a 3 year manufacturer's warranty*. You can extend this period of cover with a Hondacare Guarantee and give yourself peace of mind for up to a further 3 years.

Hondacare Guarantee is unique and only available from authorised Honda Dealerships. Just choose the period of cover you want - from 1 to 3 years. Then sit back and relax, knowing that help is only a telephone call away. Unexpected repair bills will be settled immediately.

Further benefits include:

- Repairs carried out by Honda trained technicians.
- Guarantees the use of only Genuine Honda parts.
- Hondacare Assistance - Honda's comprehensive breakdown and recovery package.

Just ask your authorised Honda Dealership for more details.

Like beneficial insurance rates?

The Honda Owners Insurance scheme has been specially designed so that Honda owners receive beneficial insurance cover at competitive rates. To obtain details of all the benefits included and to receive a quotation, please contact your authorised Honda dealer or call 0845 200 8000.

Is help at hand when it really matters?

With Honda it is. Because if you're unlucky enough to have an accident, we have a free Hondacare Accident Helpline that will sort all the details for you and make it a priority to get your car back on the road. In the event of an accident please telephone 0800 521 728.

12,500 Miles / 12 Months	
Jazz • Stream • FR-V • CR-V (Petrol and Diesel) Civic Hybrid • Civic Type-R Civic (Petrol and Diesel) Accord Saloon and Tourer (Petrol and Diesel)	
Months	Miles
12	12,500
24	25,000
36	37,500
48	50,000
60	62,500
72	75,000
84	87,500
96	100,000
108	112,500
120	125,000
132	137,500
144 [†]	150,000

[†]Should mileage exceed 144 months or 108,000/150,000 miles, please contact your local Honda dealer to obtain a Continuation Service book.

Can your car get the service you do?

We spend a lot of time working out the best service we can give to our customers.

And you'd expect us to also come up with the best service for your car, too. So we designed Hondacare Budget Plan Servicing**. This way, you can spread the cost of servicing your car with fixed monthly payments. It's available for new and used Honda cars, and for private and business users too.

* Subject to the warranty terms and conditions listed on pages 15 and 16 of your service book.

** Terms and conditions apply.

Accord	Transmission	CO ₂ (g/km)	VED Band	Fuel economy combined (l/100km/mpg)
2.0 i-VTEC SE	5MT	176	E	7.4/38.2
2.0 i-VTEC SE	5AT	189	E	8.0/35.3
2.0 i-VTEC Type-S	5MT	189	F	8.0/35.3
2.0 i-VTEC Type-S	5AT	200	F	8.4/33.6
2.0 i-VTEC EX	5MT	189	E	7.7/36.7
2.0 i-VTEC EX	5AT	200	F	7.7/35.3
2.2 i-CTDi Sport	6MT	145	F	5.5/51.4
2.2 i-CTDi EX	6MT	145	C	5.5/51.4
2.4 i-VTEC Type-S	6MT	214	F	9.0/31.4
2.4 i-VTEC EX	6MT	214	F	9.0/31.4
2.4 i-VTEC EX	5AT	223	F	9.4/30.1
2.4 i-VTEC EX with ADAS	5AT	218	F	9.2/30.7



Ever tried a little blue sky thinking?

We love this planet as much as you do. And we're well aware that a global corporation that builds cars has to take its responsibilities very seriously. And that's why we only ever build cars with the future in mind. A lot of damage has been done since the invention of the internal combustion engine, but thanks to cutting-edge technology we're aiming to cut it out altogether.

Our manufacturing plant in Swindon is reducing the amount of landfill waste it produces. At the going rate, we're on track to cut that figure to zero by 2010. The development of our 3R concept - reduce, reuse, recycle - allows us not only to apply our principles throughout the plant, but also provides an educational tool for local schools and councils who visit us on a regular basis.

We've made technological developments that radically reduce emissions too. Like the Insight. It's the most fuel-efficient sports coupé in existence thanks to its Integrated Motor Assist technology. The same technology you'll find in the Civic Hybrid, winner of Best Fuel Economy in 2003 and Best 1-1.4 litre Engine at the 2004 International Engine of the Year 2003 Awards and the BP Green Fleet award for vehicle innovation and Car Manufacturer of the year 2005. Our new generation i-series engines, such as our i-VTEC engine, have been on course since 1995 to produce 75% less HC (hydrogen and carbon atoms) and NOx (oxides of nitrogen) emissions by 2005.

Ahead of new regulations due to come into force in 2006, we've reduced our motorcycles' emissions and fuel consumption by 30%. And the production of road-going two-stroke engines is now a thing of the past. Even when it comes to boats, if you're after an outboard engine, with Honda you'll only ever get the cleaner four-stroke version.

At Honda, if we have an idea, we want to make it happen. Take the groundbreaking FCX fuel-cell electric vehicle, which produces only water as a by-product. The first car of its kind to obtain approval for commercialisation in the US, it's fuelled by the chemical reaction between hydrogen and oxygen - we've even built a solar-powered hydrogen fuelling station at our research institute in Los Angeles. It's the greenest vehicle on the planet, and it's already driving around the streets of Tokyo and LA.

Not only are we cutting environmentally damaging emissions, we're actively putting something back in. In association with The CarbonNeutral Company we are promoting projects that absorb, neutralise and offset the carbon dioxide emission produced by car driving. The Greener Driving Gift, offered by participating dealers to new Honda owners, neutralises CO₂ produced during the first month of driving. We are also planting forests in the UK, swapping kerosene burners for solar panels in Sri Lanka and introducing energy efficiency equipment in poorer homes across the USA. And there are more projects on the way.

We're also rewriting the rulebooks by changing the way people think about transport. We know that cars have become so popular that the planet is becoming gridlocked. That's why we've introduced traffic-reduction schemes in Singapore, such as the Intelligent Community Vehicle System, which encourages shared use of vehicles in urban areas. We want to create more public space, reduce traffic, lower pollution and provide an improved living environment for everyone.

At Honda we want to fill the world with great ideas. Not pollution.



Honda Insight - First in the Sports/Coupé category of the Environmental Transport Association's Car Buyers guide 2002



Honda - 2005 Winner of Car Manufacturer of the Year



Why stop when you reach the limit?

Think of some of the world's most innovative creations. The people who made them dared to challenge convention. At Honda, we let nothing get in the way of a good idea. We encourage our designers to test the boundaries of science as well as their own imaginations. That's why our cars, motorcycles, ATV's, powerboat engines and power equipment products are used the world over, consistently winning new awards, new accolades and new friends.

But it doesn't stop there. After witnessing an aerobatics display as a schoolboy our founder, Soichiro Honda, dreamed of creating an aeroplane. Eighty-seven years later our engineers are putting the finishing touches to the HondaJet. True to Honda's belief in finding solutions through innovation and imagination, the jet challenges standard aircraft design. Its HF118 turbofan engines are located on the upper sides of the wings, part of a groundbreaking design that reduces drag at high speed and increases fuel efficiency by 40%. This break from conventional design also allows for 30% more cabin space. It goes to show what you can achieve by letting your imagination run free.

On the ground our desire to innovate is as strong as it's ever been. This applies as much to bicycles as it does to Formula-1 racing cars. On two wheels, we have recently perfected the RN01 downhill mountain bike, with its unique gearbox system that allows cyclists to change gear without the need to pedal. This revolutionary design was born out of an enthusiastic idea that was allowed to flourish, rather than a design requirement.

On the track, our Formula-1 programme saw young British contender Jenson Button rise to the podium ten times in 2004, the Honda BAR Team achieving second place in the Constructor's Championship, the Honda engines proving credible and consistent rivalry to those of the dominant Ferrari team.

Some innovations come from the heart. One Honda engineer, who hated diesel engines so much, made it his mission to revolutionise them. The i-CTDi, winner of the

International Engine of the Year Awards 2005 for the 2-litre to 2.5-litre category, sets a new benchmark in diesel technology. High in torque and low in fuel consumption, it's unique closed deck aluminium construction, one of the only aluminium diesel engines on the market, offers power, cleanliness and an incredibly low noise output, creating a level of performance that rivals the very best in the market. It's part of our constant mission to reduce emissions and create cleaner vehicles – like the FCX series. These vehicles use hydrogen fuel cells as their power source, producing only water as a by-product. When it comes to engines, you don't get much cleaner than that.

And then there's ASIMO. Our famous robot. With his ground breaking abilities in balance, manoeuvrability, face and voice recognition, he represents our vision of creating technologies that go way beyond our everyday perceptions of transport and mobility.

Our latest inspiration comes in the form of an intelligent night-vision system, which uses infrared cameras to see in the dark and is the world's first system to detect pedestrians or moving, heat-emitting objects such as animals that are in the vehicles path, or even judged to be moving into that path. The system warns the driver via an audio caution linked to a 'heads-up' display above the dashboard.

Even when it comes to safety we look beyond the expected. As one of the first manufacturers to develop pedestrian safety technology, we continue to place importance in this area. Our latest innovation is the 'pop-up' bonnet system. It uses sensors in the bumper to indicate whether an impact with a pedestrian has occurred. This triggers a mechanism that raises the rear portion of the engine hood away from the hard components found underneath it. Our Head Injury Criteria are reduced by up to 40% when this system is fitted.

All these innovations are in constant development, and there are new ideas being born every minute. We are always looking to improve, to make our products cleaner, safer, more efficient. It's all part of our continuing mission to push back the boundaries of science, to turn inspirational ideas into reality.



Designer colours. Every aspect of the new Accord has been designed to combine innovation and style. But the most important designer input we leave to you - the choice of colour. It's a more difficult choice than it may sound. There are no fewer than nine stunning colours in both metallic and pearl finishes.

Colour options for your

ACCORD

Alabaster Silver Metallic

Blueish Silver Metallic

Graphite Pearl

Nighthawk Black Pearl

Dark Mocha Pearl

Royal Blue Pearl

Arctic Blue Pearl

Milano Red

*Deep Green Pearl**

Colour options for your

ACCORD

Graphite Pearl

	Black fabric	Sports upholstery	Black leather	Ivory leather
2.0 i-VTEC SE	●	-	-	-
2.0 i-VTEC Type-S	-	●	-	-
2.0 i-VTEC EX	-	-	●	○
2.2 i-CTDi Sport	-	●	-	-
2.2 i-CTDi EX	-	-	●	○
2.4 i-VTEC Type-S	-	●	-	-
2.4 i-VTEC EX	-	-	●	○

● standard - not available ○ optional

Accord Saloon Colour and Trim

Dark Mocha Pearl

	Black fabric	Sports upholstery	Black leather	Ivory leather
2.0 i-VTEC SE	●	-	-	-
2.0 i-VTEC Type-S	-	●	-	-
2.0 i-VTEC EX	-	-	●	○
2.2 i-CTDi Sport	-	●	-	-
2.2 i-CTDi EX	-	-	●	○
2.4 i-VTEC Type-S	-	●	-	-
2.4 i-VTEC EX	-	-	●	○

● standard - not available ○ optional

Accord Saloon Colour and Trim

Arctic Blue Pearl

	Black fabric	Sports upholstery	Black leather	Ivory leather
2.0 i-VTEC SE	●	-	-	-
2.0 i-VTEC Type-S	-	●	-	-
2.0 i-VTEC EX	-	-	●	○
2.2 i-CTDi Sport	-	●	-	-
2.2 i-CTDi EX	-	-	●	○
2.4 i-VTEC Type-S	-	●	-	-
2.4 i-VTEC EX	-	-	●	○

● standard - not available ○ optional

Accord Saloon Colour and Trim

Deep Green Pearl*

	Black fabric	Sports upholstery	Black leather	Ivory leather
2.0 i-VTEC SE	●	-	-	-
2.0 i-VTEC Type-S	-	●	-	-
2.0 i-VTEC EX	-	-	●	○
2.2 i-CTDi Sport	-	●	-	-
2.2 i-CTDi EX	-	-	●	○
2.4 i-VTEC Type-S	-	●	-	-
2.4 i-VTEC EX	-	-	●	○

● standard - not available ○ optional

Accord Saloon Colour and Trim

* Special order only

Alabaster Silver Metallic

	Black fabric	Sports upholstery	Black leather	Ivory leather
2.0 i-VTEC SE	●	-	-	-
2.0 i-VTEC Type-S	-	●	-	-
2.0 i-VTEC EX	-	-	●	-
2.2 i-CTDi Sport	-	●	-	-
2.2 i-CTDi EX	-	-	●	-
2.4 i-VTEC Type-S	-	●	-	-
2.4 i-VTEC EX	-	-	●	-

● standard - not available ○ optional

Accord Saloon Colour and Trim

Blueish Silver Metallic

	Black fabric	Sports upholstery	Black leather	Ivory leather
2.0 i-VTEC SE	●	-	-	-
2.0 i-VTEC Type-S	-	●	-	-
2.0 i-VTEC EX	-	-	●	-
2.2 i-CTDi Sport	-	●	-	-
2.2 i-CTDi EX	-	-	●	-
2.4 i-VTEC Type-S	-	●	-	-
2.4 i-VTEC EX	-	-	●	-

● standard - not available ○ optional

Accord Saloon Colour and Trim

Nighthawk Black Pearl

	Black fabric	Sports upholstery	Black leather	Ivory leather
2.0 i-VTEC SE	●	-	-	-
2.0 i-VTEC Type-S	-	●	-	-
2.0 i-VTEC EX	-	-	●	○
2.2 i-CTDi Sport	-	●	-	-
2.2 i-CTDi EX	-	-	●	○
2.4 i-VTEC Type-S	-	●	-	-
2.4 i-VTEC EX	-	-	●	○

● standard - not available ○ optional

Accord Saloon Colour and Trim

Royal Blue Pearl

	Black fabric	Sports upholstery	Black leather	Ivory leather
2.0 i-VTEC SE	●	-	-	-
2.0 i-VTEC Type-S	-	●	-	-
2.0 i-VTEC EX	-	-	●	○
2.2 i-CTDi Sport	-	●	-	-
2.2 i-CTDi EX	-	-	●	○
2.4 i-VTEC Type-S	-	●	-	-
2.4 i-VTEC EX	-	-	●	○

● standard - not available ○ optional

Accord Saloon Colour and Trim

Milano Red

	Black fabric	Sports upholstery	Black leather	Ivory leather
2.0 i-VTEC SE	●	-	-	-
2.0 i-VTEC Type-S	-	●	-	-
2.0 i-VTEC EX	-	-	●	-
2.2 i-CTDi Sport	-	●	-	-
2.2 i-CTDi EX	-	-	●	-
2.4 i-VTEC Type-S	-	●	-	-
2.4 i-VTEC EX	-	-	●	-

● standard - not available ○ optional

Accord Saloon Colour and Trim



These specification details do not apply to any particular product which is supplied or offered for sale. The manufacturers reserve the right to vary their specifications, including colours, with or without notice and at such times in such manner as they think fit. Major as well as minor changes may be involved. Every effort, however, is made to ensure the accuracy of the particulars contained in this brochure. This publication shall not constitute in any circumstances whatsoever an offer by the Company to any person. All sales are made by the Distributor or Dealer concerned subject to and with the benefit of the standard Conditions of Sale and Warranty given by the Distributor or Dealer, copies of which may be obtained from him on request. This publicity material applies to the UK only Trade Descriptions Act (1968). Whilst efforts are made to ensure specification accuracy, brochures are prepared and printed several months in advance of distribution and consequently cannot always immediately reflect either changes in specification or in some isolated cases the provision of a particular feature. Customers are always advised to discuss specification details with the supplying Dealer especially if your model selection is dependent upon one of the features advertised.

Honda (UK) - Cars

470 London Road, Slough, Berkshire, SL3 8QY
Honda Contact Centre - Telephone: 0845 200 8000
www.honda.co.uk



Printed on Recycled Paper