

1989 FORD BRONCO II



FORD BRONCO II FOR 1989

Bronco II for 1989 has a new front-end design that is contemporary in style and more aerodynamic in function. And inside, a new ergonomic instrument panel has been fashioned out of a design philosophy that is sharply focused on the needs of the driver.

No less advanced is Bronco II's performance. Bronco II is powered by a high-torque 2.9L V-6 equipped with a computer-controlled multi-port electronic fuel-injection system. A computerized anti-lock rear brake system is standard, too.

Bronco II also features power-assisted steering comfort, plus the excellent ride and handling balance of Ford's unique Twin-I-Beam (2WD) or Twin-Traction Beam (4WD) independent front suspension.

Bronco II 4-wheeling fun is yours with manual locking hubs and transfer case. Or enjoy the convenience of automatic locking hubs with the optional Touch-Drive electric shift transfer case.

BEST-BUILT AMERICAN TRUCKS EIGHT YEARS RUNNING

For the past eight consecutive years, Ford quality has led all other American automotive companies. This is based on an average of owner-reported problems in a series of surveys of '81-'88 models designed and built in North America.

Right: Eddie Bauer Bronco II in two-tone Cabernet Red and Light Sandalwood Clearcoat Metallic. Some equipment shown is optional.





FORD EDDIE BAUER BRONCO II

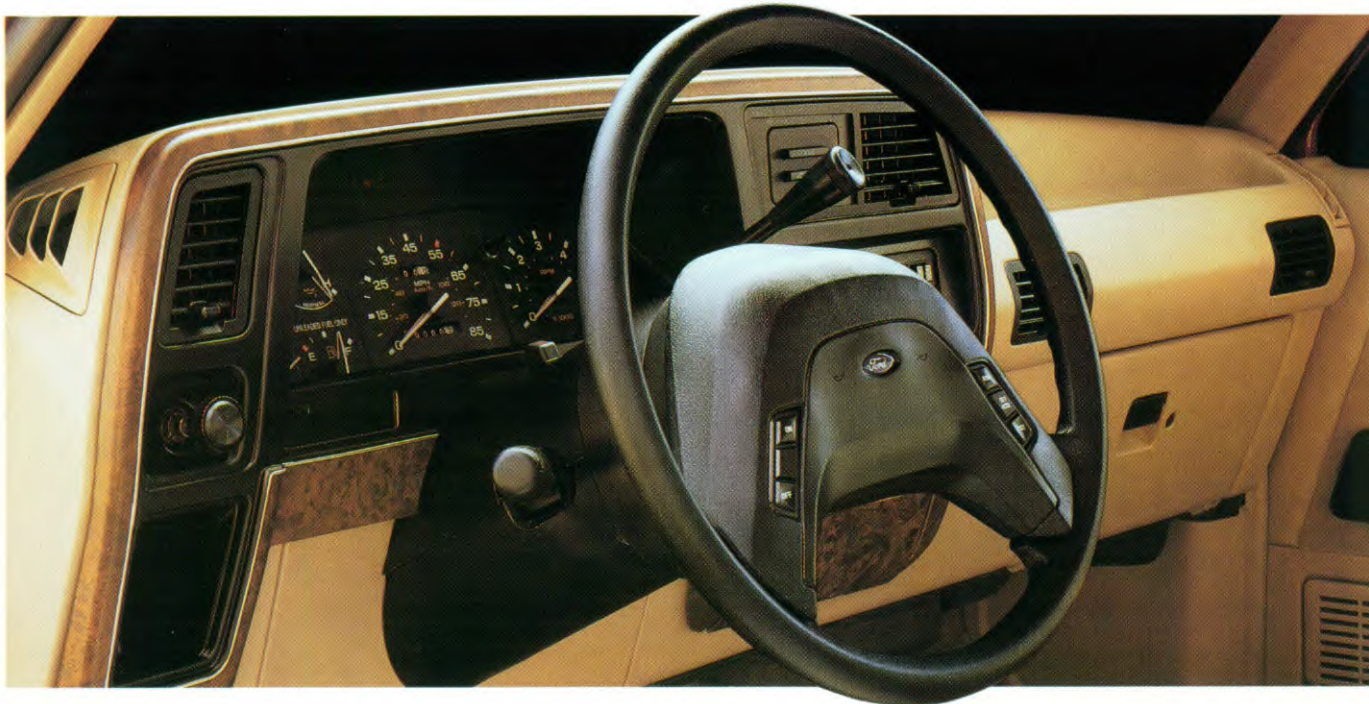

Left: Bronco II for 1989 features a new ergonomic instrument panel designed for excellent driving convenience. The shift lever for the optional automatic transmission is now positioned on the steering column.

The Ford Eddie Bauer Bronco II is named after the world-famous designer of high-quality outdoor gear and leisure wear. The Eddie Bauer model is handsomely appointed and offers the combination of truck-type toughness and car-like qualities designed into every Ford Bronco II.

THE EDDIE BAUER SIGNATURE

Eddie Bauer, the featured vehicle on pages 2-3 showcasing Bronco II's new aero front-end design, is distinguished by its unique two-tone paint treatment with dual accent stripes.

Standard also are the P205 outlined white letter all-season radials, sporty cast aluminum wheels, Privacy™ glass rear quarter windows, bright low-mount western swingaway mir-

rors, and outside swingaway spare tire carrier with cover.

Inside, Eddie Bauer features premium cloth reclining Captain's Chairs with power lumbar supports. The sound system is an electronic premium AM/FM stereo radio with cassette tape player, digital clock and four speakers.

You also get speed control and adjustable tilt steering wheel; rear window wiper/washer and defroster; an Eddie Bauer two-piece luggage set shipped directly from Eddie Bauer; plus all the features of the superbly equipped Bronco II XLT, including air conditioning.

"FORD CARE" PROTECTION —
AN EDDIE BAUER EXTRA

Eddie Bauer Bronco II comes with the "Ford Care" extended maintenance and limited war-

ranty program. It provides coverage up to 24 months or 24,000 miles — all in addition to Ford's 6-year/60,000-mile powertrain warranty.

Ask your Ford Dealer to give you the full details of this limited warranty and to show you up close everything that puts the Eddie Bauer Bronco II in a class by itself.

Right: Bronco II comes with versatile 50/50 split-folding rear seats.

Below: Controls for the optional Touch-Drive electric shift transfer case (4WD) are located on the new ergonomic instrument panel.



Right: Eddie Bauer premium cloth reclining Captain's Chairs with console in Light Sandalwood.

Some equipment shown on these pages is optional.





FORD BRONCO II XLT

The Bronco II XLT nameplate represents Ford's commitment to offering exceptional value in a sport utility vehicle that's superbly equipped inside and out.

XLT comes with the features most drivers prefer, including the following which are in addition to those of the Bronco II XL model featured on pages 8-9.

XLT COMFORT AND CONVENIENCE

Bronco II XLT provides the comfort of air conditioning in its impressive list of features. A tachometer is included along with the standard analog gauges in Bronco II's new ergonomic instrument panel. And the steering wheel is wrapped in leather.

The reclining front Captain's Chairs and the 50/50 split-

folding rear seats are trimmed in cloth. If you want a 5-passenger Bronco II XLT, choose the optional 60/40 cloth split bench front seat.

XLT's luxury-level door trim has carpeting on the lower section plus a map pocket for carrying an assortment of travel items. Also standard in XLT is a helpful headlamps-on reminder chime.

XLT EXTERIOR STYLE

XLT's handsome exterior features deluxe wheel trim, bright grille insert and headlamp frames, plus lower protective bodyside moldings.

To dress up your XLT even more, add the optional deluxe two-tone paint treatment, or either the deluxe or sport tape striping. Another option is the youthful Sport Appearance Package shown and described on the following pages as part of the Bronco II XL Sport model.

Right: Bronco II XLT in deluxe two-tone Twilight Blue Clearcoat Metallic and Silver Clearcoat Metallic. Shown is optional Preferred Equipment Package 931A (XLT Plus), which includes the deluxe two-tone paint among its many features.



Left: Bronco II XLT interior with 60/40 cloth split bench seat in Crystal Blue. The shift lever for the optional automatic transmission is now positioned on the steering column.

Some equipment shown on these pages is optional.





B R O N C O II

FORD BRONCO II XL AND XL SPORT



Bronco II offers you a choice of two XL models. Both are well equipped, inside and out. And they're powered by a standard 2.9L EFI V-6 that heads a list of superb engineering features.

BRONCO II XL

Bronco II XL includes knitted vinyl reclining front bucket seats with tip-slide feature for easy rear seat access. The 50/50 split rear seats let you fold down either one or both seat backs when you need additional cargo space — up to a maximum 56.9 cu. ft.

In the new driver-oriented instrument pod are analog gauges for engine temperature, oil pressure and voltmeter. A trip odometer is included, too. Controls for the turn signals, windshield wipers and washer, headlamp high-beams and flash-to-pass feature are on a single steering column-mounted lever.

The new fiberglass cloth-covered headliner looks great and provides plenty of headroom. And a floor-mounted heater vent has been added for the comfort of the rear passengers.

Bronco II XL also comes with an electronic AM/FM stereo radio with four speakers, variable-speed interval windshield wipers, tinted glass, black fold-away mirrors, and sport wheel covers.

BRONCO II XL SPORT

This exciting XL features the Sport Appearance Package. Included are a brush/grille guard, fog lamps, protective wheel spats, black wraparound front

bumper, and black tubular rear bumper with stone deflector.

But that's not all. XL Sport comes with its own two-tone paint treatment. Deep-dish cast aluminum wheels, flip-open rear window, tachometer, and headlamps-on reminder chime are standard as well.

The way it's styled and equipped, XL Sport captures in a special way the youthful spirit of fun-to-drive performance engineered into Bronco II.



Bronco II XL interior with knitted vinyl reclining bucket seats in Medium Grey.

Some equipment shown on these pages is optional.

Bronco II XL Sport in two-tone Raven Black and Silver Clearcoat Metallic.

FORD BRONCO II ENGINEERING

Bronco II is an all-purpose vehicle with the power, ride quality, handling and maneuverability to satisfy the variety of personal uses for which it is designed.

FUEL-INJECTED V-6 POWER AND TORQUE

The 2.9L multi-port electronically fuel-injected V-6 delivers 140 horsepower at 4600 rpm. It has a flat torque curve that generates 80 percent of torque at only 1600 rpm and reaches its peak 170 lbs.-ft. at 2600 rpm. That's plenty of muscle for responsive on- or off-road performance.

The multi-port electronic fuel-injection (EFI) system is engineered for precise fuel metering, easy starting in hot or cold weather, and smooth running. This EFI system is governed by Ford's advanced EEC-IV engine control computer.

EEC-IV gathers and processes information on a broad range of conditions affecting the engine's overall performance. The computer then controls the fuel-air mixture and adjusts the spark timing to optimize performance and efficiency.

MANUAL OR AUTOMATIC OVERDRIVE TRANSMISSION

The 2.9L comes with a standard 5-speed manual transmission. It has close-ratio gearing and is synchronized in all gears — including reverse, an especially helpful feature for off-road travel.

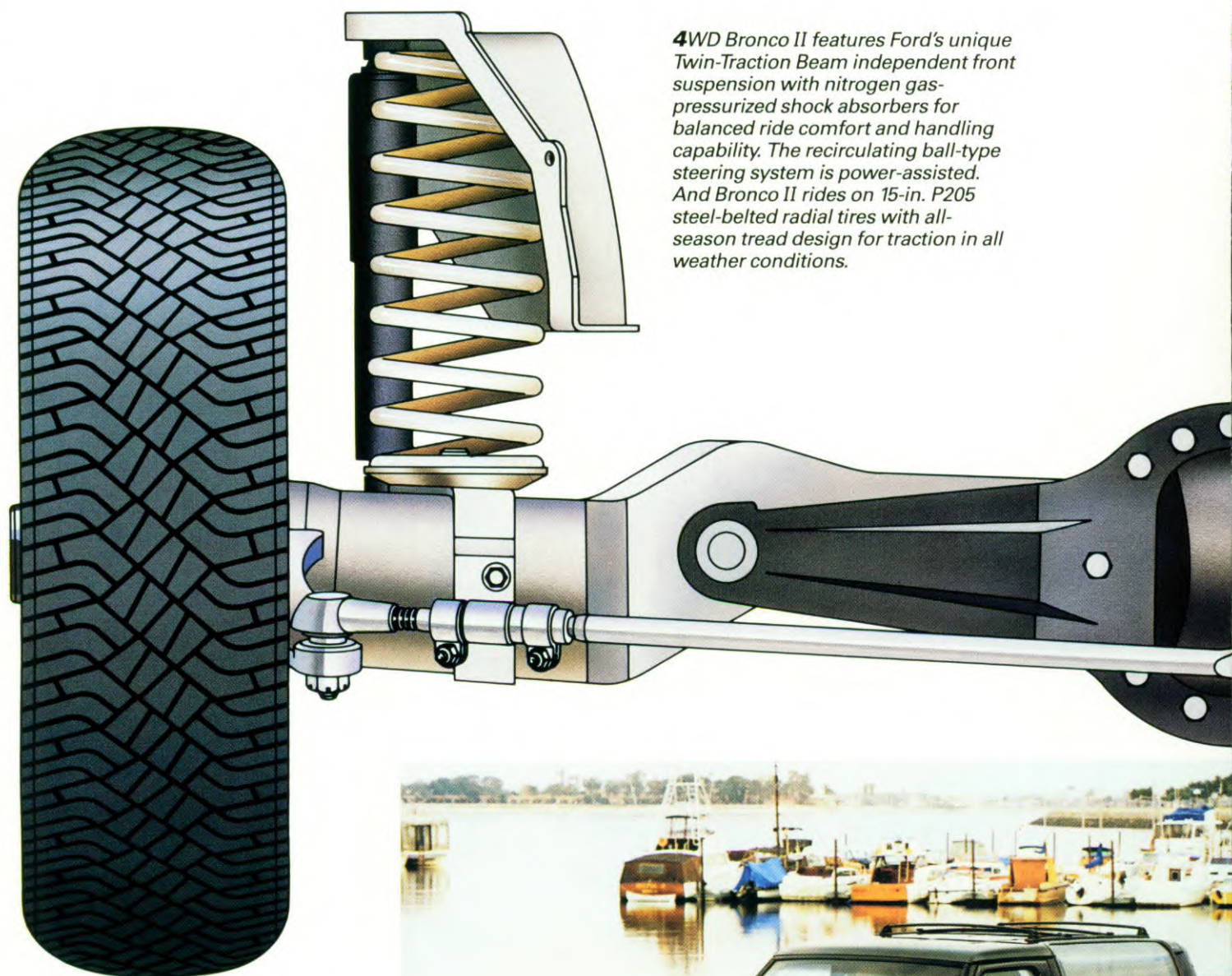

4WD Bronco II features Ford's unique Twin-Traction Beam independent front suspension with nitrogen gas-pressurized shock absorbers for balanced ride comfort and handling capability. The recirculating ball-type steering system is power-assisted. And Bronco II rides on 15-in. P205 steel-belted radial tires with all-season tread design for traction in all weather conditions.



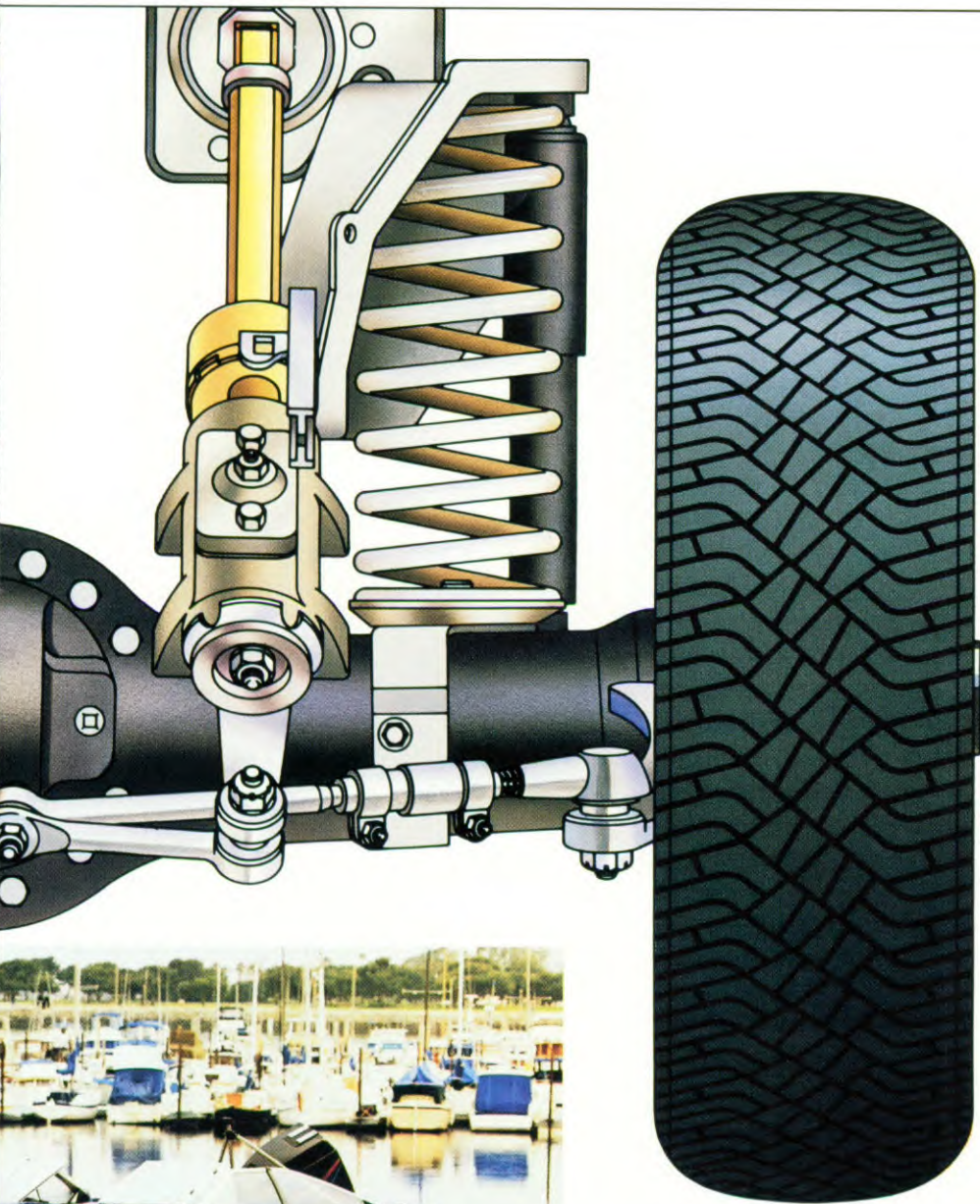

The V-6-powered Bronco II has a maximum trailer weight rating of 5,000 pounds in the 2WD model; 4,900 pounds in the 4WD model (reduced by passenger and cargo weight in the towing vehicle). For this kind of towing, a properly equipped Bronco II should have the optional 4-speed automatic overdrive transmission, 4.10 limited-slip rear axle, and the super engine cooling package.

The optional 4-speed automatic overdrive transmission (A4LD) with electronic converter clutch engages during steady-speed operation in fourth gear and the upper range of third gear. This eliminates power-wasting hydraulic slippage.

FORD-ENGINEERED RIDE AND HANDLING

Bronco II is engineered with Ford's unique Twin-I-Beam independent front suspension in the 2-wheel-drive model and the Twin-Traction Beam system in the 4-wheel-drive model.

With Twin-I-Beam and Twin-Traction Beam, each front wheel has its own solid axle and hefty coil spring. So each wheel can negotiate rough road conditions individually, cushioning the ride and delivering exceptional handling.

All Bronco II models are equipped with nitrogen gas-pressurized shock absorbers. They are designed to help maintain proper hydraulic fluid pressure, even over a rapid succession of bumps.

Also standard are front and rear stabilizer bars for added handling control. And for year-round traction, Bronco II rides on 15-in. P205 steel-belted radial tires with all-season tread design.

SOPHISTICATED ANTI-LOCK REAR BRAKE SYSTEM

Bronco II is equipped with an anti-lock rear brake system that is designed to inhibit rear wheel lockup under most operating conditions. Sensors monitor vehicle speed during

braking. When wheel lockup is about to occur, the system's computer processes the signals from the sensors.

The pressure control valve then modulates the rear brake line hydraulic pressure. The brakes are applied and released repeatedly at a rate of speed exceeding human capability, helping the driver maintain steering control.

The anti-lock rear brake system operates in 2WD Bronco IIs and in 4WD models running in the 2-wheel-drive mode.

FOR THE OFF-ROAD OR ON-THE-STREET 4-WHEELING ENTHUSIAST...

Bronco II offers you a choice. Go with the free-running manual locking front hubs with part-time 2-speed-shift transfer case. This system lets you shift-on-the-fly from 2WD-High to 4WD-High and back when the hubs are locked.

For the ultimate in 4-wheeling convenience, choose the optional Touch-Drive electric shift transfer case for shift-on-the-fly capability from 2WD-High to 4WD-High and back at the touch of a button at any speed.

With Touch-Drive, you need not leave the driver's seat to lock the front hubs. They lock automatically. And they engage instantly because Touch-Drive utilizes Ford's innovative electromagnetic clutch that spins up the front drive system from zero to driving speed in milliseconds.

PREFERRED EQUIPMENT PACKAGES, SPECIAL VALUE PACKAGES AND OPTIONS

Preferred Equipment Packages are groups of popular features. Simply select the package that includes the equipment you want.

Preferred Equipment Packages 922A, 923A, 931A and 934A offer special savings. Compared with the manufacturer's

suggested retail price for the items purchased individually, package discounts are the equivalent of getting certain equipment at no extra cost.

Package 923A, for example, offers a discount equivalent to getting air conditioning at no extra cost. Packages 931A and 934A offer no-extra-cost air conditioning, too, and more.

Special savings are also offered on XL, XL Sport and XLT with the 5-speed manual transmission. The features in these Special Value Packages are in addition to the items in the Preferred Equipment Packages.

Preferred Equipment Packages are subject to change. See your Ford Dealer for the latest information.

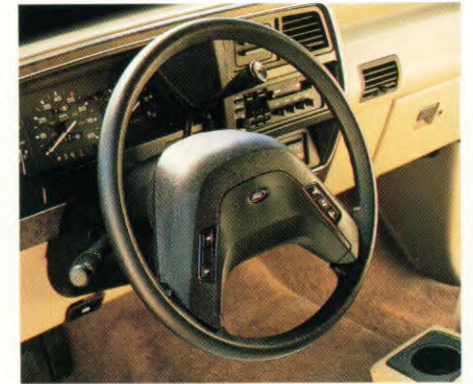

Speed control and tilt steering wheel.



Electronic AM/FM stereo radio with cassette tape player and digital clock (above) and air conditioning (below).



Bronco II XLT in Raven Black with optional silver sport tape stripe.



5-spoke cast aluminum wheels; deep-dish cast aluminum wheels.

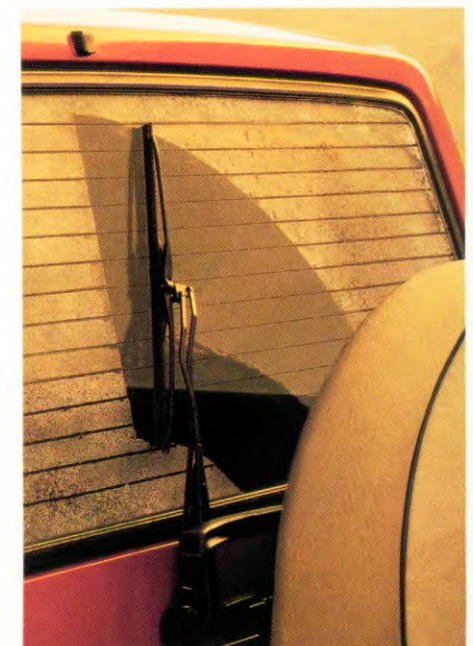

Rear window wiper/washer/defroster.

STANDARD EQUIPMENT (all models)

- 2.9L multi-port fuel-injected V-6
- 5-speed manual overdrive transmission
- Power brakes with anti-lock rear system
- Twin-I-Beam independent front suspension (2WD)
- Twin-Traction Beam independent front suspension (4WD)
- Nitrogen gas-pressurized shock absorbers
- Front and rear stabilizer bars
- Aero-design halogen headlamps
- Tinted windshield and side windows
- Front seat back recliners
- 50/50 rear split bench seats
- Electronic AM/FM stereo radio
- Ergonomic instrument cluster with fuel, engine temperature, oil pressure and voltmeter gauges; trip odometer
- Stalk-mounted controls for turn signals, constant-speed and interval windshield wipers/washer, high-beams, flash-to-pass feature

PREFERRED EQUIPMENT PACKAGES

X = Included in Package 0 = Separate Option

	Eddie Bauer 934A	XLT Plus 931A	XLT 923A	XL Sport 922A	XL 920A
Interior Features					
Air conditioning	X	X	X	0	0
Electronic AM/FM stereo with digital clock (may be deleted for credit in XL)		X	X	X	X
Electronic AM/FM stereo with cassette tape player and digital clock		0	0	0	
Electronic premium sound AM/FM stereo with cassette tape player and digital clock	X	0	0	0	
Knitted vinyl reclining bucket seats				X	X
Cloth reclining Captain's Chairs		X	X	0	0
Premium cloth reclining Captain's Chairs with power lumbar support	X				
Cloth reclining sport front bucket seats with power lumbar support		0	0	0	0
3-passenger cloth 60/40 front split bench seat		0	0	0	0
Black soft-feel vinyl steering wheel (leather-wrapped in XLT, Eddie Bauer)	X	X	X	X	X
Tachometer	X	X	X	X	0
Rear window wiper/washer/defroster	X	0	0	0	0
Ashtray light and headlamps-on reminder chime	X	X	X	X	0
Power window/lock group	X	X	0	0	0
Speed control/tilt steering wheel	X	X	0	0	0
Exterior Features					
Bright aero-design wraparound front bumper with rub strip	X	X	X		X
Bright rear step bumper with rub strip	X	X	X		X
Sport appearance package: brush/grille guard, fog lamps, black aero-design wraparound front bumper, wheel spats, black rear tubular bumper, rear stone deflector		0	0		
Grey-tinted liftgate and wrapover rear quarter windows	X	X	X	X	X
Privacy™ glass — rear quarter windows	X	X	0	0	0
Flip-open rear window	0	X	0	X	0
Black fold-away mirrors		X	X	X	X
Bright low-mount western swingaway mirrors	X	0	0	0	0
Sport two-tone paint (may be deleted)				X	
Deluxe two-tone paint (may be deleted)		X	0		0
Unique Eddie Bauer two-tone paint treatment plus dual bodyside accent paint stripes	X				
Deluxe tape stripe		0	0		
Sport tape stripe		0	0	0	0
Bright/black lower protective bodyside moldings			X		
Outside swingaway spare tire carrier/cargo cover	X	0	0	0	0
Luggage rack	0	0	0	0	0
Sport wheel covers					X
Deluxe wheel trim		X	X		0
Cast aluminum (deep-dish) wheels	0	0	0	X	0
5-spoke cast aluminum wheels	X	0	0	0	0
P205/75Rx15SL BSW all-season steel-belted radials		X	X	X	X
P205/75Rx15SL OWL all-season steel-belted radials	X	0	0	0	0
P205/75Rx15SL OWL all-terrain steel-belted radials (4WD)	0	0	0	0	0
Performance Features					
4-speed automatic overdrive transmission (with column-mounted shift)	0	0	0	0	0
Touch-Drive electric shift transfer case (4WD)	0	0	0	0	0
Super engine cooling	X	X	X	0	0
Engine block heater	0	0	0	0	0
Limited-slip rear axle	0	0	0	0	0

MANUAL TRANSMISSION SPECIAL VALUE PACKAGES

X = Included in Package

	XLT Plus 931A	XLT 923A	XL Sport 922A	XL 920A
P205/75Rx15SL OWL all-season tires	X	X	X	X
Electronic AM/FM stereo radio with cassette tape player and digital clock	X	X	X	X
Luggage rack	X	X	X	X
Outside swingaway spare tire carrier/cargo cover	X	X	X	X
Deluxe wheel trim				X

BRONCO II SPECIFICATIONS, DIMENSIONS, COLORS AND TRIMS

SPECIFICATIONS

Drivetrain	2WD or 4WD
Engine type	2.9 liter V-6
Induction system	Multi-port electronic fuel injection with EEC-IV electronic engine controls
Horsepower, SAE net	140 @ 4600 rpm
Torque, SAE net	170 lb.-ft. @ 2600 rpm
Transmission	Std. 5-speed manual overdrive, fully synchronized including reverse gear Opt. 4-speed automatic overdrive
Battery	72 AH; 650 CCA maintenance-free
Alternator	60 amps
Frame	Ladder-type, single channel with five crossmembers
Front suspension (2WD)	Twin-I-Beam axle, coil springs (computer-selected), gas-pressurized shocks, stabilizer bar
Front suspension (4WD)	Twin-Traction Beam axle, coil springs (computer-selected), gas-pressurized shocks, stabilizer bar
Rear suspension (2WD/4WD)	Semi floating-type rear axle (limited-slip differential optional), leaf springs, gas-pressurized shocks, stabilizer bar
4WD front hubs/transfer case	Std. free-running manual-locking hubs with part-time, 2-speed shift transfer case Opt. automatic locking hubs with Touch-Drive electric shift transfer case
Steering	Recirculating ball-type, power-assisted
Brakes	Power front discs/rear drums with computerized anti-lock rear system
Curb-to-curb turning diameter	33.2 (2WD); 32.4 (4WD)
Wheels (type/size)	5-hole disc/15" x 6.0JJ
Tires	Std. P205/75Rx15SL all-season (2WD/4WD) Opt. P205/75Rx15SL all-terrain (4WD)

DIMENSIONS

	2WD	4WD
Wheelbase	94.0"	94.0"
Overall length	161.9"	161.9"
Overhang (front/rear)	29.6"/38.2"	29.6"/38.2"
Tread (front/rear)	56.7"/56.9"	56.7"/56.9"
Overall width	68.0"	68.0"
Width between wheelhouses	41.8"	41.8"
Overall height	69.9"	70.4"
Load floor liftover height	29.3"	29.3"
Liftgate opening height	33.6"	33.6"
Axle clearance (front/rear)	—	7.3"/7.4"
Ground clearance at transfer case (unloaded)	—	9.3"
Angle of approach	25.7°	26.2°
Angle of departure (loaded)	25.2°	25.1°
Ramp breakover angle (loaded)	22.9°	20.4°
Cargo length — rear seat up	21.2"	21.2"
— rear seat down	53.5"	53.5"
Cargo volume — rear seat up	23.4	23.4
(cu. ft.) — rear seat down	56.9	56.9

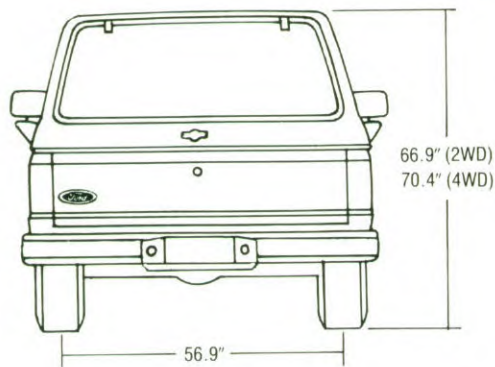
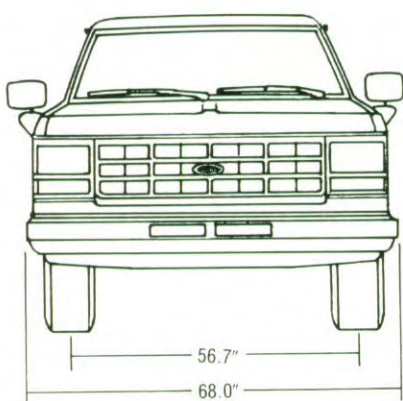

COLORS AND TRIMS

Interior Trim Colors				Exterior Colors
Medium Grey	Crystal Blue	Scarlet Red	Light Sandalwood	
X		X	X	Raven Black
X	X	X	X	Colonial White
		X	X	Scarlet Red
		X	X	Cabernet Red
			X	Light Sandalwood
			X	Light Sandalwood Clearcoat Metallic
			X	Sandalwood Clearcoat Metallic
X	X			Crystal Blue Clearcoat Metallic
X	X			Twilight Blue Clearcoat Metallic
X	X	X	X	Shadow Grey Clearcoat Metallic
X	X	X		Silver Clearcoat Metallic
Eddie Bauer Bronco II (with Light Sandalwood lower two-tone)				
			X	Raven Black
			X	Scarlet Red
			X	Cabernet Red
			X	Hunter Green Clearcoat Metallic
			X	Twilight Blue Clearcoat Metallic
			X	Sandalwood Clearcoat Metallic

DELUXE TWO-TONE PAINT

The accent color is applied to mid-bodyside/liftgate below the chamfer and above the rocker area.

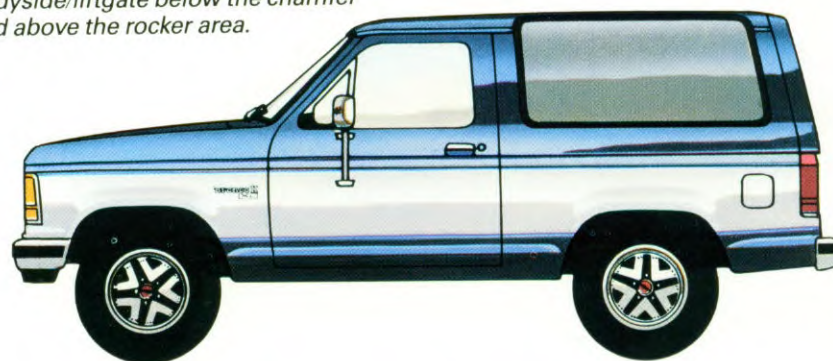

■ Body Color □ Accent Color

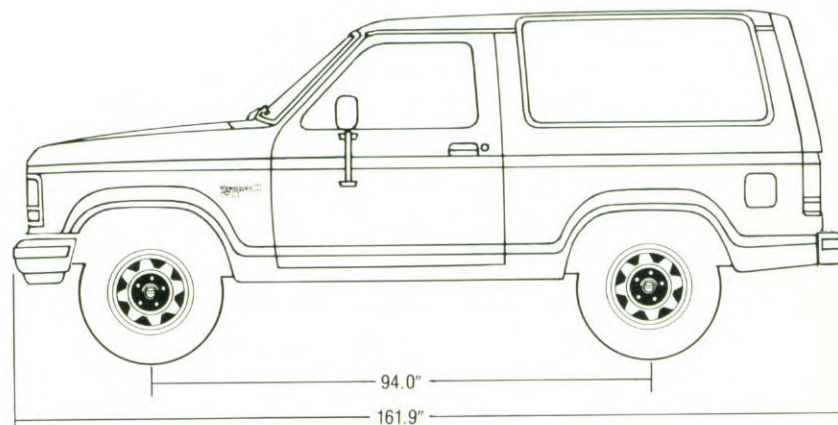

SAFETY AND OWNER BENEFITS

Ford Motor Company strongly encourages all passengers to use their safety belts. Ford urges the use of child and infant restraints. Ford's easy-to-install Tot-Guard (for children 20 to 50 pounds) is available at all Ford Dealers. If a child restraint requires a top- tether, Bronco II provides special anchorages.



FORD LIFEGUARD DESIGN SAFETY FEATURES

Vehicle operation

- Split service hydraulic brake system with warning light
- Corrosion-resistant brake lines
- Turn indicator with lane-changing signal feature
- Hazard warning flasher
- Backup lamps
- Parking lamps coupled with headlamps
- Side marker lamps
- Windshield wipers with two constant speeds plus variable intermittent speeds
- Windshield washers
- Dual outside rearview mirrors
- Glare-reduced instrument panel, windshield wiper arms and windshield pillars
- Uniform transmission shift quadrant with safety starting switch (on vehicles equipped with automatic transmission)
- Clutch or neutral starter motor interlock (on vehicles with manual transmission)
- Continuously variable control illumination intensity (instrument cluster lighting)
- Safety hood latch system
- Function-rated windshield defroster system
- Tamper-resistant (non-reversing) odometer
- Speedometer with highlighted 55-mph
- Inertia shut-off switch for electric fuel pumps

Occupant protection

- Safety-designed front end structure
- Two-position door safety latches
- Integral lap and shoulder belts with automatic retractors for front outboard occupants
- Lap belt for center front passenger (with optional 60/40 split bench seat)
- Safety belt fastening reminder warning light and buzzer or chime for the driver's seat
- Lap belts with retractors for rear seating positions
- Energy-absorbing steering column and steering wheel
- Energy-absorbing armrests and safety-

- designed door handles
- Energy-absorbing instrument panel with padding for right front passenger (also center front with optional 60/40 split bench seat)
- Energy-absorbing sun visors
- Energy-absorbing front seat back tops
- Self-locking seat back latches
- Head restraints for front outboard occupants
- Safety glove box latch
- Inside yieldaway rearview mirror
- Impact-absorbing laminated safety glass windshield
- Flame-resistant interior materials
- Safety-designed coat hook
- Safety-designed radio control knobs and push buttons

6-YEAR/60,000-MILE POWERTRAIN WARRANTY

Ford's powertrain warranty covers all new 1989 cars and light trucks for 6 years or 60,000 miles, whichever comes first. This limited warranty covers major powertrain components. Certain restrictions and deductible apply. Ask your dealer for a copy.

6-YEAR/100,000-MILE CORROSION PROTECTION

Corrosion warranty coverage for outer body panel rust-through is 6 years or 100,000 miles, whichever comes first. See your Ford Dealer for details and a copy of this limited warranty.

SCHEDULED MAINTENANCE

Here are some examples of scheduled maintenance intervals for the 1989 Bronco II. For complete maintenance recommendations, refer to the Bronco II Scheduled Maintenance Booklet.

Engine oil and filter change	each 7,500 miles or 6 months
Spark plug change	each 30,000 miles
Air filter replacement	each 30,000 miles
Engine coolant replacement	each 30,000 miles or 3 years

FUEL ECONOMY

EPA mileage estimates were not available at the time this catalog was approved for printing. As soon as EPA figures are released, your Ford Dealer will be among the first to receive this information and will be happy to pass it along to you.



Participating Ford Dealers offer the Lifetime Service Guarantee, which guarantees their customer-paid work on your Ford vehicle for as long as you own it. A covered repair is paid for once. If it ever has to be fixed again, the repairing dealer will fix it free. Ask to see this limited warranty when you visit your participating Ford Dealer.



Optional Ford Extended Service Plans cover major components on new Ford cars and trucks for longer than the vehicle's basic warranty. Your Ford Dealer has full details.



Genuine Ford and Motorcraft original equipment replacement parts meet the same high standards as those installed in production.



The leasing alternative is available to qualified lessees through your participating Ford Dealer, who can arrange financing terms or a Red Carpet Lease[®] tailored to your circumstances through Ford Credit.

Ford-paid repair programs after the warranty period

Sometimes Ford offers adjustment programs to pay all or part of the cost of certain repairs. These programs are intended to assist owners and are in addition to the warranty or to required recalls.

Technical service bulletins

All vehicles need repairs during their lifetime. Sometimes Ford issues technical service bulletins (TSBs) and easy-to-read explanations describing unusual engine or transmission conditions which

may lead to costly repairs, the recommended repairs, and new repair procedures. Often a repair now can prevent a more serious repair later.

For more information...

Ask Ford Motor Company or your Ford or Lincoln-Mercury, Scorpio, XR4Ti dealer for Ford-paid repair programs and/or TSBs relating to your vehicle.

To get copies of materials for your vehicle or the vehicle of interest to you: Call Ford toll-free at 1-800-241-3673. Alaska/Hawaii call 1-800-241-3711 and in Georgia call 1-800-282-0959.

Or write Ford at:

Ford Customer Information System
Post Office Box 95427
Atlanta, Georgia 30347

We'll need your name and address; year, make, model and vehicle identification number, as well as engine size.

Options availability

Options shown or described in this catalog are available at extra cost and may be offered only in combination with other options and subject to additional ordering requirements or limitations.

Product changes

Ford Division reserves the right to change product specifications at any time without incurring obligations.

"Ask your Ford Dealer"

Following publication of this catalog, certain changes in standard equipment, options, prices and the like, or product delays, may have occurred which would not be included in these pages. Your Ford Dealer is your best source for up-to-date information.

