



Q7





Vorsprung durch Technik.

Three words that express the very essence of Audi. Vorsprung durch Technik isn't a slogan. It's our way of seeing the world. It is the driving force behind our history of innovation that continues into the 21st century.

Indeed, many technologies that Audi pioneered remain in our cars today. Some are milestones in the history of the motorcar. From our beginnings in 1899, to the Auto Union team's Grand Prix successes in the 1930s and our more recent wins at Le Mans, we have always been at the forefront of the motor industry.

Vorsprung durch Technik makes us who we are. To see more of its influence, read on.



Q7

Audi Q7



Greatness starts, when you don't stop.

Pushing the limits always keeps you ahead in the all-new Audi Q7. Dynamism makes its mark, created by powerful, efficient TFSI engines. With up to 245kW and 440Nm. Generously designed for engine power and power delivery. Fuel consumption and emissions kept in check. High-level performance that adapts itself to your personal driving style. Thanks to the 8-speed tiptronic and Audi drive select. From efficient in 'efficiency' mode to very sporty in 'dynamic' mode. With improved cornering on fast roads. So that you can extend your lead on any road.

The epitome of quattro® - given progressive form. Powerful and striking.



quattro®. Driving confidence in every situation.

35 years of quattro. A neverending success story. And one whose next thrilling chapter is set to impress. In the new Audi Q7. With the tried and tested quattro drive. Increased traction comes as standard. For excellent driving dynamics. Permanently. Underpinned by the new Audi drive select modes, such as 'offroad'. Making impressive use of all this car has to offer.

Everything an Audi Q7 should be:
athletic, timeless, unique.



Leaving virtually no trace allows you to make your mark.

The new Audi Q7 makes its mark in many ways. Trend-setting design. Thrilling performance. Innovative technologies. And needs an exclamation mark when it comes to lightweight construction. Up to 240 kg weight reduction compared to its predecessor. Achieved through progressive ideas and an intelligent mix of materials. For even better driving dynamics, increased efficiency and CO₂ values that are exemplary in this class.

**Self-confidence has found its shape.
Now you're ready for anything.**



Seeing further will also get you further ahead.

Shedding light on the future. With Audi all-weathered LED headlights. Their crystalline shine ensures bright, homogenous illumination of the road. Clarity right down the line. Thanks to high-precision, individually controlled light-emitting diodes. Making a visible impression. LED rear lights are also standard. Plus dynamic indicators at the rear. Safety and comfort shine in a new light.



You only thought you'd seen everything.

The future of mobility is right here. It's plain to see from the driver seat. With Audi virtual cockpit. The fully digital instrument cluster with high-resolution 12.3-inch display. A host of information the driver needs clearly in sight. Razor-sharp, brilliant and rich in contrast. With MMI navigation plus with MMI touch. Additional 8.3-inch display area with the extending MMI display. Intuitive operation included. Thanks to the intelligent new MMI control concept. Fewer buttons, more functions. Vehicle settings, navigation, telephone, Audi connect and media. An even larger touchpad for even easier operation. Using the complex technology then becomes child's play. So you can relax and focus on discovering new destinations.



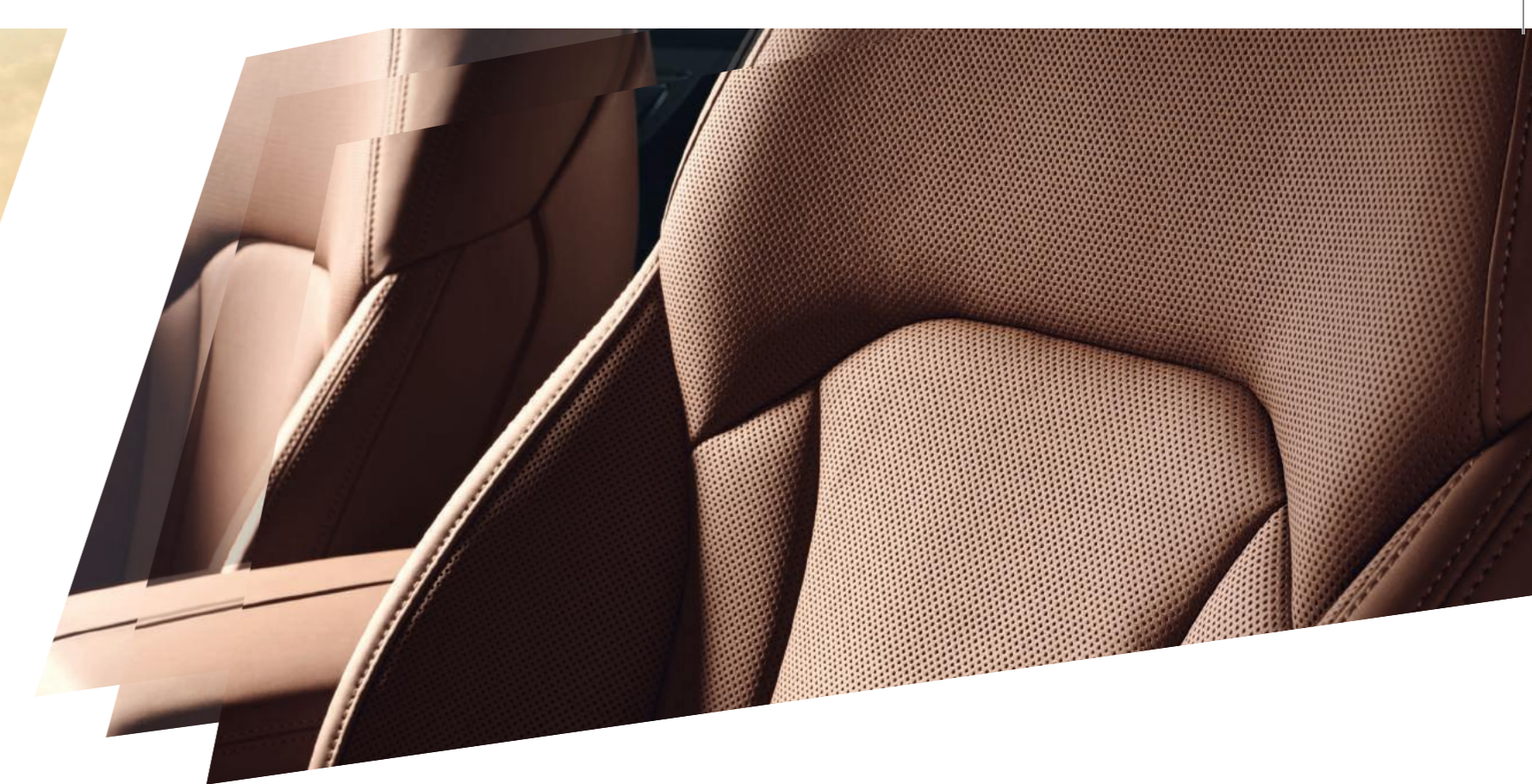

Comfort on a higher level.

The interior concept of the new Audi Q7: space to unleash your ideas. Take the seats, for example. Choose from a wide selection of high-quality materials, colours and functions.

Premium quality, excellent workmanship. Elegant atmosphere included. Double inlays for various customised application combinations. Just as you like it. You can also tailor the automatic air conditioning to your wishes. And, if you want, those of your passengers. Available with up to four individually adjustable climate zones.

Flexibility creates new space.

Space redefined. Or simply taken literally. Made possible by a seat and loading concept that concentrates solely on what's essential. You. With a generous feeling of space. And many different configuration options. For the right number of seats and amount of luggage at any given time. With a comfortable bench seat as a second row. Including separately adjustable seats for flexible volume in the luggage compartment. And a third row of seats on request. With two individual seats and electrically folded and raised backrests. Easy entry comes as standard. The new Audi Q7. With two, three, four, five, six or seven seats. And up to six child seats. Row upon row of good ideas for your flexibility.

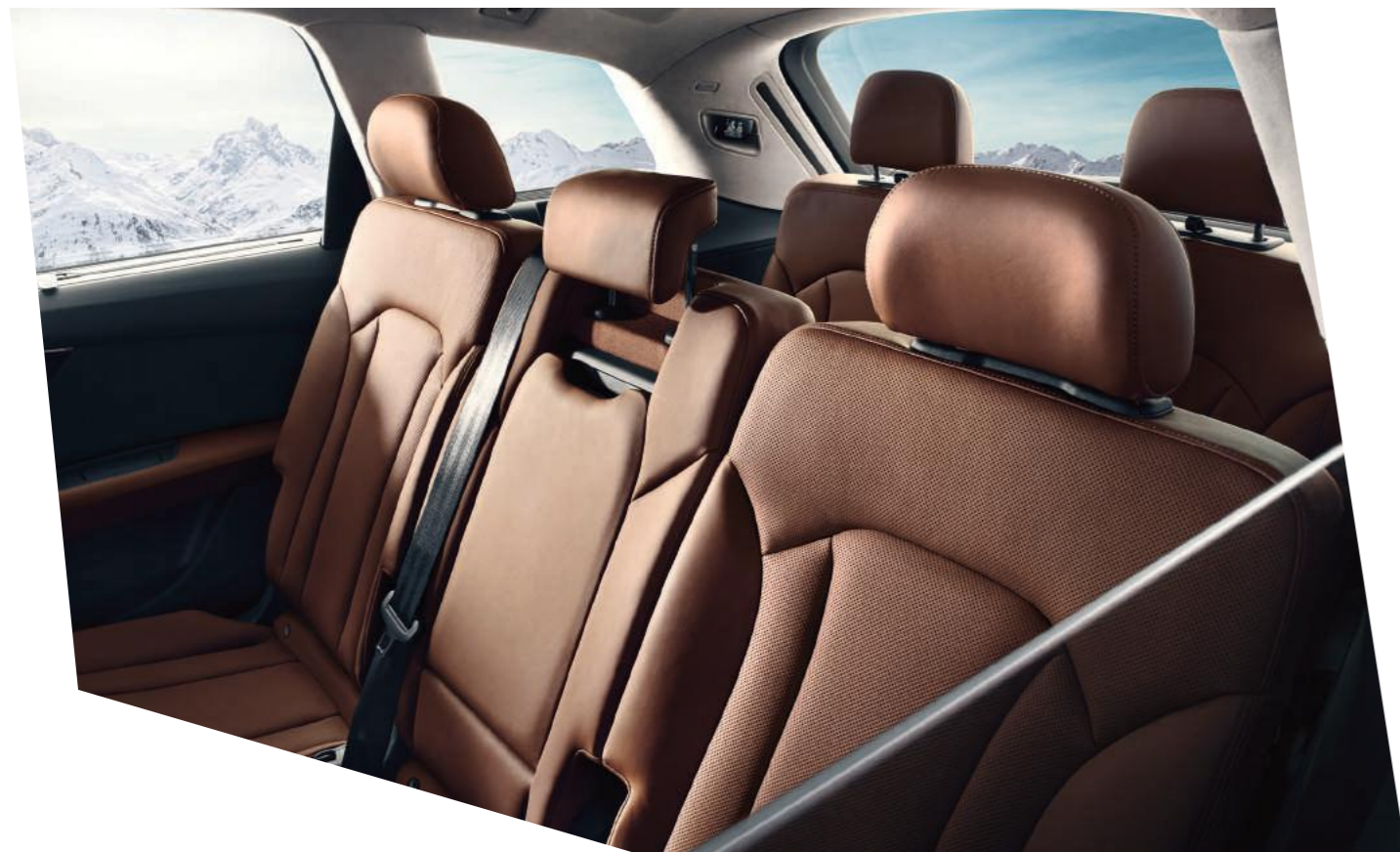

V  **r** **S**

Audi connect
Vorsprung connects.

quattro®
Vorsprung is superb.



Lighting technologies
Vorsprung is pioneering.

r **u** **n**

Audi ultra
Vorsprung is sustainable.

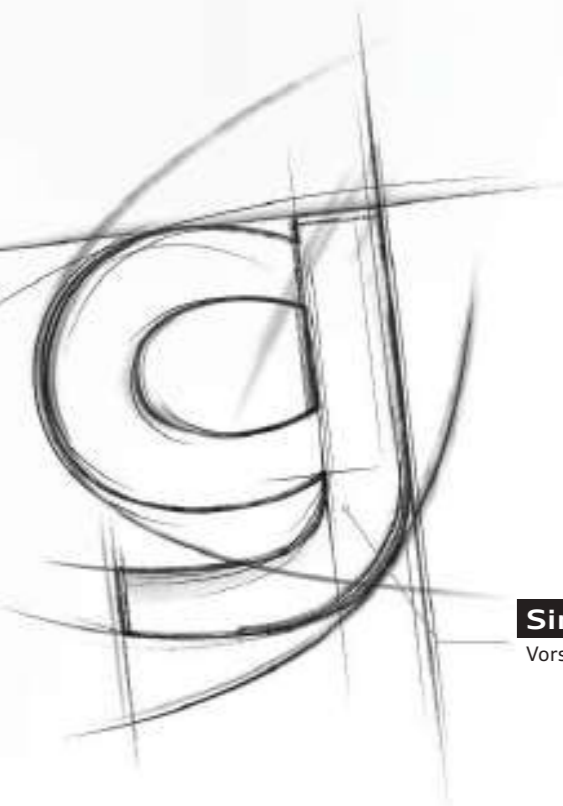

Simplicity
Vorsprung Simplifies.

... durch Technik.

The world is constantly changing. Technology is advancing at an ever faster pace. And in the process, more and more opportunities are opening up to you – nowhere more so than in the field of mobility. We are playing an instrumental role in shaping this progress with Vorsprung durch Technik. Striving to provide you with technology that enriches your life. Making sure that we don't just satisfy your expectations of mobility both today and in the future, but continue to surpass them.

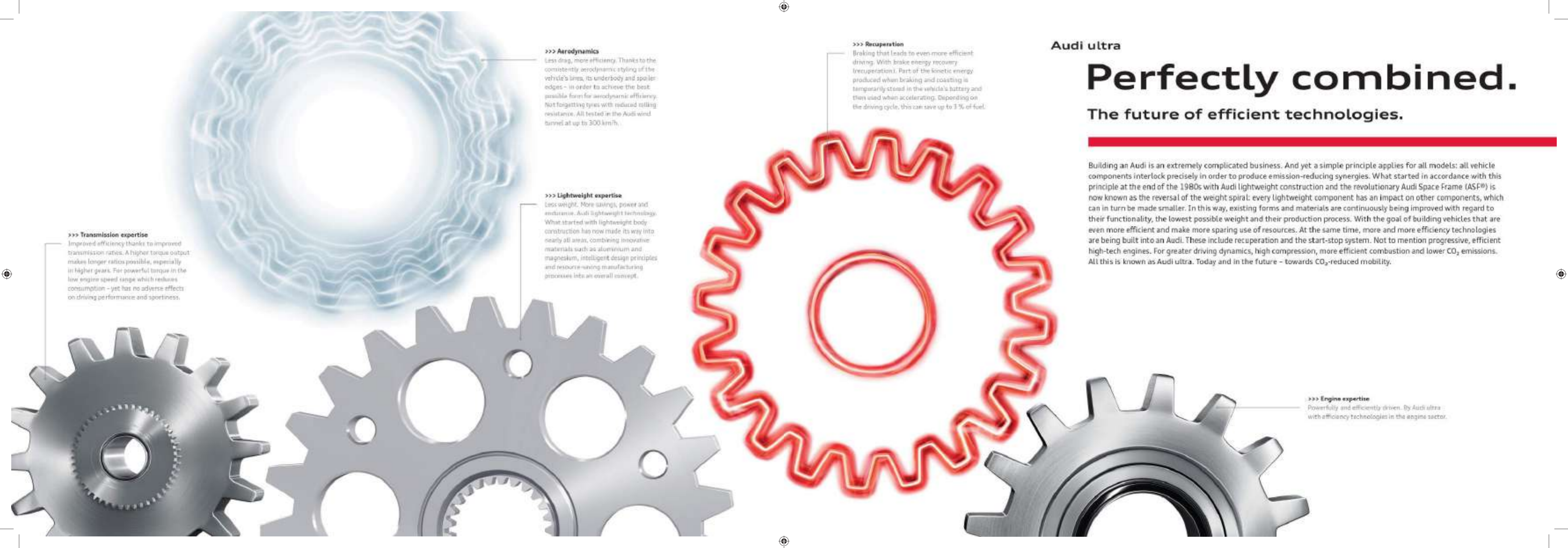

>>> Aerodynamics

Less drag, more efficiency. Thanks to the consistently aerodynamic styling of the vehicle's lines, its underbody and spoiler edges - in order to achieve the best possible form for aerodynamic efficiency. Not forgetting tyres with reduced rolling resistance. All tested in the Audi wind tunnel at up to 300 km/h.

>>> Lightweight expertise

Less weight. More savings, power and endurance. Audi lightweight technology. What started with lightweight body construction has now made its way into nearly all areas, combining innovative materials such as aluminium and magnesium, intelligent design principles and resource-saving manufacturing processes into an overall concept.

>>> Recuperation

Braking that leads to even more efficient driving. With brake energy recovery (recuperation). Part of the kinetic energy produced when braking and coasting is temporarily stored in the vehicle's battery and then used when accelerating. Depending on the driving cycle, this can save up to 3% of fuel.

>>> Transmission expertise

Improved efficiency thanks to improved transmission ratios. A higher torque output makes longer ratios possible, especially in higher gears. For powerful torque in the low engine speed range which reduces consumption - yet has no adverse effects on driving performance and sportiness.

>>> Engine expertise

Powerfully and efficiently driven. By Audi ultra with efficiency technologies in the engine sector.

Audi ultra

Perfectly combined.

The future of efficient technologies.

Building an Audi is an extremely complicated business. And yet a simple principle applies for all models: all vehicle components interlock precisely in order to produce emission-reducing synergies. What started in accordance with this principle at the end of the 1980s with Audi lightweight construction and the revolutionary Audi Space Frame (ASF®) is now known as the reversal of the weight spiral: every lightweight component has an impact on other components, which can in turn be made smaller. In this way, existing forms and materials are continuously being improved with regard to their functionality, the lowest possible weight and their production process. With the goal of building vehicles that are even more efficient and make more sparing use of resources. At the same time, more and more efficiency technologies are being built into an Audi. These include recuperation and the start-stop system. Not to mention progressive, efficient high-tech engines. For greater driving dynamics, high compression, more efficient combustion and lower CO₂ emissions. All this is known as Audi ultra. Today and in the future - towards CO₂-reduced mobility.

>>> tiptronic

8-speed automatic transmission with Dynamic Shift Program (DSP) and sport program; option of manual control via shift paddles on the multifunction leather steering wheel or by nudging the selector lever

>>> Audi drive select

Audi drive select lets you adjust the driving characteristics of your Audi to your preference, at the push of a button. Sportier, more comfortable, more balanced, more economical or even individually tailored as you please - it's entirely up to you.

>>> Electronic Stabilisation Control (ESC)

provides high stability and increased traction by means of situation-dependent intervention in the engine management system and the vehicle braking system. Adaptive ABS uses offroad detection to optimise the braking performance depending on the driving surface.

>>> quattro®

quattro permanent all-wheel drive with asymmetric/ dynamic torque distribution through a self-locking centre differential and wheel-selective torque control.

>>> Adaptive air suspension

automatically regulates the vehicle height and damping by means of the electronically controlled air suspension with infinitely variable adaptive damping system on all 4 wheels.

Dynamics

Dynamics

that will take hold of you.

Get in. Buckle up. Start the engine. Wherever you're heading, enthralling driving dynamics will power you there. For as you know, the world is your oyster once you get behind the wheel of your Audi. You decide the direction. The driving style. The pace. And you enjoy the satisfaction of knowing you have plenty in reserve. More than enough to get the very best from every drive.



>>> Hold assist
stops the vehicle over an indefinite period of time in uphill or downhill gradients usual in traffic. System is activated by push-button and allows driver to drive away smoothly.

>>> Hill descent control
aids the driver when travelling downhill to maintain the desired speed by exploiting the engine-drag torque and active brake interventions.

>>> Cruise control plus
at speeds from about 30 and above, the system keeps the set speed constant, provided that engine power and engine braking effect permit. The LIM button can be used to switch between the cruise control and the programmable speed limiter.

Assistance systems

Wherever you're heading, peace of mind will be your constant companion.

With the assistance systems in your Audi.

Each drive is different. Yet they all have one thing in common – the feeling of being protected that you get from every Audi. All driver assistance systems in your Audi help you during your journey and guarantee even greater comfort when you're on the road. Get to know the most important driver assistance systems.

>>> Audi park assist with 360 degree cameras
searches for suitable parking space along the road by means of ultrasonic sensors and 4 wide-angle 360 degree cameras that cover the entire area directly around the vehicle. Provides support when parking and leaving by means of independent steering action.

Please note: The systems work only within system limits and assist the driver. However, the driver remains responsible for driving the vehicle and is required to be attentive at all times.

your MMI



>>> Navigation

With MMI navigation plus with MMI touch you can let yourself be guided to your destinations with even greater ease by the 3D map view and 3-dimensional display of places of interest and landmark buildings.

>>> Car

Control and alter driver assistance systems, vehicle settings as well as climate control and service functions quickly and easily.

>>> Media

Display the covers of your music collection on all available media sources such as jukebox, inserted SD cards, Audi music interface, CDs or DVDs.



>>> Audi virtual cockpit

innovative, fully digital 12.3-inch instrument cluster for flexible display of information tailored to the drivers needs; the Audi virtual cockpit is operated via the multifunction steering wheel.

>>> Phone

Make phone calls safely and easily using the hands-free facility; simply select the number to dial from your contacts in the MMI or enter the number via the rotary dial.

Simplexity

The MMI® – intelligent, individual, intuitive.

Streamlined. Simple. Logical. The world of mobile infotainment completely redefined: the Multi Media Interface (MMI). Phoning, navigating or surfing the internet via Audi connect: all highly intuitive, highly functional and highly convenient - not least thanks to voice control. With the MMI in your new Audi, everything will be child's play for you.

Solid paint finishes

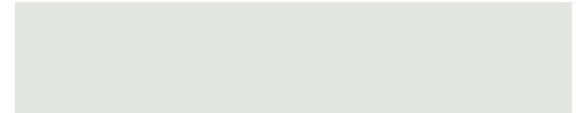

Carrara White



Deep black

Metallic paint finishes

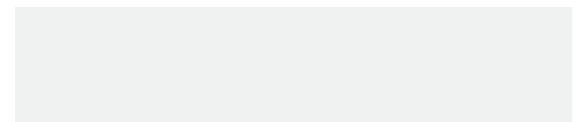

Glacier white, metallic



Argus brown, metallic



Orca black, metallic



Floret silver, metallic



Cobra beige, metallic



Samurai grey, metallic



Galaxy blue, metallic



Navarre blue, metallic

Model	Audi Q7 3.0 TFSI quattro tiptronic (7-seater)
Engine type	V6 petrol engine with direct fuel injection and mechanical supercharger
Displacement in cc (valves per cylinder)	2,995 (4)
Max. output in kW(bhp) at rpm	245 (333) / 5,500 – 6,500
Max. torque in Nm at rpm	440 / 2,900 – 5,300
Power transmission/wheels	
Drive type	quattro® permanent all-wheel drive
Transmission type	8-speed tiptronic transmission
Weights/capacities	
Unladen weight in kg	2,105
Gross vehicle weight	2,910
Permissible roof load limit	100
Fuel tank capacity	85
Performance/consumption	
Top speed in km/h	250
Acceleration 0-100km/h in s	6.3
Fuel grade	Sulphur-free super unleaded RON 95
Fuel consumption (combined) in l/100km	7.9
CO ₂ emissions (combined) in g/km	183
Emission standard	EU6

TFSI®

3.0-litre V6 TFSI engine in the Audi Q7 with FSI - petrol direct injection, supercharger (switchable) with two intercoolers, variable inlet and outlet camshaft timing and chain driven camshafts.

2,995cm³
245kW (333bhp) @ 5,500 - 6,500min⁻¹
440Nm @ 2,900 - 5,300min⁻¹



20" x 9J '5 spoke blade' design alloy wheels with 265/35 R20

Audi Q7 (7-seater)

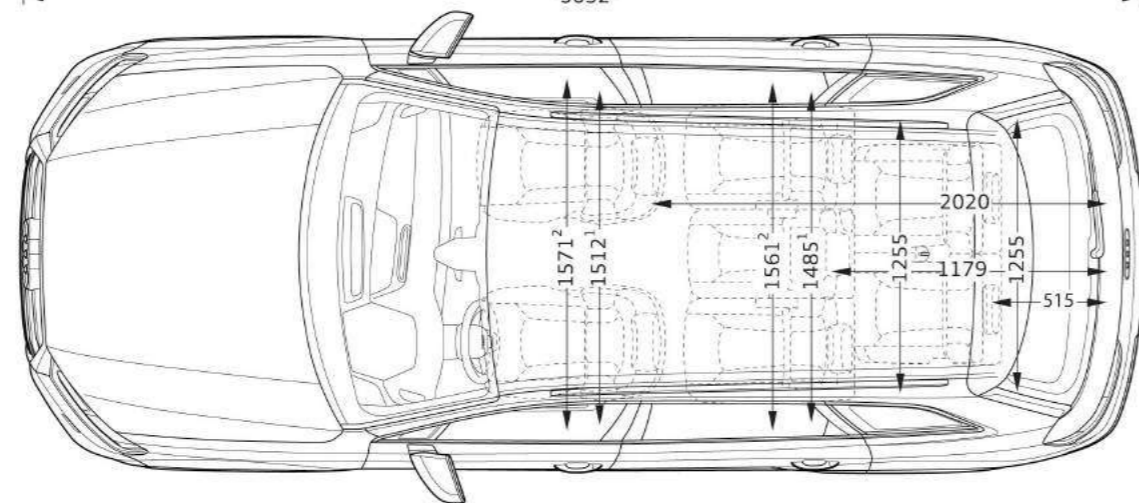
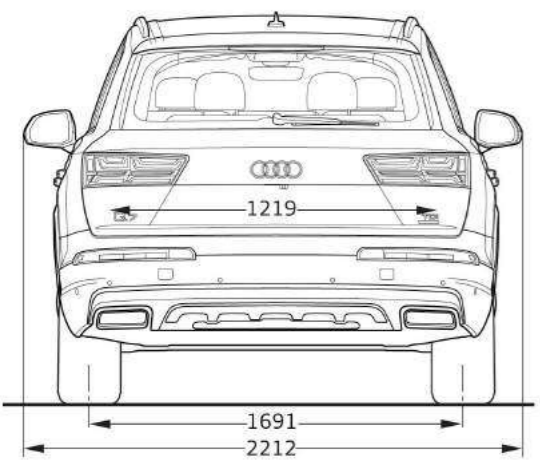
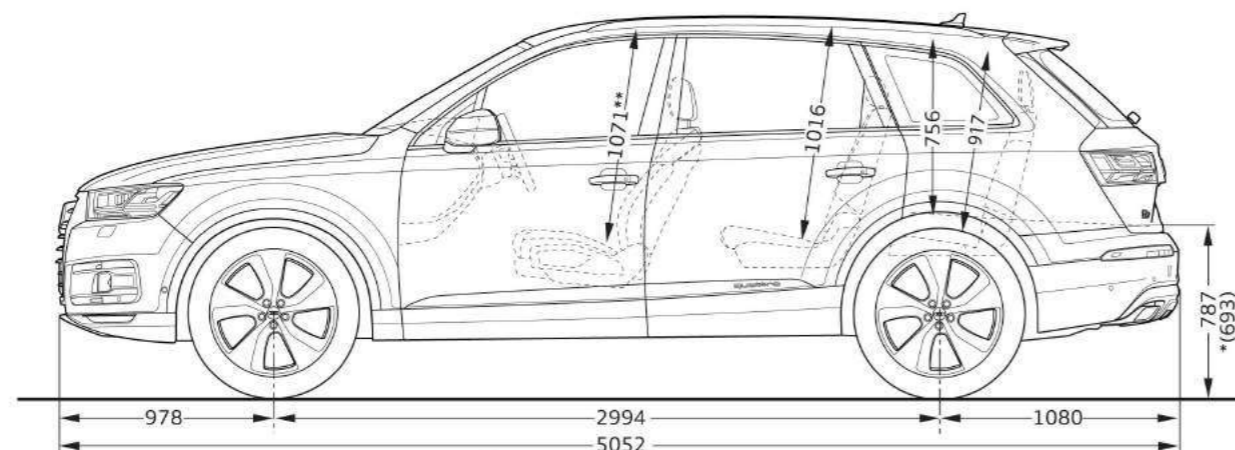
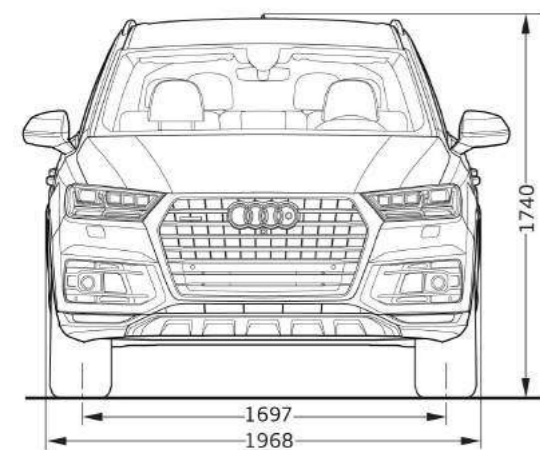

Dimensions in millimetres.
 Dimensions measured with vehicle at unladen weight.
 Luggage compartment volume in litres: 295/770/1,955 (2nd value: 3rd row seats folded)
 (measured by the VDA method using 200 x 100 x 50 mm blocks).
 Turning circle approx. 12.4 m.
 *Maximum headroom. ¹Elbow room width. ²Shoulder room width.



Audi Malaysia

A business division of Volkswagen Group Malaysia (“VGM”)
www.audi.com.my

Printed February 2019

The models and equipment versions illustrated and described in this brochure and some of the services listed are not available in all countries. Some of the cars illustrated are equipped with optional features for which an extra charge is made. Details concerning the delivery specifications, appearance, performance, dimensions and weights, fuel consumption and running costs of the vehicle were correct to the best of our knowledge at the time of going to press. Deviations from the colours and shapes shown in the illustrations may occur. No liability is accepted for errors and printing errors.